



EMC TEST REPORT

Applicant : Guangzhou Felicity Solar Technology Co., Ltd.
Address : (Airport Baiyun)No.2, 4, 6, 8, 10 and 12 Donghua Huaye Road, Renhe Town, Baiyun District, Guangzhou, Guangdong, P. R. China

Manufacturer : Guangzhou Felicity Solar Technology Co., Ltd.
Address : (Airport Baiyun)No.2, 4, 6, 8, 10 and 12 Donghua Huaye Road, Renhe Town, Baiyun District, Guangzhou, Guangdong, P. R. China

Factory : Guangzhou Felicity Solar Technology Co., Ltd.
Address : (Airport Baiyun)No.2, 4, 6, 8, 10 and 12 Donghua Huaye Road, Renhe Town, Baiyun District, Guangzhou, Guangdong, P. R. China

Product Name : Hybrid inverter

Brand Name :  Felicity solar®
Make life full of hope

Model No. : IVGM12KLP3G2, IVGM10KLP3G2, IVGM8KLP3G2, IVGM6KLP3G2, IVGM5KLP3G2, IVGM4KLP3G2, IVGM3KLP3G2

Standard : EN 62920:2017+ A11:2020+ A1:2021
IEC 62920:2017+A1:2021
EN IEC 61000-6-1:2019
EN IEC 61000-6-2:2019
EN IEC 61000-6-3:2021
EN IEC 61000-6-4:2019

Date of Receiving : January 10, 2026
Samples : April 26, 2026

Date of Test : January 16, 2026 to March 12, 2026
April 29, 2026 to May 15, 2026

Date of Report : May 20, 2026

This Test Report is Issued Under the Authority of:

Prepared by

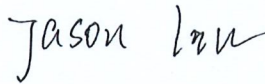

Jason Liu / Engineer

Approved & Authorized Signer



Han Song / Authorized Signatory

This report shows that above equipment is technically compliant with the requirements of the standards above. All test results in this report apply only to the tested sample(s). Without prior written approval of Shenzhen Nore Testing Center Co., Ltd, this report shall not be reproduced except in full.

TABLE OF CONTENTS

1. SUMMARY OF TEST RESULTS	5
2. TEST UNCERTAINTY	6
3. GENERAL INFORMATION	7
3.1. Product Information	7
3.2. Description of Support Device	9
3.3. Block Diagram of Test Setup	10
3.4. Test Mode	11
3.5. Test Conditions	12
3.6. Sample Calculations	13
3.7. Test Facility	14
3.8. Abnormalities from Standard Conditions	14
4. MEASURING DEVICES AND TEST EQUIPMENT	15
4.1. For Conducted Emission Measurement	15
4.2. For Radiated Emission Measurement	15
4.3. For Harmonic Current/ Flicker Measurement	15
4.4. For Electrostatic Discharge Test	15
4.5. For Radio-Frequency Electromagnetic Field Test	16
4.6. For Fast transients Test	16
4.7. For Surges Test	16
4.8. For Radio-Frequency Common Mode Test	17
4.9. For Power-Frequency Magnetic Field Test	17
4.10. For Voltage Dips and Interruption Test	17
5. CONDUCTED EMISSION MEASUREMENT	18
5.1. Block Diagram of Test Setup	18
5.2. Limit of Conducted Emission Measurement	18
5.3. Test Procedure	20
5.4. Test Results	20
6. RADIATED EMISSION MEASUREMENT	49
6.1. Block Diagram of Test Setup	49
6.2. Limit of Radiated Emission Measurement	49
6.3. Test Procedure	50
6.4. Test Results	50
7. HARMONIC CURRENT EMISSION MEASUREMENT	61
7.1. Block Diagram of Test Setup	61
7.2. Test Limits	61
7.3. Test Procedure	62
7.4. Test Results	62
8. VOLTAGE FLUCTUATIONS & FLICKER MEASUREMENT	69
8.1. Block Diagram of Test Setup	69
8.2. Test Limits	69
8.3. Test Procedure	69
8.4. Test Results	69
9. PERFORMANCE CRITERIA FOR IMMUNITY	72
10. ELECTROSTATIC DISCHARGE TEST	73
10.1. Block Diagram of Test Setup	73
10.2. Test Standard and Severity Levels	73
10.3. Test Procedure	74
10.4. Test Results	75
11. RADIO-FREQUENCY ELECTROMAGNETIC FIELD TEST	77
11.1. Block Diagram of Test Setup	77
11.2. Test Standard and Severity Levels	78
11.3. Test Procedure	78
11.4. Test Results	78
12. FAST TRANSIENTS TEST	80

12.1. Block Diagram of Test Setup	80
12.2. Test Standard and Severity Levels	81
12.3. Test Procedure	82
12.4. Test Results	82
13. SURGES TEST	84
13.1. Block Diagram of Test Setup	84
13.2. Test Standard and Severity Levels	84
13.3. Test Procedure	85
13.4. Test Results	85
14. RADIO-FREQUENCY COMMON MODE TEST	87
14.1. Block Diagram of Test Setup	87
14.2. Test Standard and Severity Levels	87
14.3. Test Procedure	88
14.4. Test Results	88
15. POWER-FREQUENCY MAGNETIC FIELD TEST	90
15.1. Block Diagram of Test Setup	90
15.2. Test Standard and Severity Levels	90
15.3. Test Procedure	91
15.4. Test Results	91
16. VOLTAGE DIPS AND INTERRUPTIONS TEST	93
16.1. Block Diagram of Test Setup	93
16.2. Test Standard and Severity Levels	93
16.3. Test Procedure	94
16.4. Test Results	94
APPENDIX I - PHOTOS OF TEST SET-UP	97
APPENDIX II - PHOTOS OF E.U.T	102

1.SUMMARY OF TEST RESULTS

The E.U.T. has been tested according to the following specifications:

EMISSION			
Standard	Test Type	Result	Remarks
EN 62920:2017+ A11:2020+ A1:2021 EN IEC 61000-6-3:2021 EN IEC 61000-6-4:2019	Conducted Emission Measurement	PASS	Meet the requirements of residential environment
	Radiated Emission Measurement	PASS	Meet the requirements of residential environment
IEC 61000-3-2:2014 IEC 61000-3-12:2011	Harmonic Current Emission Measurement	PASS	Meet the requirements
IEC 61000-3-3:2013 IEC 61000-3-11:2000	Voltage Fluctuations & Flicker Measurement	PASS	Meet the requirements

IMMUNITY (EN IEC 61000-6-1:2019/ EN IEC 61000-6-2:2019/ EN 62920:2017+ A11:2020+ A1:2021)			
Basic Standard	Test Type	Result	Results (Performance Criterion)
IEC 61000-4-2:2008	Electrostatic Discharge Test	PASS	A
IEC 61000-4-3:2006+ A1:2007+ A2:2010	Radio-Frequency Electromagnetic Field Test	PASS	A
IEC 61000-4-4:2012	Fast transients Test	PASS	A
IEC 61000-4-5:2014	Surges Test	PASS	A
IEC 61000-4-6:2013	Radio-Frequency Common Mode Test	PASS	A
IEC 61000-4-8:2009	Power-Frequency Magnetic Field Test	PASS	A
IEC 61000-4-11:2004 IEC 61000-4-34: 2005+A1:2009	Voltage Dips and Interruptions Test	PASS	B

2.TEST UNCERTAINTY

Where relevant, the following test uncertainty levels have been estimated for tests performed on the Product as specified in CISPR 16-4-2. This uncertainty represents an expanded uncertainty expressed at approximately the 95% confidence level using a coverage factor of $k=2$.

Test item	Uncertainty
Conducted Emission Measurement (0.15-30MHz)	$\pm 2.7\text{dB}$
Radiated Emission Measurement (30-1000MHz)	$\pm 4.4\text{dB}$

Note: As U_{lab} in all applicable tests listed above are less than U_{CISPR} according to CISPR 16-4-2, compliance is deemed to occur if no measured disturbance exceeds the disturbance limit; non-compliance is deemed to occur if any measured disturbance exceeds the disturbance limit.

3.GENERAL INFORMATION

3.1.Product Information

Product Name:	Hybrid inverter
Model No.:	IVGM12KLP3G2, IVGM10KLP3G2, IVGM8KLP3G2, IVGM6KLP3G2, IVGM5KLP3G2, IVGM4KLP3G2, IVGM3KLP3G2
Description of model difference:	1. These models have the same circuitry, PCB layout and physical construction, the difference is model name and the power changed by the software. 2. We tested all items at IVGM12KLP3G2 and only harmonic current, flicker, voltage dips and interruption were tested at IVGM10KLP3G2.
Classification of Equipment:	Such equipment would fulfill the tighter emission requirements of the residential environment as well as the severe immunity requirements of the industrial environment.
Typical arrangement:	Tabletop or/and Wall-Mounted
Highest Internal Frequency:	Below 108MHz (Highest internal frequency below 108MHz, radiation test frequency range 30MHz-1000MHz)
Rating:	<p>Model: IVGM12KLP3G2 Product Type: Hybrid Inverter Overvoltage-category: DC II; AC III Ambient Temperture: -40°C~60°C, >45°C Derating</p> <p>Battery Battery Voltage Range: 40Vd.c.-60Vd.c. Max. Charging and Discharging Current: 240Ad.c./240Ad.c.</p> <p>PV PV Input Voltage: 550Vd.c.(160Vd.c.-800Vd.c.) MPPT Input Range: 200Vd.c.~650Vd.c. Max. Input Current: 26Ad.c./26Ad.c. Max. Shorted Current: 39Ad.c./39Ad.c. Max. PV Input Power: 18000W</p> <p>On-Grid Mode AC Input/Output Voltage: 3L/N/PE 220/380Va.c., 230/400Va.c. AC Input/Output Frequency: 50/60Hz AC Input/Output Rated Current: 18.3/17.4Aa.c. Max. AC Input/Output Current: 20/19.1Aa.c. Max. Continuous AC Passthrough: 45Aa.c. AC Input/Output Rated Active Power: 12000W AC Input/Output Apparent Power: 13200VA AC Input/Output Power Factor: 0.8 Leading To 0.8 Lagging</p>

	<p>Off-Grid Mode AC Output Voltage: 3L/N/PE 220/380Va.c., 230/400Va.c. AC Output Frequency: 50/60Hz Max. AC Output Current: 20/19.1Aa.c. Max.AC Output Apparent Power: 13200VA Non-isolated topology, IP65, Class I protective class</p> <p>Model: IVGM10KLP3G2 Product Type: Hybrid Inverter Overvoltage-category: DC II; AC III Ambient Temperture: -40°C~60°C, >45°C Derating</p> <p>Battery Battery Voltage Range: 40Vd.c.-60Vd.c. Max. Charging and Discharging Current: 210Ad.c./210Ad.c.</p> <p>PV PV Input Voltage: 550Vd.c.(160Vd.c.-800Vd.c.) MPPT Input Range: 200Vd.c.~650Vd.c. Max. Input Current: 26Ad.c./26Ad.c. Max. Shorted Current: 39Ad.c./39Ad.c. Max. PV Input Power: 15000W</p> <p>On-Grid Mode AC Input/Output Voltage: 3L/N/PE 220/380Va.c., 230/400Va.c. AC Input/Output Frequency: 50/60Hz AC Input/Output Rated Current: 15.1/14.5Aa.c. Max. AC Input/Output Current: 16.7/15.9Aa.c. Max. Continuous AC Passthrough: 45Aa.c. AC Input/Output Rated Active Power: 10000W AC Input/Output Apparent Power: 11000VA AC Input/Output Power Factor: 0.8 Leading To 0.8 Lagging</p> <p>Off-Grid Mode AC Output Voltage: 3L/N/PE 220/380Va.c., 230/400Va.c. AC Output Frequency: 50/60Hz Max. AC Output Current: 16.7/15.9Aa.c. Max.AC Output Apparent Power: 11000VA Non-isolated topology, IP65, Class I protective class</p>
Sample No.:	SZNTC2601039EV00-001 KA26021001EV00-001
Remark:	All the information above is provided by the manufacturer. For more detailed features of the EUT, please refer to the user manual.

3.2.Description of Support Device

No.	Equipment	Manufacturer	M/N	Cable Specification	Remark
1.	Lead acid battery	VISION GROUP	G12V 200AH *4	---	Provided by the lab.
2.	Incandescent lamp load	----	---	----	---
3.	Photovoltaic simulator source	ITECH	IT 6018C-1500-40	---	Provided by the lab.
4.	AC input cable	---	---	The test uses a power cable of 1.0m length without magnetic ring and unshielded.	Provided by the lab.
5.	AC output cable	---	---	The test uses a power cable of 1.0m length without magnetic ring and unshielded.	Provided by the lab.
6.	Battery cable	---	---	The test uses a power cable of 2.0m length without magnetic ring and unshielded.	Provided by the manufacturer
7.	PV cable	---	---	The test uses a power cable of 2.0m length without magnetic ring and unshielded.	Provided by the lab.

3.3. Block Diagram of Test Setup

Mode 1: Standby Mode

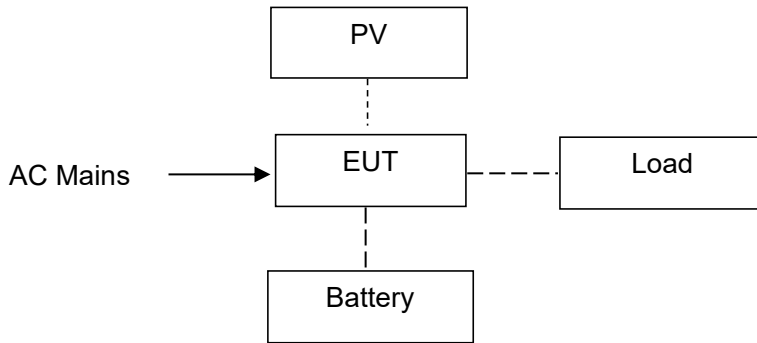

Mode 2: AC Charger Mode (AC Input+ Battery+ Load)

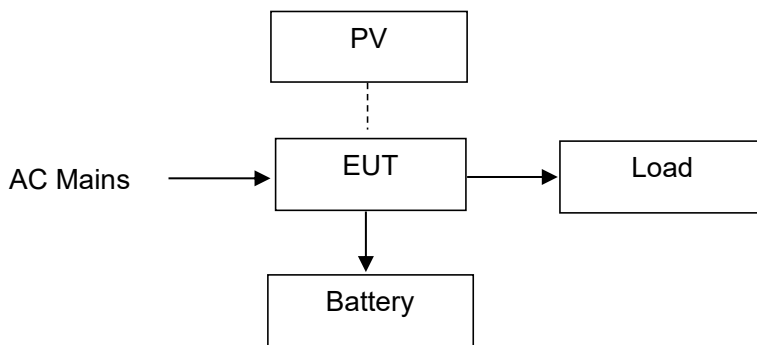

Mode 3: Solar Charger Mode (PV+ Battery+ Load)

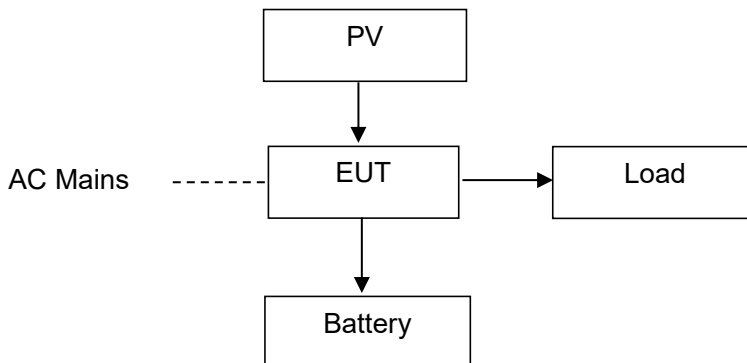

Mode 4: Grid Mode (Grid+ PV+ Battery+ Load)

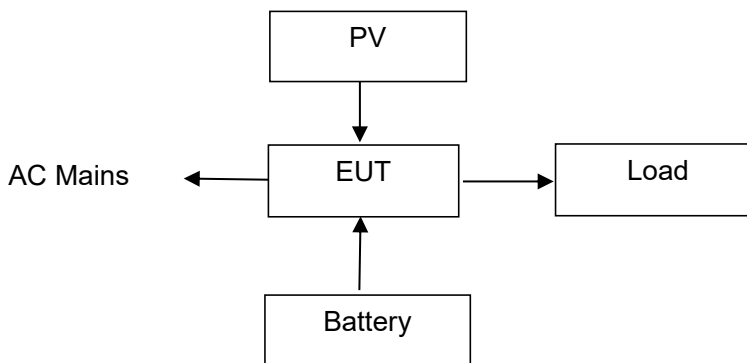

Mode 5: Inverter Mode (Battery+ Load)

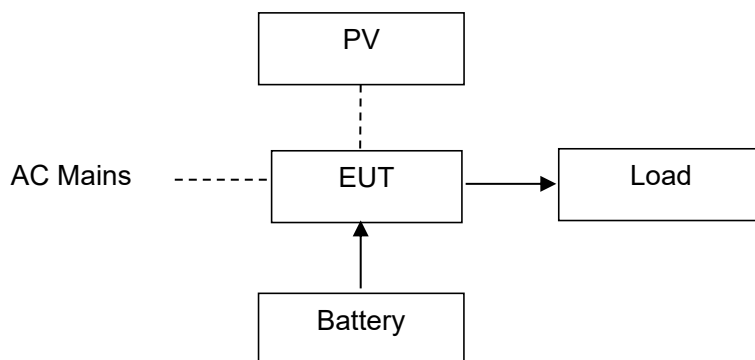

Remark: The dashed line indicates a power-off connection.

3.4. Test Mode

No.	Test Mode	Remark
1.	Standby Mode	The PCE is connected to the AC mains and is energized but does not generate or feed power into the AC mains or electrical energy storage devices. The voltage level at the DC power ports need not to be within the rated operation range.
2.	AC Charger Mode (AC Input + Battery+ Load)	The mains input charges the battery, and the AC output connects to an analog load.
3.	Solar Charger Mode (PV+ Battery+ Load)	The PV input charges the battery, and the AC output connects to an analog load.
4.	Grid Mode (Grid+ PV+ Battery+ Load)	PV and/or the battery are fed into the AC grid, and the AC output is connected to the analog load.
5.	Inverter Mode (Battery+ Load)	Battery inverter status, AC output connected to analog load.