

# USER MANUAL

## Off-Grid Solar Inverter IVDM4224P1G3



# Contents

<b>1. Safety Introductions</b> .....	1
<b>2.Product Introductions</b> .....	2
2.1 Product Overview.....	3
2.2 Product Dimensions.....	4
2.3 Product Features.....	5
2.4 Basic System Architecture.....	5
<b>3. Installation</b> .....	6
3.1 Parts List.....	6
3.2 Product handling requirements.....	7
3.3 Mounting instructions.....	7
3.4 Battery connection.....	11
3.5 Grid connection and backup load connection.....	12
3.6 PV Connection.....	14
3.6.1 PV Module Selection:.....	15
3.6.2 PV Module Wire Connection:.....	15
3.7 Earth Connection(mandatory).....	17
3.8 WIFI Connection.....	17
3.9 Wiring System for Inverter.....	18
<b>4.Operation</b> .....	19
4.1 Power ON/OFF.....	19
4.2 Operation and Display Panel.....	19
<b>5.LCD Display Icons</b> .....	20
5.1 Boot Screen.....	20
5.2 Main Screen.....	20
5.2.1 Power-on Instructions.....	22
5.2.2 LCD operation flow chart.....	23
5.2.3 Setup Wizard Steps.....	24

5.3 Solar Power Curve.....25

5.4 Setting Menu..... 27

    5.4.1 Setup Wizard..... 36

**6. Mode.....38**

**7.Fault Information and Processing..... 39**

    7.1 Preparations for Installation..... 39

    7.2 Warning Code.....40

    7.3 Fault Code..... 41

**8.Limitation of Liability..... 43**

**9.Datasheet..... 44**

**10.Appendix I..... 46**

**11.The Wi-Fi operation Guide in APP..... 47**

    11.1 Introduction..... 47

    11.2 Download and install APP..... 47

## **Revision History**

Revision No.	Revision Date	Revision Reason
1.0	2026.2	First Published

## About This Manual









This manual mainly describes product information, installation, operation, and maintenance guidelines. It does not cover all aspects of the photovoltaic (PV) system.

## How to Use This Manual

Read this manual and all related documents carefully before operating the inverter. Keep all documents properly stored and readily available for reference.

Contents may be periodically updated or revised due to product development. The information in this manual is subject to change without notice. The latest manual can be acquired via <https://www.felicitysolar.com/>

## 1. Safety Introductions

Symbols	Name	Instruction
	Danger	Serious injury or death may occur if the relevant safety requirements are not followed.
	Warning	Physical injury or equipment damage may occur if the relevant requirements are not followed.
	Electrostatic sensitive	Damage may occur if the relevant anti-static requirements are not followed.
	Hot surface	Sides of the device may become hot. Do not touch.
	Earth terminal	The inverter must be reliably grounded.
	Caution	Ensure that both DC and AC circuit breakers are disconnected, and wait at least 5 minutes before wiring or inspection.
<b>NOTE</b>	Note	The procedures taken for ensuring proper operation.
	CE mark	The inverter complies with the CE directive.
	EU WEEE mark	Product should not be disposed as household waste.

- This chapter provides important safety and operating instructions. Read and retain this manual for future reference.
- Before using the inverter, please read the battery instructions, warning signs, and related sections of this manual.
- Do not disassemble the inverter. For maintenance or repair, contact a qualified service center.
- Improper reassembly may cause electric shock or fire.
- To reduce the risk of electric shock, disconnect all wires before performing any maintenance or cleaning. Turning off the unit alone will not eliminate this risk.
- Caution: Only qualified personnel should install this device with a battery.
- Never charge a frozen battery.
- For optimal operation, follow the required specifications to select the correct cable size. Proper installation is essential for reliable performance.
- Be cautious when working with metal tools around batteries. Dropping a tool may cause sparks, short circuits, or even explosions.
- Please strictly follow installation procedure when you want to disconnect AC or DC terminals.
- Please refer to "Installation" section of this manual for the details.
- Grounding instructions – this inverter must be connected to a permanently grounded wiring system. Ensure compliance with local requirements and regulations during installation.
- Never short-circuit the AC output or DC input. Do not connect the inverter to the mains if the DC input is short-circuited.

## **2. Product Introductions**

This multi-functional inverter integrates an inverter, solar charger, and battery charger, providing uninterruptible power supply in a compact design. The LCD display allows users to configure and operate key functions easily, including battery charging, AC/solar charging, and input voltage settings for various applications.

## 2.1 Product Overview

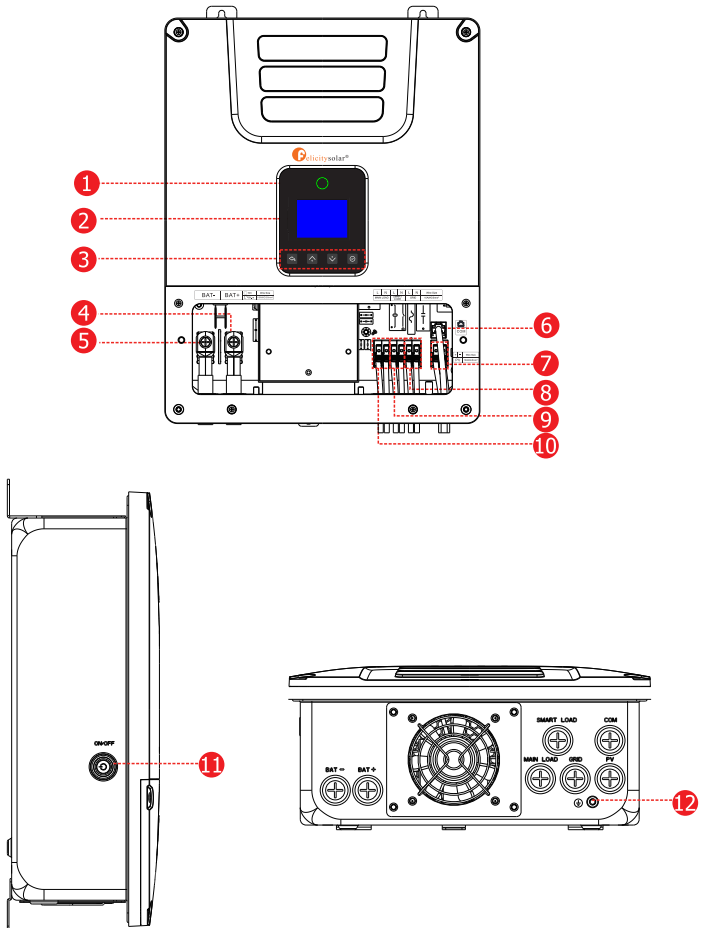

- 1. Inverter indicator
- 2. LCD Display
- 3. Function buttons
- 4. BAT+
- 5. BAT-
- 6. Communication port

- 7. PV input connection port
- 8. Grid port
- 9. Smart Load port
- 10. Main Load port
- 11. Power ON/OFF button
- 12. PE

## 2.2 Product Dimensions

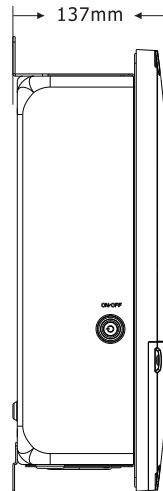
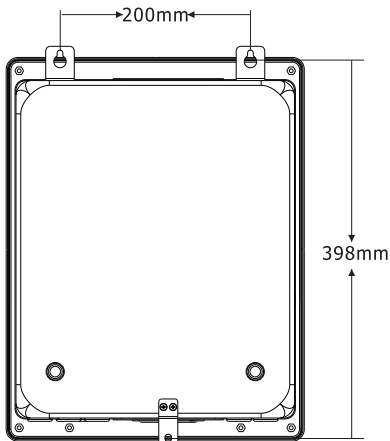
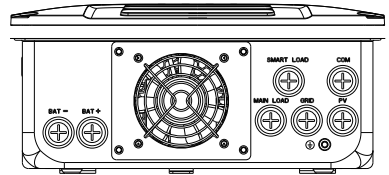
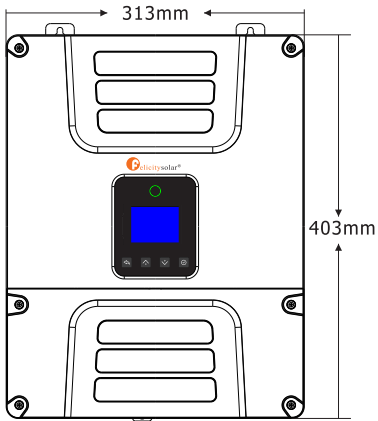

### 2.3 Product Features

- Supports self-consumption operation.
- Auto restart while AC is recovering.
- Programmable multiple operation modes: on-grid, off-grid, and UPS.
- Configurable battery charging current via LCD settings based on application needs.
- Compatible with grid power sources.
- Overload, over-temperature, and short-circuit protection.
- Built-in limit function to prevent excess power from feeding back to the grid.
- Supports remote monitoring and built-in MPPT tracker.

### 2.4 Basic System Architecture



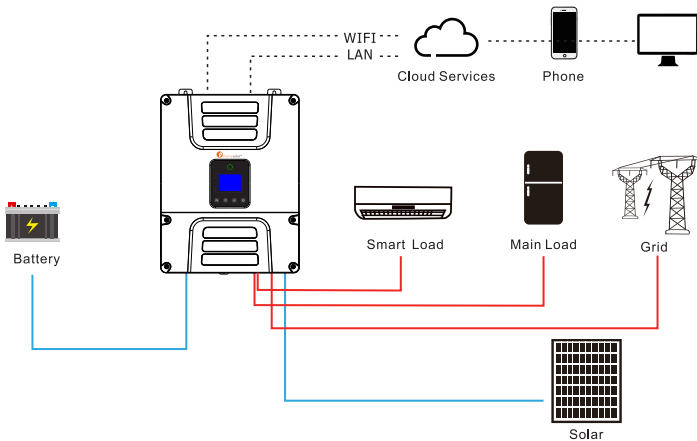



- The following illustration shows the basic application of this inverter.
- It also includes the following devices for a complete operating system.
- Utility
- PV modules
- Consult your system integrator for alternative system configurations based on specific requirements.
- This inverter can supply power to various home or office appliances, including motor-type devices such as refrigerators and air conditioners.

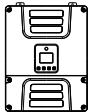

### 3. Installation

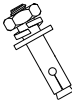
#### 3.1 Parts List

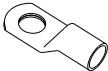
Check all equipment before installation to ensure there is no damage during transportation. The following items should be included in the package:

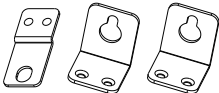
 Inverter × 1	 User Manual × 1	 Warranty Card × 1
 Expansion Screws × 3	 OT Terminals × 1	 SC-shaped Terminals × 2
 M4 Screws × 6	 Wall Mount Bracket × 3	

No.	Name	Description	Quantity
1	Inverter	Inverter	1
2	User Manual	User manual	1
3	Warranty Card	Warranty card	1
4	Expansion Screws	Used to secure the product's wall mount	3
5	OT terminals	Used for external grounding connection.	1
6	SC-shaped Terminals	Used for battery connection.	2
7	M4 Screws	For securing the product to the wall.	6
8	Wall Mount Bracket	For securing the product to the wall.	3

### 3.2 Product handling requirements

Lift the inverter out of the packing box and transport it to the designated installation location.

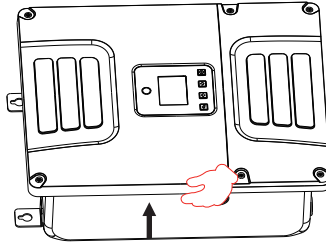

#### CAUTION:

- Improper handling may cause personal injury!
- Arrange an appropriate number of personnel to carry the inverter according to its weight. Installation personnel should wear protective equipment such as safety gloves and protective boots.
- Placing the inverter directly on a hard surface may damage its metal enclosure. Protective materials such as sponge pads or foam cushions should be placed underneath.
- Move the inverter by one or two persons, or use an appropriate transport tool.
- Lift the inverter using the provided handles.
- Keep the battery away from water and fire.

### 3.3 Mounting instructions

#### Installation Precaution

This inverter is designed for outdoor use (IP6X). Please ensure the installation site meets the following conditions:





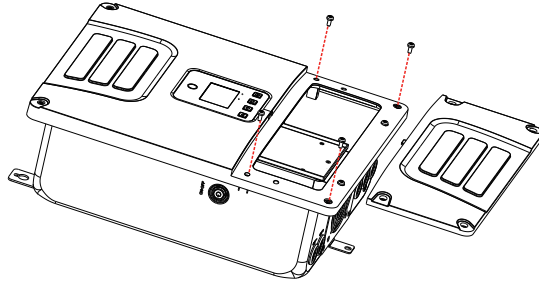

















- Avoid direct sunlight.
- Avoid areas where highly flammable materials are stored.
- Avoid potentially explosive areas.
- Avoid direct exposure to cold air.
- Do not install near television antennas or antenna cables.
- Do not install at altitudes exceeding approximately 3000 meters above sea level.
- Avoid environments with precipitation or humidity levels above 95%.

Avoid direct sunlight, rain exposure, or snow accumulation during installation and operation. Before connecting the wires, remove the wiring cover by unscrewing the screws as shown below. After wiring, reattach the small cover and tighten the screws to a torque of 1.2 N·m.



### Installation Tools

Refer to the following recommended installation tools. Other auxiliary tools may also be used as needed.

 Safety Gloves	 Heat Gun	 Safety Goggles	 Anti-dust Respirator	 Safety Shoes
 Marking Pen	 Level	 Screwdriver	 Hammer	 Anti-static Wrist Strap
 Cleaner	 Utility Knife	 Lineman Pliers	 Wire Cutter	 Wire Stripper
 Crimping Tool 4-6mm <sup>2</sup>	 Hydraulic Pliers	 RJ45 Crimping Plier	 Measuring Tape	 Percussion Drill
 Multimeter	 Socket Wrench Set			

**Considering the following points before selecting where to install:**

- Select a vertical wall with sufficient load-bearing capacity, preferably made of concrete or other non-flammable material. The installation example is shown below.
- Install this inverter at eye level in order to allow the LCD display to be read at all times.
- The ambient temperature is recommended to be between  $-40\sim 60^{\circ}\text{C}$  to ensure optimal operation.
- Be sure to keep other objects and surfaces as shown in the diagram to guarantee sufficient heat dissipation and have enough space for removing wires on site.

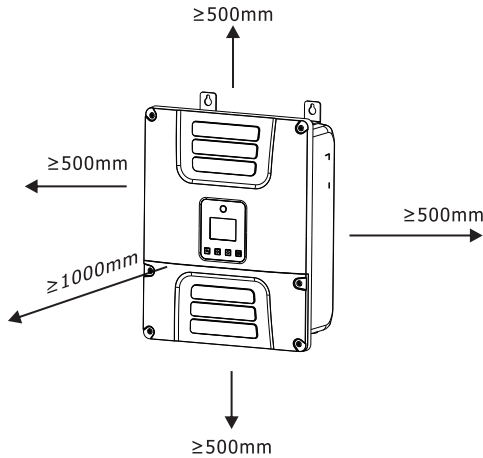

For proper air circulation to dissipate heat, allow a clearance of approx. 50cm to the side and approx. 50cm above and below the unit. And 100cm to the front.

### Mounting the inverter

This inverter is heavy. Use caution when unpacking or moving it.

1. Use a marker to mark the required drilling positions through the hinge openings.
2. Using an 8mm drill bit, drill 4 holes at the marked positions, each to a depth of 40mm.
3. Use an appropriate hammer to drive the expansion bolts into the holes, then unscrew the nuts from the bolts.
4. Lift and maneuver the inverter to align its hinge holes with the expansion bolts. Tighten the nuts securely to complete the installation.

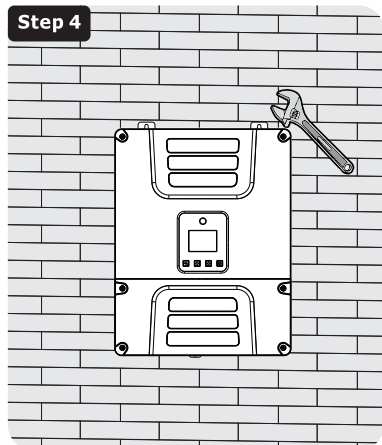
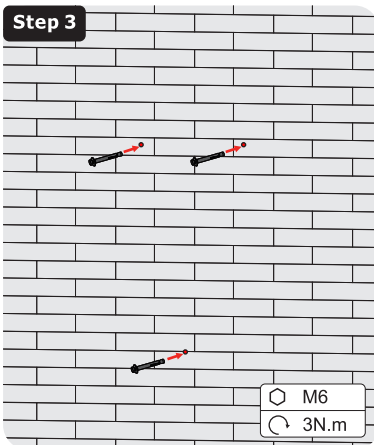
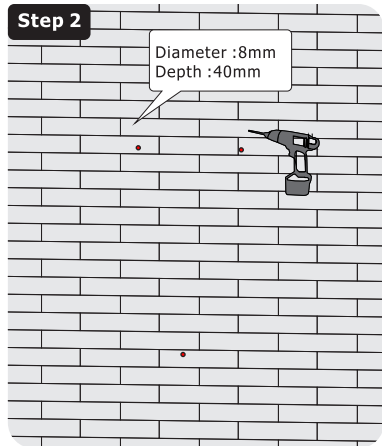
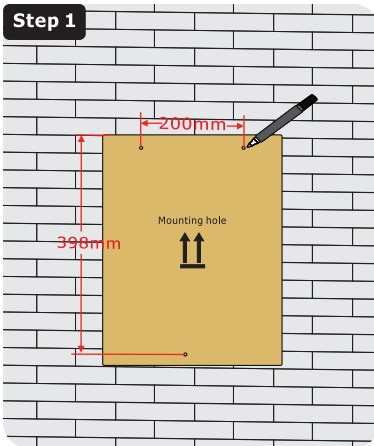

### 3.4 Battery connection

For safe operation and compliance, a separate DC over-current protector or disconnect device is required between the battery and the inverter. In some applications, switching devices may not be required but over-current protectors are still required. Refer to the typical amperage in the table below for the required fuse or circuit breaker size.

Model	Wire Size	Cable(mm <sup>2</sup> )
4.2kw	0AWG	50



All wiring must be performed by a professional person.  
 Connecting the battery with a suitable cable is important for safe and efficient operation of the system.

Please follow below steps to implement battery connection:

1. Please choose a suitable battery cable with correct connector which can well fit into the battery terminals.
2. Use a suitable screwdriver to unscrew the bolts and fit the battery connectors in, then fasten the bolt by the screwdriver, make sure the bolts are tightened with torque of 8N.m in clockwise direction.
3. Make sure polarity at both the battery and inverter is correctly connected.
4. To prevent access by children or entry of insects, fasten the inverter's connector to the waterproof position by twisting it clockwise.

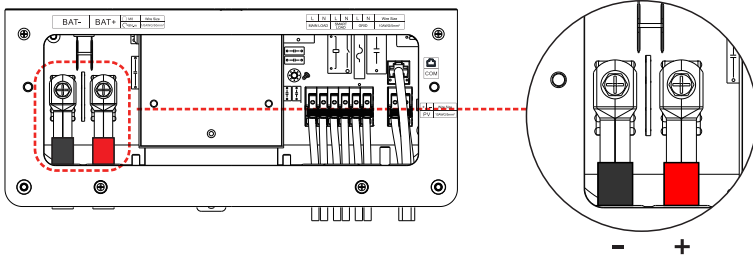

- Installation must be performed with care.
- Before making the final DC connection or closing the DC breaker/disconnector, ensure the positive (+) terminal is connected to positive (+) and the negative (-) terminal is connected to negative (-). Reversed battery polarity will damage the inverter.

### 3.5 Grid connection and backup load connection

- Before connecting to the grid, a separate AC breaker must be installed between the inverter and the grid, and also install a breaker between the backup load and the inverter. This will ensure the inverter can be securely disconnected during maintenance and fully protected from over current. For the 4.2kW model, the recommended AC breaker for backup load is 40A. For the 4.2kW model, the recommended AC breaker for grid is 40A.
- There are three terminal blocks labeled "GRID" and "LOAD". Do not connect input and output terminals incorrectly.



**Note:**

- In final installation, breaker certified according to IEC 60947-1 and IEC 60947-2 shall be installed with the equipment.
- All wiring must be performed by a qualified personnel. It is very important for system safety and efficient operation to use appropriate cable for AC input connection. To reduce risk of injury, please use the proper recommended cable as below.

Grid connection and backup load connection (Copper wires)

Model	Wire Size	Cable(mm <sup>2</sup> )
4.2kw	10AWG	5

Grid connection and backup load connection (Copper wires) (Bypass)

Model	Wire Size	Cable(mm <sup>2</sup> )
4.2kw	10AWG	5

**Please follow below steps to implement AC input/output connection:**

1. Before making Grid and Load port connection, be sure to turn off AC breaker or disconnecter first.
2. Connect the ground wire of Grid and Load first, followed by the neutral wire and the live wire.
3. Use wire cutters to cut open the wire sheath by about 10mm, use a tool to cut through the cut wire along this cross-shaped groove, lift the terminal clip, insert the wire and press the clip to fix it.

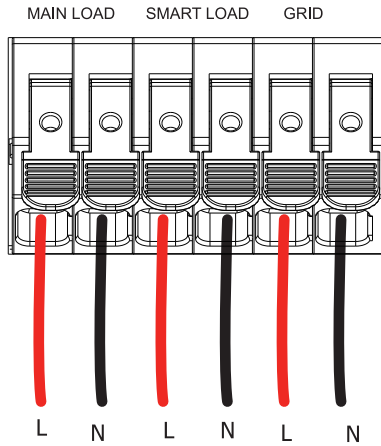
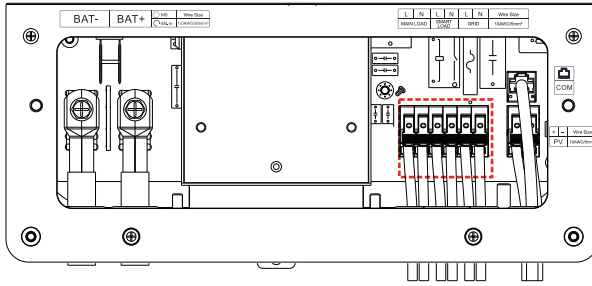



Ensure the AC power source is powered off before wiring the unit.

3. Then, insert AC output wires according to polarities indicated on the terminal block and tighten terminal. Be sure to connect corresponding N wires and PE wires to related terminals as well.

4. Make sure the wires are securely connected.

5. Appliances such as air conditioner are required at least 2-3 minutes to restart because it is required to have enough time to balance refrigerant gas inside of circuit. If a power shortage occurs and recovers in short time, it will cause damage to your connected appliances. To prevent this kind of damage, please check manufacturer of air conditioner if it is equipped with time-delay function before installation. Otherwise, this inverter will trigger overload fault and cut off output to protect your appliance but sometimes it still causes internal damage to the air conditioner.

### 3.6 PV Connection

Before connecting PV modules, install a separate DC circuit breaker between the inverter and the PV modules. It is very important for system safety and efficient operation to use appropriate cable for PV module connection. To reduce the risk of injury, use the recommended cable size shown below.

Model	Wire Size	Cable(mm <sup>2</sup> )
4.2kw	10AWG	5



To prevent malfunction, do not connect PV modules with potential current leakage to the inverter. For example, grounded PV modules will cause current leakage to the inverter. When using PV modules, please ensure the PV+ & PV- of solar panel is not connected to the system ground bar.



A PV junction box with surge protection must be used; otherwise, lightning strikes on PV modules may damage the inverter.

### 3.6.1 PV Module Selection:

When selecting proper PV modules, please be sure to consider below parameters:

- 1) Open circuit Voltage (Voc) of PV modules not exceeds the Max. PV input voltage of the table of inverter.
- 2) Open circuit Voltage (Voc) of PV modules should be higher than Start-up Voltage of the table.
- 3) The PV modules used to connected to this inverter shall be Class A rating certified according to IEC 61730.

Inverter Model	4.2kw
PV Input Voltage	350V(60V~500V)
MPPT Voltage Range	60V~425V
No. of MPP Trackers	1

### 3.6.2 PV Module Wire Connection:

1. Switch the Grid Supply Main Switch(AC)OFF.
2. Switch the DC Isolator OFF.
3. Assemble PV input connector to the inverter.



**Safety Hint:**

- Before connection, please make sure the polarity of the output voltage of PV array matches the "DC+" and "DC-" symbols.
- Before connecting inverter, please make sure the PV array's open circuit voltage less than 500V.



**Safety Hint:**

- Please use approved DC cable for PV system.voltage is within the 500V of the inverter.

The steps to assemble the DC connectors are listed as follows:

Step 1: Use wire cutters to cut open the wire sheath by about 10mm

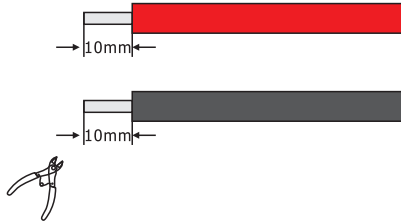

Step 2: Use a tool to cut through the cut wire along this cross-shaped groove, lift the terminal clip, insert the wire and press the clip to fix it.

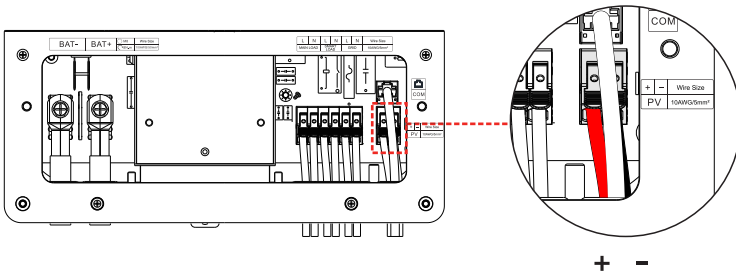

**Warning:**

Sunlight shines on the panel will generate voltage, high voltage in series may cause danger to life. Therefore, before connecting the DC input line, the solar panel needs to be blocked by the opaque material and the DC switch should be 'OFF', otherwise, the high voltage of the inverter may lead to life threatening conditions.

### 3.7 Earth Connection(mandatory)

Ground cable shall be connected to ground plate on grid side, this prevents electric shock if the original protective conductor fails.

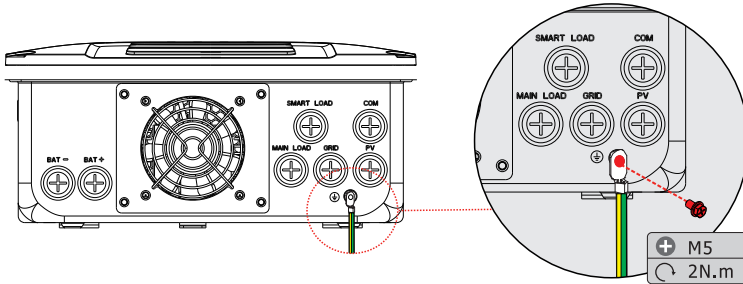

Earth connection (Copper wires)

Model	Wire Size	Cable(mm <sup>2</sup> )	Torque value(max)
4.2kW	8AWG	6.0	2.0Nm

Earth connection (Copper wires) (Bypass)

Model	Wire Size	Cable(mm <sup>2</sup> )	Torque value(max)
4.2kW	8AWG	6.0	2.0Nm



**Warning:**

Inverter has built-in leakage current detection circuit, The type A RCD can be connected to the inverter for protection according to the local laws and regulations.

If an external leakage current protection device is connected, its operating current must be equal to 300 mA or higher, otherwise inverter may not work properly.

### 3.8 WIFI Connection

The inverter integrated internal Wi-Fi module. Please refer to the APP manual for detail configurations.

### 3.9 Wiring System for Inverter

This diagram is an example for grid systems without special requirements on electrical wiring connection.

Note: The load PE line and earthing bar must be grounded properly and effectively.

Otherwise the back-up function may be abnormal when the grid fails.

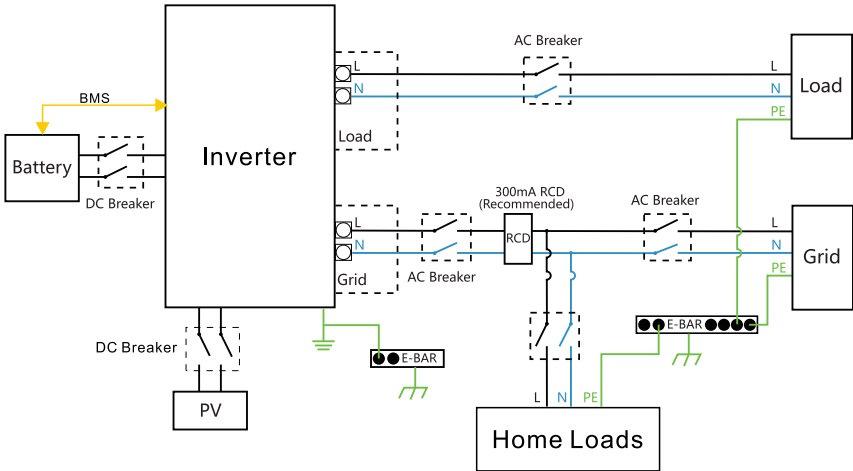

This diagram is an example for application that Neutral connects together with PE in distribution box.

Such as: Australia, New Zealand, etc. (Please follow local wiring regulations!)

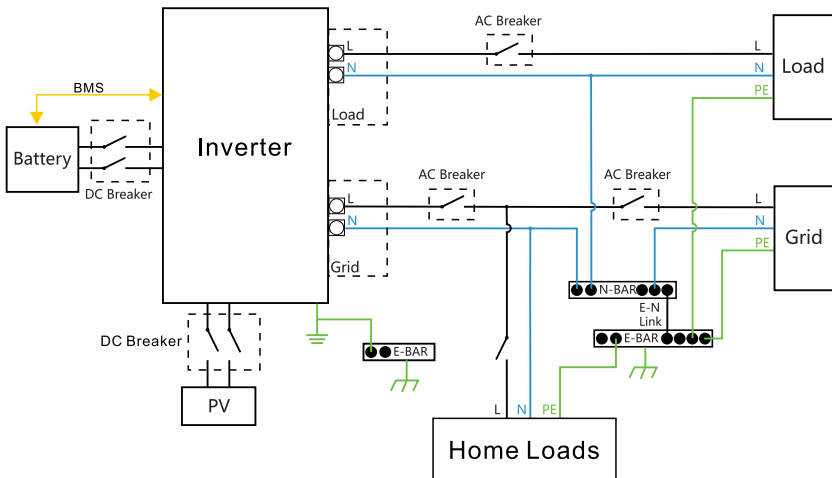

## 4. OPERATION

### 4.1 Power ON/OFF

After the unit has been properly installed and the batteries are securely connected, press the ON/OFF button (located on the left side of the case) to turn on the unit. When system without battery connected, but connect with either PV or grid, and ON/OFF button is switched off, LCD will still light up, In this condition, when switch on ON/OFF button and select NO battery, system can still work.

### 4.2 Operation and Display Panel

The operation and display panel, shown in below chart, is on the front panel of the inverter. It includes four function keys, one LED indicator, and a LCD display, indicating the operating status and input/output power information.

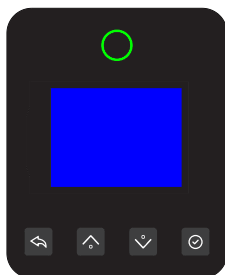

Function Key	Icon	Description
ESC		1.To exit setting mode. 2.To enter the system setup screen, when on the Main Screen.
Up		1. To go to previous selection. 2. To decrease the setting value.
Down		1. To go to next selection. 2. To increase the setting value.
Enter		1.To confirm the selection. 2.To enter the information page, when on the Main Screen.
Buzzer Information		
Buzzer beep	When the buzzer is enabled, it will keep beeping if the inverter experiences a fault.	

## 5. LCD Display Icons

### 5.1 Boot Screen

After power-on, the system enters the boot screen and remains there for about 20 seconds while it completes the system initialization.



### 5.2 Main Screen

1. The LCD is a color screen, below screen shows the overall information of the inverter.

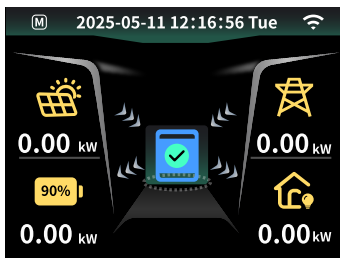

Operating status	Icon	Color	Description
Normal operation		Green	The icon in the center of the home screen indicates that the system is in normal operation.
Standby		White	The icon in the center of the home screen indicates that the system is standby.
Fault		Red	If it turns into red and shows "!", it means the inverter has fault,
Warning		Yellow	If it turns into yellow, it means the inverter has warning

2. At the top of the screen is the time (year-month-day,time), and communication connection status.

**(M)**: Parallel system master or slave flag.

**📶**: WIFI communication success.

3. Press the ESC button, you can enter into the system setup screen which including Information, Basic Setup, Battery Setup, Grid Setup, Load Setup, Mode Setup, Advanced Setup, and History Fault.

The main screen includes the icons for PV (left up), grid (right up), battery (left bottom), load (right bottom). It also displays the energy flow direction using arrows. After pressing the Up or Down key to switch icons, press the Enter key to view the information related to the selected icon.

Some clarifications about the system status are as follows:

- PV power will always be positive.
- Grid power negative means sell to grid, positive means get from grid.
- Load power will always be positive.
- Battery power negative means discharge, positive means charge.

### 5.2.1 Power-on Instructions

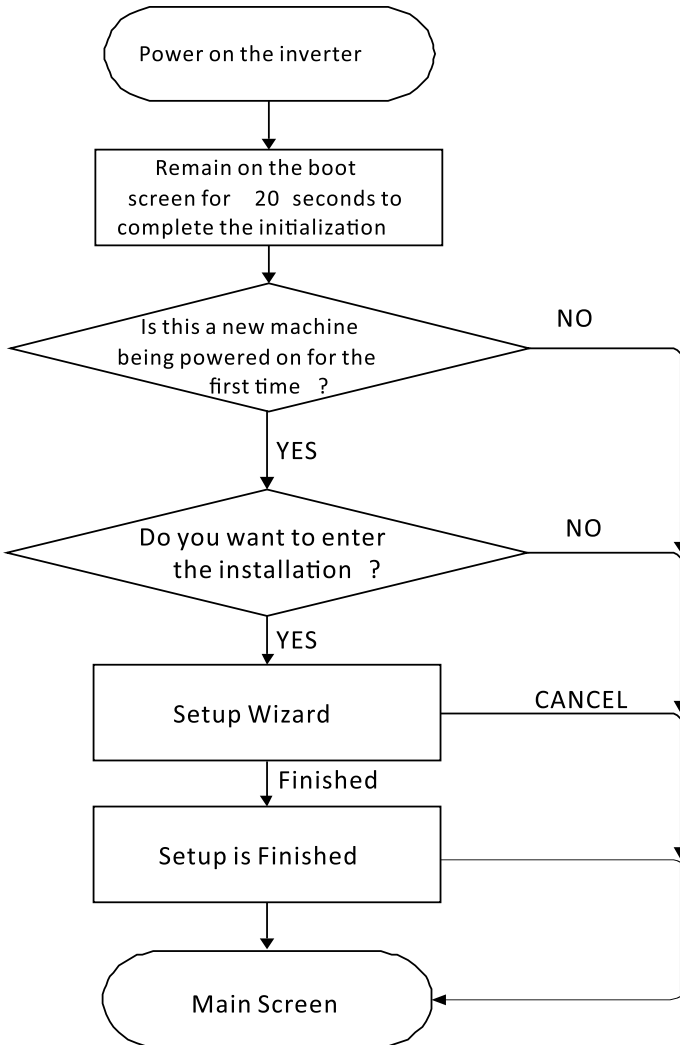

### 5.2.2 LCD operation flow chart

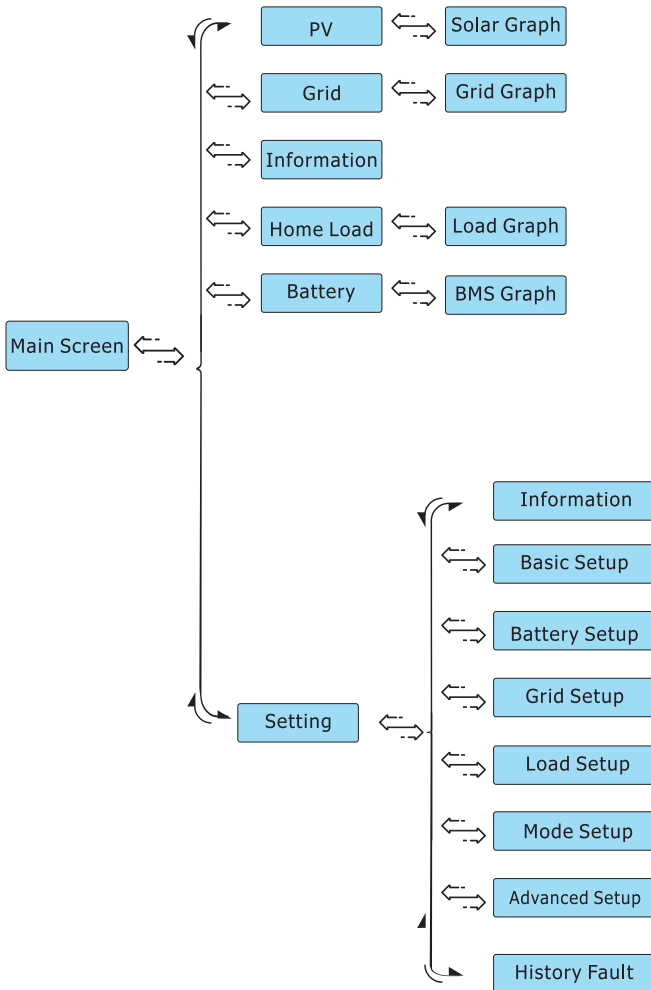

### 5.2.3 Setup Wizard Steps

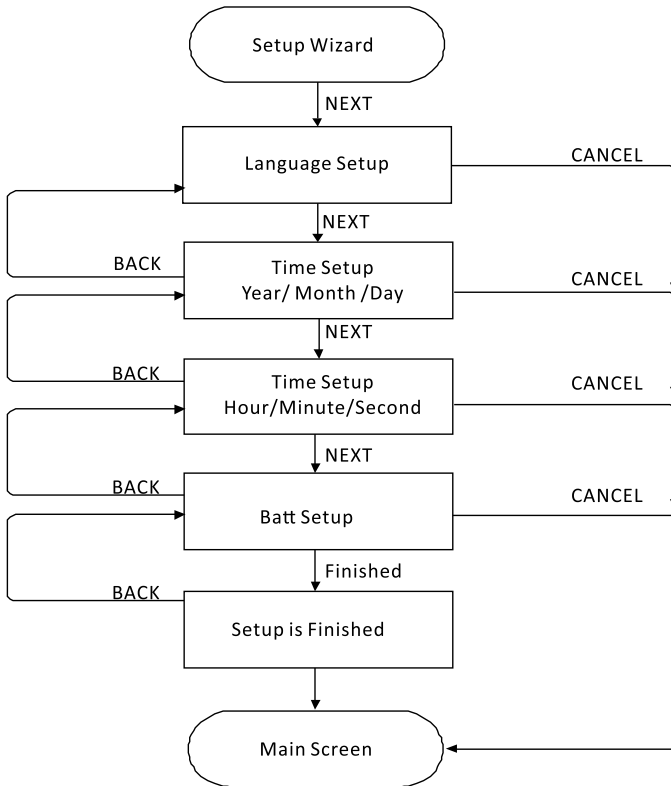

### 5.3 Base Information Page

PV			
Power	Today	0.00kWh	
0.00kW	Total	0.00kWh	
Voltage	0V	Current	0.0A

**This is Solar Panel detail page.**

**Power:** Current solar panel generation power.  
**Today/Total:** Today's and total generation energy.  
**Voltage/Current:** Voltage and current of MPPT at the current time.

Grid			
Power	Voltage	0.0V	
0.00kW	Frequency	50.0Hz	
Today Import	Total Import	0.00kWh	
Export	Export	0.00kWh	

**This is Grid detail page.**

**Power:** Power detected by internal sensors on AC grid input port.  
**Voltage:** The AC voltage on the grid port at current time.  
**Frequency:** The AC frequency on the grid port at current time.  
**Today Import/Export:** Today's import energy from grid to the inverter, and export energy from inverter to the grid.  
**Total Import/Export:** Total import energy from grid to the inverter, and export energy from inverter to the grid.

Information			
MCU Ver	00-000-00	BUS	380.0V
HMI Ver	00-000-00	INV	230.0V/10.0A
WIFI Ver	00-000-00	Temp.	25/25/25/25°C
BMS Ver	00-000-00	HW	0x0000 0x0000
Model	IVDM4224P1G3		
SN	526480004433366100	Score	0x0000

**This is Inverter information page.**

**MCU Ver/HMI Ver/WIFI Ver/BMS Ver/HW:** The version information of firmware.  
**BUS:** Voltage of BUS at the current time.  
**INV:** Voltage and current of inverter at the current time.  
**Temp.:** Temperatures of each NTC sensor at the current time.  
**Model:** Model name of this unit.  
**Score:** Model code of this unit.  
**SN:** The series number of inverter.

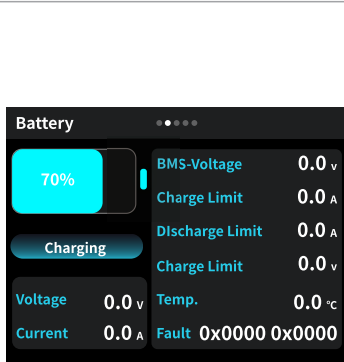

**This is Battery detail page.**

**SOC:** The SOC of battery uploaded by BMS.

**Charging:** The operating status of battery.

**Voltage:** The voltage of battery.

**Current:** The current of battery. Positive values indicate charge current, and negative values indicate discharge current.

**BMS-Voltage:** The voltage of battery uploaded by BMS.

**Charge Limit:** The charge current limit of battery.

**Discharge Limit:** The discharge current limit of battery.

**Charge Limit:** The charge voltage limit of battery.

**Temp.:** Battery temperature.

- User-defined Mode: Sampled temperature;

- Lithium Mode: BMS temperature.

**Fault:** The fault code of battery uploaded by BMS.

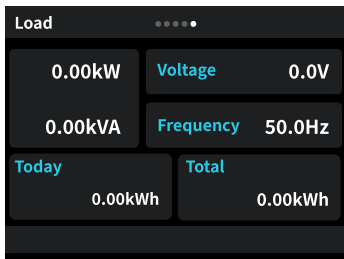

**This is Load detail page.**

**Power:** The power consumption of the home load at the current time.

**Voltage:** The AC voltage on the load part of the inverter.

**Frequency:** The AC frequency on the load part of the inverter.

**Today / Total:** Today's and total load consumption energy.

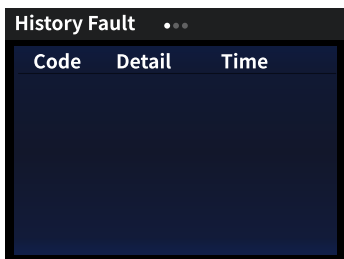

**This is Fault Code page.**

**Code:** Code of this fault.

**Detail:** Detailed information of this fault.

**Time:** Occurrence time of this fault.

## 5.4 Setting Menu

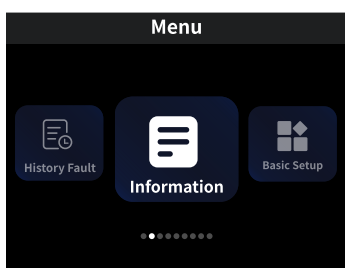
	<p><b>This is Setting menu page.</b>          Use the Up and Down keys to navigate the settings menu, then press Enter key to enter. This menu includes Information, Basic Setup, Battery Setup, Grid Setup, Load Setup, Mode Setup, Advanced Setup, and History Fault.</p>
---	---

### ① Basic Setup

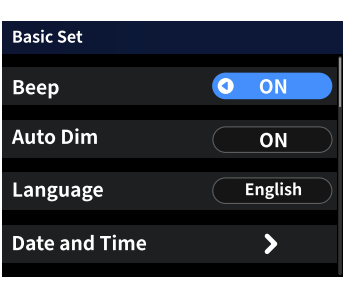
	<p><b>This is Basic Setup page.</b>  <b>Beep:</b> Enables or disables the buzzer during fault occurrence. Default: ON.  <b>Auto Dim:</b> When it's enabled, the LCD screen will be dim automatically after 5 minutes of non-operation. Default: ON.  <b>Language:</b> After pressing Enter key, use the Up and Down keys to switch the language. Options: English. Default: English.  <b>Date and Time:</b> To set the local day and time for the inverter.</p>
---	---

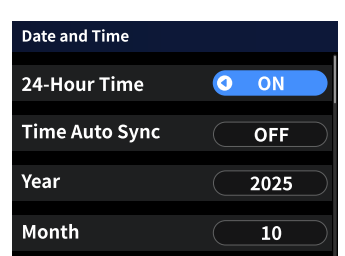
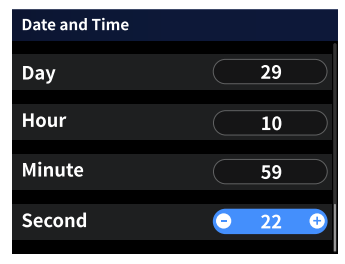
	<p><b>24-Hour Time:</b> Choose between 12-hour or 24-hour display time. When it's enabled, time is displayed in 24-hour format. Default: ON.  <b>Time Auto Sync:</b> After enabling, when the inverter is communicating with the cloud platform via data logger, the inverter will keep the time in sync with cloud platform automatically. Default: ON.  <b>Year/Month/Day/Hour/Minute/Second:</b> After pressing Enter key, use the Up and Down keys to change the value.</p>
	

② Battery Setup

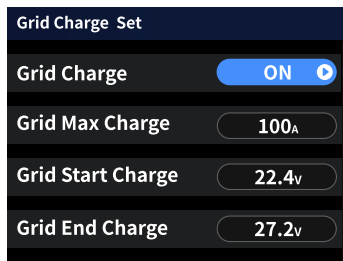
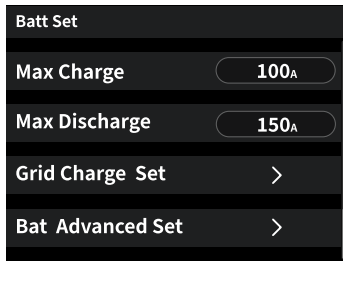
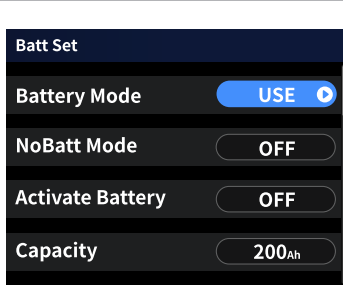

**This is Battery Setup page.**

**Battery Mode:** Battery types include User Defined and Lithium Battery. Default: USE.

**NoBatt Mode:** Set whether Battery-Less Mode is enabled. If enabled, when a battery open circuit is detected, the inverter will power the load from PV and mains. Otherwise, the unit will not work when the battery is open circuit. Default: OFF.

**Activate Battery:** This feature helps recover a battery that has been over-discharged by slowly charging from the solar array or grid. Default: ON.

**Capacity:** The total capacity of battery connected to this system, it can be used to calculate the SOC of battery bank under the "Batt SOC" mode. Default: 300Ah.

**Max Charge:** Max battery charging current. Default: 60A.

**Max Discharge:** Max battery discharging current. Default: 160A.

For AGM and Flooded, we recommend Ah battery size x 20% = Charge/Discharge amps.

For Lithium, we recommend Ah battery size x 50% = Charge/Discharge amps.

For Gel, follow manufacturer's instructions.

**Grid Charge Set:** Settings for charging the battery from the grid.

**Bat Advanced Set:** More advanced battery settings.

**Grid Charge:** It's allowed to absorb AC power from the grid port to charge the battery. Default: ON.

**Grid Max Charge:** The maximum charging current allowed when only use AC power from the grid port to charge the battery. When setting this value, it cannot exceed the "Max Charge" (maximum charging current) setting. Default: 60A.

**Grid Start Charge:** When the battery SOC or voltage drops to this set value, the inverter will auto start charge the battery from the grid port. Default: 20% SOC or 23V.

**Grid End Charge:** When the battery SOC or voltage reaches this set value, the inverter will end charge the battery from the grid port. Default: 80% SOC or 27V.

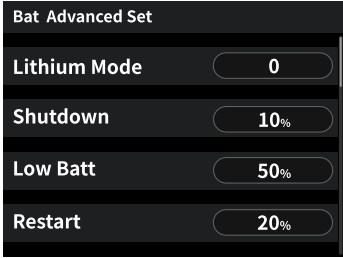
 <p><b>Bat Advanced Set</b></p> <p><b>Lithium Mode</b>      0</p> <p><b>Shutdown</b>            10%</p> <p><b>Low Batt</b>             50%</p> <p><b>Restart</b>                20%</p>	<p>When the "Lithium" mode is selected, The content on the "Bat Advanced Set" page is shown in the figure on the left.</p> <p><b>Lithium Mode:</b> This is the BMS communication protocol code which can be confirmed on the "Approved Battery list" based on the battery model you are using. Default: 0.</p> <p><b>Shutdown:</b> Battery can discharge to this SOC, then the DC/AC inverter module of this inverter will be shut down and the solar power can only be used to charge the battery. Default: 5% SOC.</p> <p><b>Low Batt:</b> When the battery SOC falls below the set value, a low battery voltage alarm will be triggered. Default: 10% SOC.</p> <p><b>Restart:</b> After the DC/AC inverter module of this inverter is shut down, the PV power can only be used to charge the battery. After the battery SOC has resumed to this "Restart" value, the DC/AC inverter module will restart to output AC power. Default: 15% SOC.</p>
--	--

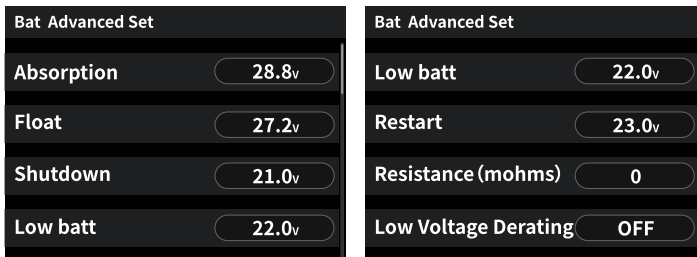

When the "User-Defined" mode is selected, the content on the "Bat Advanced Set" page is shown as the figure above.

Three-stage charging strategy for lead-acid and non-compatible lithium batteries.

If you are not familiar with these parameters, please keep the default values.

**Absorption:** The charging voltage during absorption charging stage. Default: 28.8V.

**Float:** The charging voltage during floating charging stage. Default: 27.2V.

**Shutdown:** When battery voltage drop to this value, then the DC/AC inverter module of this inverter will be shut down and the solar power can only be used to charge the battery. Default: 21V.

**Low Batt:** When the battery voltage falls below the set value, a low battery voltage alarm will be triggered. Default: 22V.

**Restart:** After the DC/AC inverter module of this inverter is shut down, the PV power can only be used to charge the battery. When the battery voltage has returned to this "Restart" value, the DC/AC inverter module will restart to output AC power. Default: 23V.

**Resistance (mohms):** The internal resistance of a battery refers to the opposition to current flow within the battery during operation. Default: 0mOhms.

**Low Voltage Derating:** If enabled, the output will be derated when powering a load under low battery voltage conditions. Default: ON.

**Recommended battery settings:**

Battery Type	Absorption Stage	Float Stage
AGM (or PCC)	14.2V (28.4V)	13.4V (26.8V)
Gel	14.1V (28.2V)	13.5V (27.0V)
Wet	14.7V (29.4V)	13.7V (27.4V)
Lithium	Follow its BMS voltage parameters	

In "USE"(User Defined) battery mode, you can set the "Absorption"(CV voltage) and "Float"(float voltage) based on your specific battery type (refer to the table above).

③ Grid Setup

<div style="background-color: #333; color: white; padding: 5px;"> <p><b>Grid Set</b></p> <p>Grid Mode <span style="float: right; border: 1px solid white; border-radius: 10px; padding: 2px 10px;">APL</span></p> <p>Rated Voltage <span style="float: right; border: 1px solid white; border-radius: 10px; padding: 2px 10px;">230v</span></p> <p>Rated Frequency <span style="float: right; border: 1px solid white; border-radius: 10px; padding: 2px 10px;">50Hz</span></p> <p>Current Limit <span style="float: right; border: 1px solid white; border-radius: 10px; padding: 2px 10px;">16A</span></p> <hr/> <p><b>Grid Set</b></p> <p>Rated Voltage <span style="float: right; border: 1px solid white; border-radius: 10px; padding: 2px 10px;">230v</span></p> <p>Rated Frequency <span style="float: right; border: 1px solid white; border-radius: 10px; padding: 2px 10px;">50Hz</span></p> <p>Current Limit <span style="float: right; border: 1px solid white; border-radius: 10px; padding: 2px 10px;">16A</span></p> <p>Grid Advanced Set <span style="float: right; border: 1px solid white; border-radius: 10px; padding: 2px 10px;">&gt;</span></p> </div>	<p><b>This is Grid Setup page.</b></p> <p><b>Grid Mode:</b> Set grid input voltage range, optional: APL,UPS. Default: APL.</p> <p><b>Rated Voltage:</b> Set the rated output voltage of the inverter, optional: 220V, 230V, 240V. Default: 230V.</p> <p><b>Rated Frequency:</b> Set according to the grid frequency in on-grid mode or the frequency required by the load in off-grid mode. optional: 50Hz, 60Hz. Default: 50Hz.</p> <p><b>Current Limit:</b> Set the maximum input current of grid port. Default: 28A.</p> <p><b>Grid Advanced Set:</b> More advanced grid settings.</p>
<div style="background-color: #333; color: white; padding: 5px;"> <p><b>Grid Advanced Set</b></p> <p>Grid Feed Enable <span style="float: right; border: 1px solid white; border-radius: 10px; padding: 2px 10px;">OFF</span></p> <p>Import Power Limit <span style="float: right; border: 1px solid white; border-radius: 10px; padding: 2px 10px;">3600w</span></p> <p>Export Power Limit <span style="float: right; border: 1px solid white; border-radius: 10px; padding: 2px 10px;">0w</span></p> <p>Grid Upper Limit <span style="float: right; border: 1px solid white; border-radius: 10px; padding: 2px 10px;">264.5v</span></p> <hr/> <p><b>Grid Advanced Set</b></p> <p>Export Power Limit <span style="float: right; border: 1px solid white; border-radius: 10px; padding: 2px 10px;">0w</span></p> <p>Grid Upper Limit <span style="float: right; border: 1px solid white; border-radius: 10px; padding: 2px 10px;">264.5v</span></p> <p>Grid Lower Limit <span style="float: right; border: 1px solid white; border-radius: 10px; padding: 2px 10px;">184v</span></p> <p>Island Check <span style="float: right; border: 1px solid white; border-radius: 10px; padding: 2px 10px;">OFF</span></p> </div>	<p><b>Grid Feed Enable:</b> Set whether grid feed is enabled. If enabled, the unit can feed power to the grid; if not, it cannot. Default: OFF.</p> <p><b>Import Power Limit:</b> Set the maximum input power of grid port. Default: 4200W.</p> <p><b>Export Power Limit:</b> Set the maximum power exported to the grid. Default: 500W.</p> <p><b>Grid Upper Limit:</b> Set the upper limit for the grid voltage. The unit will issue an alarm when the grid voltage exceeds this value. Default: 300V.</p> <p><b>Grid Lower Limit:</b> Set the lower limit for the grid voltage. The unit will issue an alarm when the grid voltage falls below this value. Default: 90V.</p> <p><b>Island Check:</b> If enabled, the unit will perform active islanding detection in on-grid mode. Default: OFF.</p>

#### ④ Load Setup

<div style="background-color: #1a2b3c; color: white; padding: 5px;">Load Set</div> <div style="background-color: #1a2b3c; color: white; padding: 5px;">On Grid Always On <span style="float: right; background-color: #007bff; color: white; border-radius: 10px; padding: 2px 10px;">ON</span></div> <div style="background-color: #1a2b3c; color: white; padding: 5px;">Off Grid Promptly Off <span style="float: right; border: 1px solid #ccc; border-radius: 10px; padding: 2px 10px;">OFF</span></div> <div style="background-color: #1a2b3c; color: white; padding: 5px;">PV Power <span style="float: right; border: 1px solid #ccc; border-radius: 10px; padding: 2px 10px;">0<sub>w</sub></span></div> <div style="background-color: #1a2b3c; color: white; padding: 5px;">ON <span style="float: right; border: 1px solid #ccc; border-radius: 10px; padding: 2px 10px;">50%</span></div>	<p><b>This is Load Setup page.</b>  <b>On Grid Always On:</b> When click "On Grid Always On", the smart load will switch on when the grid is present. Default: OFF.</p>
<div style="background-color: #1a2b3c; color: white; padding: 5px;">Load Set</div> <div style="background-color: #1a2b3c; color: white; padding: 5px;">OFF <span style="float: right; border: 1px solid #ccc; border-radius: 10px; padding: 2px 10px;">40%</span></div> <div style="background-color: #1a2b3c; color: white; padding: 5px;">Over Temp Restart <span style="float: right; border: 1px solid #ccc; border-radius: 10px; padding: 2px 10px;">OFF</span></div> <div style="background-color: #1a2b3c; color: white; padding: 5px;">Over Load Restart <span style="float: right; border: 1px solid #ccc; border-radius: 10px; padding: 2px 10px;">OFF</span></div> <div style="background-color: #1a2b3c; color: white; padding: 5px;">Over Load Bypass <span style="float: right; border: 1px solid #ccc; border-radius: 10px; padding: 2px 10px;">OFF</span></div>	<p><b>Off Grid Promptly off:</b> The smart load will stop working immediately when the grid is disconnected if this item is active. Default: OFF.</p> <p><b>PV Power:</b> The smart port will be activated when the PV power reaches or exceeds the set threshold. Default: 2100W. (This setting is valid only when the "Off Grid Promptly off" setting is disabled.)</p> <p><b>ON:</b> The smart port will be activated when the battery voltage/SOC reaches or exceeds the set threshold. Default: 80% SOC or 27.2V. (This setting is valid only when the "Off Grid Promptly off" setting is disabled.)</p> <p><b>OFF:</b> The smart port will be deactivated when the battery voltage/SOC falls to or below the set threshold. Default: 20% SOC or 23V. (This setting is valid only when the "Off Grid Promptly off" setting is disabled.)</p> <p>e.g. Power=2100W, ON=80%, OFF=20%. When the PV power exceeds 2100W, or battery bank SOC reaches 80%, Smart Load Port will switch on automatically and power the load connected. When the battery bank SOC &lt; 20% and PV power &lt; 2100W, the Smart Load Port will switch off automatically.</p> <p><b>Over Temp Restart:</b> Set the over-temperature restart function. If enabled, the inverter will automatically restore output three times at timed intervals after an over-temperature fault. If disabled, the fault will not be automatically cleared. Default: ON.</p> <p><b>Over Load Restart:</b> Set the overload restart function. If enabled, the inverter will automatically restore output three times at timed intervals after an overload fault. If disabled, the fault will not be automatically cleared. Default: ON.</p> <p><b>Over Load Bypass:</b> Set the overload-to-bypass function. If enabled, when the mains is present, the unit will switch to mains bypass to power the load after an overload condition. If disabled, the unit will trigger overload protection. Default: OFF.</p>

⑤ Mode Setup

<p>Mode Set</p> <p><b>Zero-Export Power</b> <span style="float: right; border: 1px solid white; border-radius: 15px; padding: 2px 10px;">20<sub>w</sub></span></p> <p><b>Energy Priority</b> <span style="float: right; border: 1px solid white; border-radius: 15px; padding: 2px 10px;">USB</span></p> <p><b>Max Solar Power</b> <span style="float: right; border: 1px solid white; border-radius: 15px; padding: 2px 10px;">6400<sub>w</sub></span></p> <p><b>Grid Peak Shaving</b> <span style="float: right; border: 1px solid white; border-radius: 15px; padding: 2px 10px;">OFF</span></p>	<p><b>This is Mode Setup page.</b></p> <p><b>Zero-Export Power:</b> To set the default power drawn from the grid in on-grid mode. If you do not want the inverter to sell power to the grid, set this value to prevent AC current from being output from the grid port of the inverter. Default: 100W.</p> <p><b>Energy Priority:</b> To set energy priority, optional: USB, SUB, SBU. Default: USB.</p> <ul style="list-style-type: none"> <li>- USB Backup Mode: Grid power takes priority for powering loads. PV is only used to supplement battery charging. When off-grid, loads are supported by both PV and the battery.</li> <li>- SUB Smart Mode: PV power is prioritized. The grid serves as a supplementary power source for load support or as an aid under current-limiting conditions. The off-grid logic is the same as in Backup Mode.</li> <li>- SBU Mode: The load priority is PV &gt; Battery &gt; Grid. The charge or discharge mode is determined based on the SOC (State of Charge) or voltage.</li> </ul> <p><b>Max Solar Power:</b> The maximum PV input power allowed. Default: 6400W.</p> <p><b>Grid Peak Shaving:</b> Grid Peak Shaving Function Enabled. When activated, the inverter will automatically limit the AC power input from the grid to the set value. If the sum of the grid peak shaving power, PV generation power, and battery power is still insufficient to meet the load power demand, the grid peak shaving function will be deactivated, and the grid input power can exceed the set value at this time. Default: OFF.</p> <p><b>Grid Peak Shaving:</b> Set this value to limit the AC power from the grid. If the grid peak shaving power plus PV power plus battery power cannot meet the power consumption of the load, the grid peak shaving will be invalid, and the power taken from the grid can exceed this set value. Default: 7500W.</p>
<p>Mode Set</p> <p><b>Energy Priority</b> <span style="float: right; border: 1px solid white; border-radius: 15px; padding: 2px 10px;">USB</span></p> <p><b>Max Solar Power</b> <span style="float: right; border: 1px solid white; border-radius: 15px; padding: 2px 10px;">6400<sub>w</sub></span></p> <p><b>Grid Peak Shaving</b> <span style="float: right; border: 1px solid white; border-radius: 15px; padding: 2px 10px;">OFF</span></p> <p><b>Grid Peak Shaving</b> <span style="float: right; border: 1px solid white; border-radius: 15px; padding: 2px 10px;">0<sub>w</sub></span></p>	

## ⑥ Advanced Setup

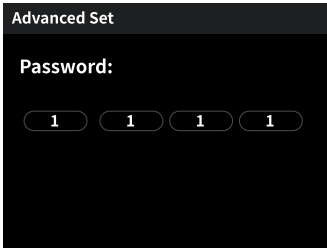

A password is required to access the Advanced Setup. The default password (initial password) is 1234.

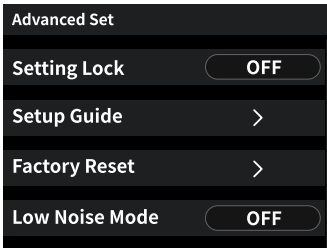

**This is Advanced Setup page.**

**Setting Lock:** If enabled, all settings except this one will be locked and cannot be modified. Default: OFF.

**Setup Guide:** Settings related to the setup wizard.

**Factory Reset:** Settings related to factory reset.

**Low Noise Mode:** In this mode, the sound emitted by the inverter during operation will be smaller. Default: OFF.

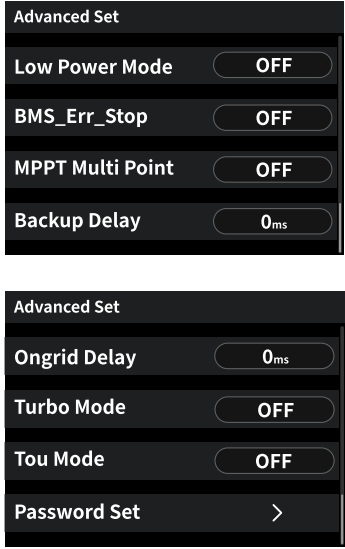
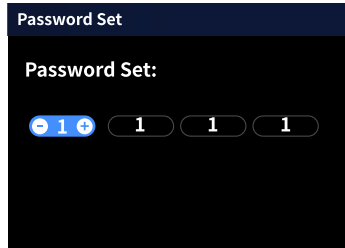
	<p><b>Low Power Mode:</b> If enabled, in off-grid mode, the inverter will shut down when the output power drops below 50w for a while. If the detected power exceeds 50W, the inverter will keep the output on. Default: OFF.</p> <p><b>BMS_Err_Stop:</b> When it is active, if the battery BMS failed to communicate with inverter, the inverter will stop working and report fault. Default: OFF.</p> <p><b>MPPT Multi Point:</b> The inverter will check whether the PV is working on its Max.power point. If not, then it will adjust the voltage of MPPT to ensure the PV operates at the Max. power point. Default: OFF.</p> <p><b>Backup Delay:</b> When the grid cuts off, the inverter will output power after this set time. Default: 0ms.</p> <p><b>Ongrid Delay:</b> When grid power is restored, the unit will wait for the set time before switching from off-grid mode to on-grid mode. Default: 15000ms.</p> <p><b>Turbo Mode:</b> If enable this function, inverter starts the overload derated output. (The Turbo mode is disabled in the following three scenarios: The mains is connected and in mains mode; The mains is set to UPS mode; When the Turbo mode is set to off.) Default: OFF.</p> <p><b>Tou Mode:</b> Set the scheduled charge/discharge function. Turn on or off the TOU function. Default: OFF.</p> <p><b>Password Set:</b> A password can be set for entering Advanced Set.</p>
	<p>Use the Up and Down keys to select the password digit to modify. Press the Enter key, then use the Up and Down keys to change the digit. After selecting the desired digit, press the Enter key to confirm.</p>

⑦ **History Fault**

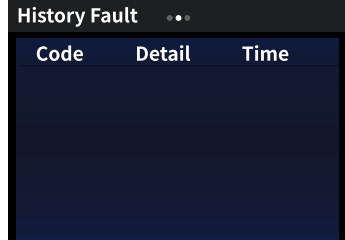
	<p><b>This is History Fault page.</b>          This page is used to record the historical faults of inverter, with a maximum of twenty entries. For detailed information, please refer to the "Warning code" and "Fault code" in the manual.</p>
---	--

### 5.4.1 Setup Wizard

Use the Up and Down keys to select the setting items. Press the Enter key, then use the Up and Down keys to change the options. After selecting the desired option, press the Enter key to proceed to the next setting. Press the ESC key to return to the previous setting or exit setup and go to the main screen.

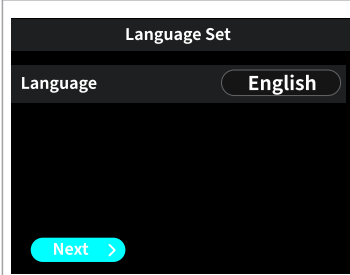
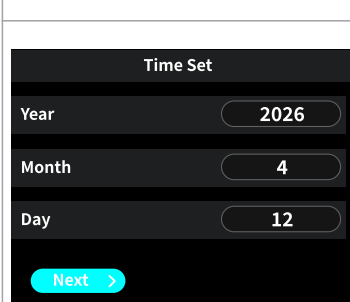
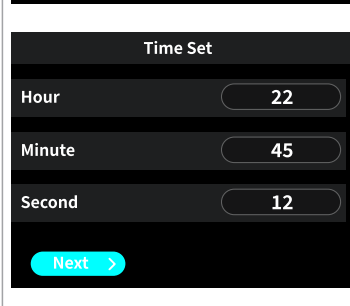
 <p>The screenshot shows a 'Language Set' screen with a dark background. At the top, it says 'Language Set'. Below that, 'Language' is displayed next to a button labeled 'English'. At the bottom left, there is a cyan button labeled 'Next &gt;'.</p>	<p><b>Step 1: Language Setup</b>  <b>Language:</b> Set the display language. Default: English.</p>
 <p>The screenshot shows a 'Time Set' screen for date configuration. It has three rows: 'Year' with a button showing '2026', 'Month' with a button showing '4', and 'Day' with a button showing '12'. A cyan 'Next &gt;' button is at the bottom left.</p>	<p><b>Year/Mon/Day/Hour/Min/Sec:</b> Press the Up and Down keys can change the selected number to set the current time and date.</p>
 <p>The screenshot shows a 'Time Set' screen for time configuration. It has three rows: 'Hour' with a button showing '22', 'Minute' with a button showing '45', and 'Second' with a button showing '12'. A cyan 'Next &gt;' button is at the bottom left.</p>	

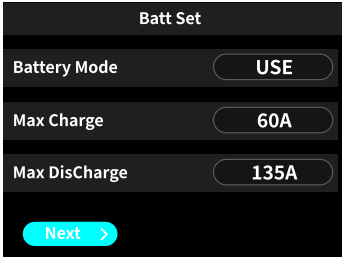
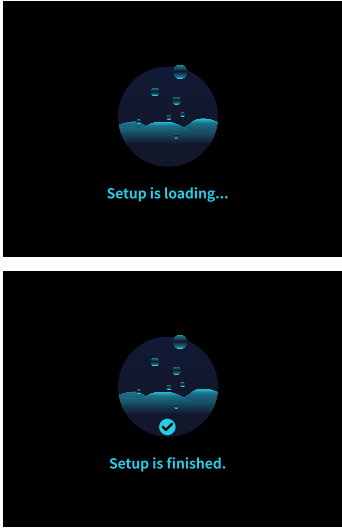
	<p><b>Battery Mode:</b> Set the battery mode, including three options. Default: USE.</p> <p><b>Max Charge:</b> Max battery charging current. Default: 60A.</p> <p><b>Max Discharge:</b> Max battery discharging current. Default: 160A.</p> <p>For AGM and Flooded, we recommend Ah battery size x 20% = Charge / Discharge amps.          For Lithium, we recommend Ah battery size x 50% = Charge / Discharge amps.          For Gel, follow manufacturer's instructions.</p>
	<p>After waiting ten seconds, the setup will be completed.</p>

## 6. Mode

### Mode I: Zero Export to Load

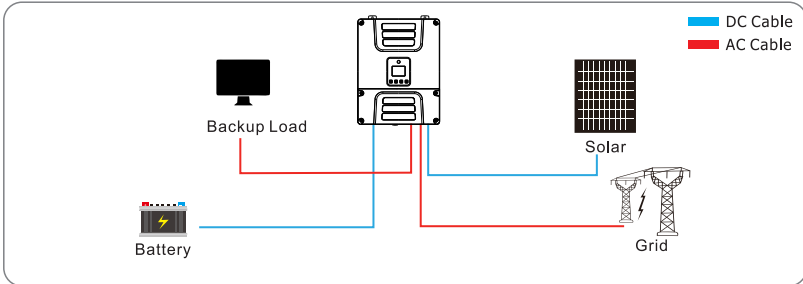

### Mode II: Off-grid

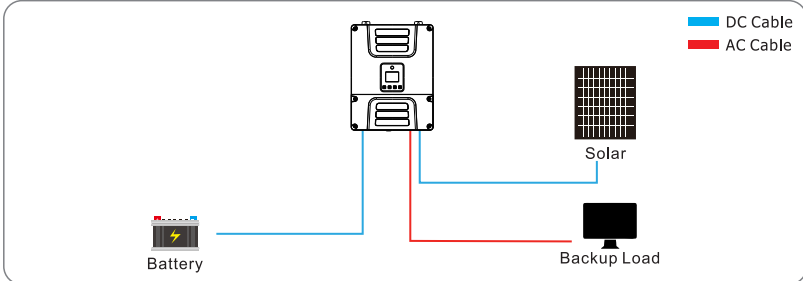

The 1st priority power of the system is always the PV power, then 2nd and 3rd priority power will be the battery bank or grid according to the settings.

## 7. Fault information and processing

### 7.1 Preparations for Installation

The energy storage inverter is designed according to the grid-connected operation standard and meets the safety requirements and electromagnetic compatibility requirements. Before leaving the factory, the inverter undergoes several rigorous tests to ensure that the inverter can operate reliably.

**Note**

If your inverter shows the Fault Code and the fault persists after restarting, please contact your local dealer or service center. You need to prepare the following information.

1. Inverter serial number;
2. Distributor or service center of the inverter ;
3. On-grid power generation date;
4. Please describe the problem in as much detail as possible (including the fault code and indicator light status). To help you understand the inverter's fault information more clearly, we will list all possible fault codes and their descriptions when the inverter is not functioning properly.
5. Your contact information.

## 7.2 Warning Code

Warning Code	Warning Information	Trouble Shooting
W02	Battery low voltage alarm	Battery voltage is too low or Battery SOC is too low, the battery should be charged.
W04	Battery open-circuit alarm	Please connect the battery.
W05	Grid over-voltage alarm	Please check the voltage of Grid. It should be less than the "Grid Upper Limit" setting(Default: 300V).
W06	Grid low voltage alarm	Please check the voltage of Grid. It should be greater than the "Grid Lower Limit" setting(Default: APL:90V, UPS:160V).
W07	Grid over-frequency alarm	Please check the frequency of Grid. It should be less than 65hz.
W08	Grid under-frequency alarm	Please check the frequency of Grid. It should be greater than 40hz.
W10	Grid overload alarm	1.Please check whether the load power is within the specified range; 2.Restart the unit, if the alarm still exists, please contact us for help.
W11	Active anti-islanding alarm	Confirm and disconnect the lines connected to the mains power supply.
W25	Load overload alarm	The load is overloaded and should be reduced.
W26	Fan alarm	1.Fan malfunction, check fan for proper functioning; 2.Check if the Fan wiring connected well. If the alarm still exists, replace the fan.
W34	Battery low voltage derating alarm	Reduce the load and charge the battery.
W56	PV boost NTC open alarm	Restart the unit, if the alarm still exists, please contact us for help.
W57	PV over-voltage alarm	1.Please check the component voltage, which should be less than 500V; 2.Restart the unit, if the alarm still exists, please contact us for help.
W61	PV over-current alarm	1.Reduce the loads; 2.Restart the unit, if the alarm still exists, please contact us for help.
W63	PV over-temperature alarm	1.Please check whether the air flow of the unit is blocked or whether the work environment temperature is too high; 2.Turn off the inverter for 15mins and restart; 3.Seek help from us, if can not go back to normal state.
W65	PV hardware over-current alarm	1.Reduce the loads; 2.Restart the unit, if the alarm still exists, please contact us for help.

### 7.3 Fault Code

Fault Code	Fault Information	Trouble Shooting
F14	Battery over-voltage fault	1.Please check whether the battery voltage is within the specified range; 2.Check whether Battery cables are firmly and correctly connected; 3.Restart the unit, if the fault still exists, please contact us for help.
F16	Battery over-current fault	Restart the unit, if the fault still exists, please contact us for help.
F21	DCDC over-current fault	1.Reduce the loads; 2.Restart the unit, if the fault still exists, please contact us for help.
F26	LLC hardware over-current fault	1.Reduce the loads; 2.Restart the unit, if the fault still exists, please contact us for help.
F27	LLC high-voltage side over-temperature fault	1.Please check whether the air flow of the unit is blocked or whether the work environment temperature is too high; 2.Turn off the inverter for 15mins and restart; 3.Seek help from us, if can not go back to normal state.
F28	LLC transformer over-temperature fault	1.Please check whether the air flow of the unit is blocked or whether the work environment temperature is too high; 2.Turn off the inverter for 15mins and restart; 3.Seek help from us, if can not go back to normal state.
F29	Bus over-voltage fault	1.Check if spec and quantity of batteries are meet requirements; 2.Restart the unit, if the fault still exists, please contact us for help.
F30	Bus hardware over-voltage fault	1.Check if spec and quantity of batteries are meet requirements; 2.Restart the unit, if the fault still exists, please contact us for help.
F31	Bus low voltage fault	Restart the unit, if the fault still exists, please contact us for help.
F32	Bus soft-start fault	Restart the unit, if the fault still exists, please contact us for help.
F34	INV soft-start fault	Restart the unit, if the fault still exists, please contact us for help.
F35	INV over-voltage fault	Restart the unit, if the fault still exists, please contact us for help.

F36	INV over-current fault	<ol style="list-style-type: none"> <li>1.Please check whether the load power is within the specified range;</li> <li>2.Restart the unit, if the fault still exists, please contact us for help.</li> </ol>
F37	INV hardware over-current fault	<ol style="list-style-type: none"> <li>1.Please check whether the load power is within the specified range;</li> <li>2.Restart the unit, if the fault still exists, please contact us for help.</li> </ol>
F38	INV short circuit fault	<ol style="list-style-type: none"> <li>1.Please check whether the load connection is firm and correct, remove abnormal load;</li> <li>2.Restart the unit, if the fault still exists, please contact us for help.</li> </ol>
F48	Load overload fault	<ol style="list-style-type: none"> <li>1.Please check whether the load power is within the specified range;</li> <li>2.Restart the unit, if the fault still exists, please contact us for help.</li> </ol>
F49	Output under-voltage fault	<ol style="list-style-type: none"> <li>1.Please check whether the load power is within the specified range;</li> <li>2.Restart the unit, if the fault still exists, please contact us for help.</li> </ol>
F50	Output over-voltage fault	Restart the unit, if the fault still exists, please contact us for help.
F56	Eeprom fault	Restart the unit, if the fault still exists, please contact us for help.
F78	DCDC current sensor fault	Restart the unit, if the fault still exists, please contact us for help.
F79	INV current sensor fault	Restart the unit, if the fault still exists, please contact us for help.
F81	Grid current sensor fault	Restart the unit, if the fault still exists, please contact us for help.
F83	PV current sensor fault	Restart the unit, if the fault still exists, please contact us for help.
F85	Bootload fault	Restart the unit, if the fault still exists, please contact us for help.
F89	Battery pos-terminal NTC open or over-temp fault	<ol style="list-style-type: none"> <li>1.Please check whether the air flow of the unit is blocked or whether the work environment temperature is too high;</li> <li>2.Turn off the inverter for 15mins and restart;</li> <li>3.Seek help from us, if can not go back to normal state.</li> </ol>
F90	Battery neg-terminal NTC open or over-temp fault	<ol style="list-style-type: none"> <li>1.Please check whether the air flow of the unit is blocked or whether the work environment temperature is too high;</li> <li>2.Turn off the inverter for 15mins and restart;</li> <li>3.Seek help from us, if can not go back to normal state.</li> </ol>
F91	Mains over-current fault	<ol style="list-style-type: none"> <li>1.Reduce the loads;</li> <li>2.Restart the unit, if the fault still exists, please contact us for help.</li> </ol>

F92	Output over-current fault	1.Reduce the loads; 2.Restart the unit, if the fault still exists, please contact us for help.
F93	Model identification fault	Restart the unit, if the fault still exists, please contact us for help.
F94	Battery hardware over-voltage fault	1.Please check whether the battery voltage is within the specified range; 2.Check whether Battery cables are firmly and correctly connected; 3.Restart the unit, if the fault still exists, please contact us for help.

Under the guidance of our company, customers return our products so that our company can provide service of maintenance or replacement of products of the same value. Customers need to pay the necessary freight and other related costs. Any replacement or repair of the product will cover the remaining warranty period of the product. If any part of the product or product is replaced by the company itself during the warranty period, all rights and interests of the replacement product or component belong to the company.

Factory warranty does not include damage due to the following reasons:

- Damage during transportation of equipment ;
- Damage caused by incorrect installation or commissioning ;
- Damage caused by failure to comply with operation instructions, installation instructions or maintenance instructions ;
- Damage caused by attempts to modify, alter or repair products ;
- Damage caused by incorrect use or operation ;
- Damage caused by insufficient ventilation of equipment ;
- Damage caused by failure to comply with applicable safety standards or regulations ;
- Damage caused by natural disasters or force majeure (e.g. floods, lightning, overvoltage, storms, fires, etc.)

In addition, normal wear or any other failure will not affect the basic operation of the product. Any external scratches, stains or natural mechanical wear does not represent a defect in the product.

## 8.Limitation of Liability

In addition to the product warranty described above, the state and local laws and regulations provide financial compensation for the product's power connection (including violation of implied terms and warranties). The company hereby declares that the terms and conditions of the product and the policy cannot and can only legally exclude all liability within a limited scope.

## 9. Datasheet

Model	IVDM4224P1G3
<b>Battery Input Data</b>	
Battery Type	Lead-acid or Lithium-ion
Battery Voltage Range(V)	20~30
Max. Charging Current(A)	160
Max. Discharging Current(A)	160
Charging Strategy for Li-Ion Battery	Self-adaptation to BMS
Number of Battery Input	1
<b>PV String Input Data</b>	
Max. PV access power(W)	10000
Max. PV Input Power(W)	8000
Max. PV Input Voltage(V)	500
Start-up Voltage(V)	60
PV Input Voltage Range(V)	60~500
MPPT Voltage Range(V)	60~425
Full Load MPPT Voltage Range(V)	300~425
Rated PV Input Voltage(V)	370
Max. Operating PV Input Current(A)	20
Max. Input Short-Circuit Current(A)	27
No. of MPP Trackers	1
Max. Inverter Backfeed Current to The Array(A)	0
<b>AC Output Data</b>	
Rated AC Output Power(VA/W)	4200
Max. AC Output Power(VA/W)	4620
Max. AC Output Current(A)	20
Peak Power(W)	2 times of rated power, 10s
Rated Output Voltage(V)	230
Output Type	L+N+PE
Rated Output Frequency	50Hz/60Hz
Output Voltage Waveform	Pure Sine Wave
Total Current Harmonic Distortion THDi	<3%
<b>AC Input Data(Grid)</b>	
Max. Input Power to Battery(W)	4200
Rated Input Voltage(V)	230
Rated Input Frequency	50Hz/60Hz
Grid Input Current(A)	25

<b>Efficiency</b>	
Max. Efficiency	97.60%
Euro Efficiency	96.50%
MPPT Efficiency	>99%
<b>Equipment Protection</b>	
DC reverse polarity protection	Yes
AC Output Overcurrent Protection	Yes
AC Output Overvoltage Protection	Yes
AC Output Short Circuit Protection	Yes
Thermal Protection	Yes
Overvoltage Load Drop Protection	Yes
DC Component Monitoring	Yes
Surge Protection Level	TYPE II(DC), TYPE II(AC)
<b>Interface</b>	
Display	LCD+LED
Communication Interface	RS485, CAN
Monitor Mode	WIFI/LAN(optional)
<b>General Data</b>	
Operating Temperature Range	-40 to +60°C, >45°C Derating
Permissible Ambient Humidity	0-100%
Permissible Altitude	3000m
Noise	<46 dB
Ingress Protection(IP) Rating	IP6X
Inverter Topology	Non-Isolated
Over Voltage Category	OVC II (DC), OVC III (AC)
Warranty	5 Years More Info Please Refer to Warranty Policy
Type of Cooling	Intelligent Air Cooling
Net Weight	8.3kg
Gross weight	10.3kg
Product Dimension	403x313x137mm
Package Dimension	495x405x227mm
Safety EMC/Standard	IEC/EN 61000-6-1/2/3/4, IEC/EN 62109-1, IEC/EN 62109-2

## 10. Appendix I

Pin Assignment for Inverter CAN/RS485 Communication Port

No.	CAN/RS485 Pin
1	NC
2	NC
3	CAN-L
4	CAN-H
5	RS485-B
6	RS485-A
7	NC
8	NC

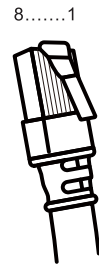

## 11. The Wi-Fi operation Guide in APP

### 11.1 Introduction

Wireless communication between the off-grid inverter and theAPP can be realized through the Wi-Fi module.The APP supports Android and iOS devices.

Delivers device status during normal operation.

Allows device Settings to be configured on the APP.

Notifies users when a warning or alarm occurs.

Allows users to query inverter history data.

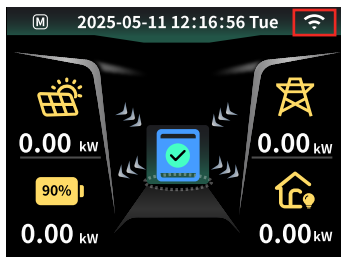

The status of the Wi-Fi sign on the LCD display.

After the APP is successfully connected,Wi-Fi indicator light remains constantly on.

### 11.2 Download and install APP

***Operating system requirement for your smart phone:***

 iOS system supports iOS 11.0 and above

 Android system supports Android 5.0 above

APP Download

Please scan the following QR code with your smartphone to download the App.



The QR code supports Android system and iOS system

### **Operation Manual**

Please scan the following QR code with your smartphone to view the App Operation Manual



The QR code supports Android system and iOS system

**Guangzhou Felicity Solar Technology Co., Ltd.**

✉ Email: [sales@felicitysolar.com](mailto:sales@felicitysolar.com)

🌐 Web: [www.felicitysolar.com](http://www.felicitysolar.com)

📍 Add: (Airport Baiyun)No.2, 4, 6, 8, 10 and 12 Donghua Huaye Road, Renhe Town, Baiyun District, Guangzhou, Guangdong, P. R. China