

USER MANUAL

Off-Grid Solar Inverter

IVPM8048P1G2-PRO
IVPM10048P1G2-PRO
IVPM12048P1G2-PRO
IVPM16048P1G2-PRO



Contents

1. Safety Introductions	1
2.Product Introductions	2
2.1 Product Overview.....	3
2.2 Product Dimensions.....	5
2.3 Product Features.....	7
2.4 Basic System Architecture.....	7
3. Installation	8
3.1 Parts List.....	8
3.2 Product handling requirements.....	9
3.3 Mounting instructions.....	9
3.4 Battery connection.....	13
3.4.1 Function port definition.....	15
3.4.2 Temperature sensor connection for lead-acid battery.....	17
3.5 Grid connection and backup load connection.....	19
3.6 PV Connection.....	22
3.6.1 PV Module Selection:.....	22
3.6.2 PV Module Wire Connection:.....	22
3.7 Earth Connection(mandatory).....	24
3.8 WIFI Connection.....	25
3.9 Wiring System for Inverter.....	25
3.10 Typical application diagram of diesel generator.....	26
3.11 Single phase parallel connection diagram.....	28
3.12 Three phase Parallel Inverter.....	30
4.Operation	32
4.1 Power ON/OFF.....	32
4.2 Operation and Display Panel.....	32
5.LCD Display Icons	33
5.1 Boot Screen.....	33
5.2 Main Screen.....	33
5.2.1 Power-on Instructions.....	35
5.2.2 LCD operation flow chart.....	36
5.2.3 Setup Wizard Steps.....	37

5.3 Solar Power Curve.....	38
5.4 Curve Page-Solar & Load & Grid & Generator & Smart Load.....	40
5.5 Setting Menu.....	40
5.6 Battery Setting.....	41
5.7 Grid Setting.....	43
5.8 Setup Wizard.....	44
5.9 System Work Mode.....	47
5.10 Basic Setting.....	48
5.11 Grid Setting.....	49
5.12 Advanced Function.....	50
5.13 Advanced Function.....	50
6. Mode.....	51
7.Fault Information and Processing.....	56
7.1 Warning Code.....	57
7.2 Fault Code.....	58
8.Limitation of Liability.....	62
9.Datasheet.....	63
10.Appendix I.....	65
11.The Wi-Fi operation Guide in APP.....	65
11.1 Introduction.....	65
11.2 Download and install App.....	66

Revision History

Revision No.	Revision Date	Revision Reason
1.0	2026.4	First Published

About This Manual









This manual mainly describes product information, installation, operation, and maintenance guidelines. It does not cover all aspects of the photovoltaic (PV) system.

How to Use This Manual

Read this manual and all related documents carefully before operating the inverter. Keep all documents properly stored and readily available for reference.

Contents may be periodically updated or revised due to product development. The information in this manual is subject to change without notice. The latest manual can be acquired via <https://www.felicitysolar.com/>

1. Safety Introductions

Symbols	Name	Instruction
	Danger	Serious injury or death may occur if the relevant safety requirements are not followed.
	Warning	Physical injury or equipment damage may occur if the relevant requirements are not followed.
	Electrostatic sensitive	Damage may occur if the relevant anti-static requirements are not followed.
	Hot surface	Sides of the device may become hot. Do not touch.
	Earth terminal	The inverter must be reliably grounded.
	Caution	Ensure that both DC and AC circuit breakers are disconnected, and wait at least 5 minutes before wiring or inspection.
NOTE	Note	The procedures taken for ensuring proper operation.
	CE mark	The inverter complies with the CE directive.
	EU WEEE mark	Product should not be disposed as household waste.

- This chapter provides important safety and operating instructions. Read and retain this manual for future reference.
- Before using the inverter, please read the battery instructions, warning signs, and related sections of this manual.
- Do not disassemble the inverter. For maintenance or repair, contact a qualified service center.
- Improper reassembly may cause electric shock or fire.
- To reduce the risk of electric shock, disconnect all wires before performing any maintenance or cleaning. Turning off the unit alone will not eliminate this risk.
- Caution: Only qualified personnel should install this device with a battery.
- Never charge a frozen battery.
- For optimal operation, follow the required specifications to select the correct cable size. Proper installation is essential for reliable performance.
- Be cautious when working with metal tools around batteries. Dropping a tool may cause sparks, short circuits, or even explosions.
- Please strictly follow installation procedure when you want to disconnect AC or DC terminals.
- Please refer to "Installation" section of this manual for the details.
- Grounding instructions – this inverter must be connected to a permanently grounded wiring system. Ensure compliance with local requirements and regulations during installation.
- Never short-circuit the AC output or DC input. Do not connect the inverter to the mains if the DC input is short-circuited.

2. Product Introductions

This multi-functional inverter integrates an inverter, solar charger, and battery charger, providing uninterruptible power supply in a compact design. The LCD display allows users to configure and operate key functions easily, including battery charging, AC/solar charging, and input voltage settings for various applications.

2.1 Product Overview

IVPM8048P1G2-PRO/IVPM10048P1G2-PRO/IVPM12048P1G2-PRO:

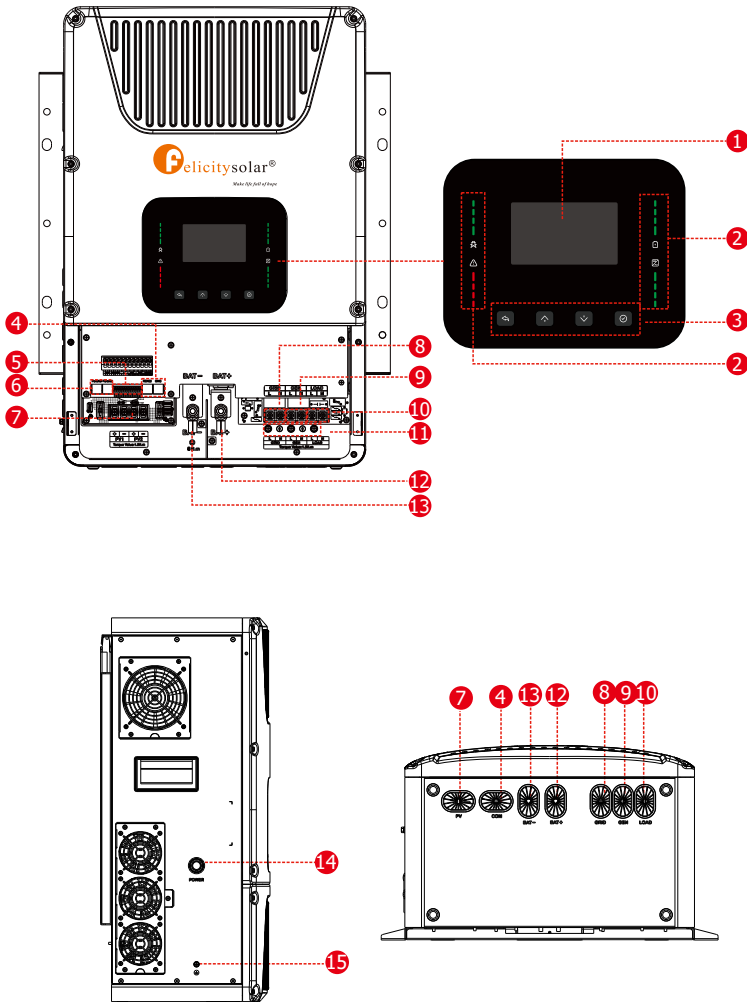

- | | | |
|------------------------|-----------------------------|----------------------------------|
| 1. LCD display | 6. Parallel port | 11. Ground of LOAD, GRID and GEN |
| 2. Inverter indicators | 7. PV input connection port | 12. BAT+ |
| 3. Function buttons | 8. Grid port | 13. BAT- |
| 4. Communication port | 9. Gen port | 14. Power ON/OFF button |
| 5. Function port | 10. Load port | 15. PE |

IVPM16048P1G2-PRO:

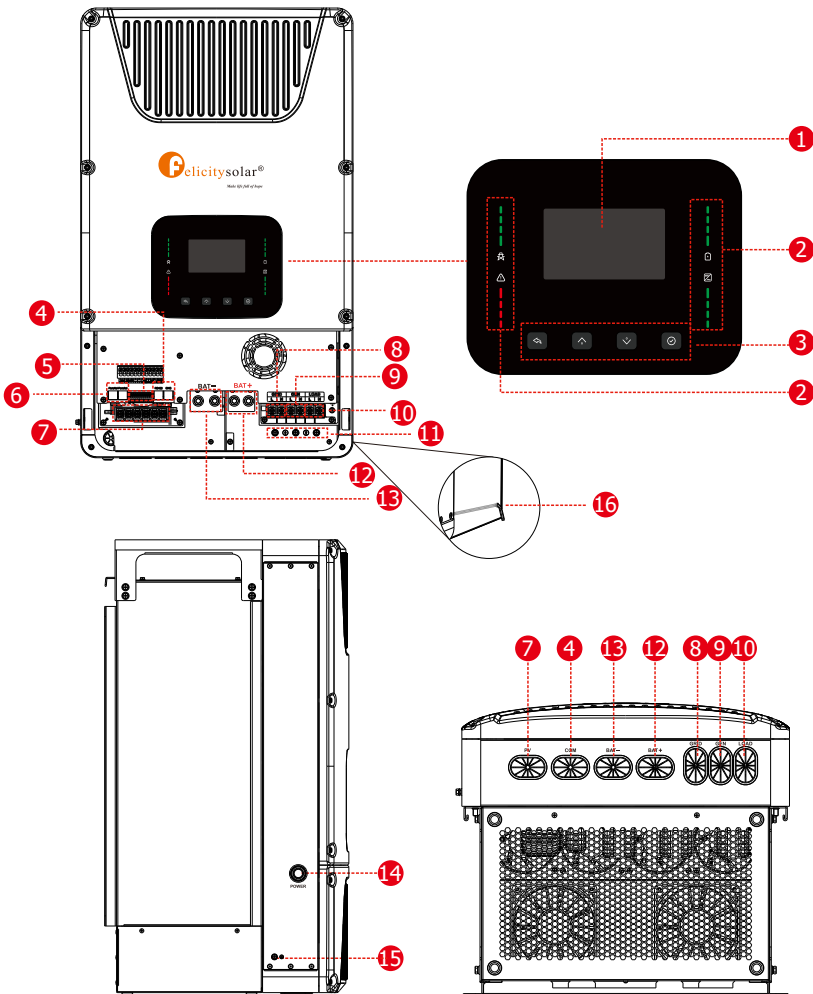

- | | | |
|------------------------|-----------------------------|----------------------------------|
| 1. LCD display | 6. Parallel port | 11. Ground of LOAD, GRID and GEN |
| 2. Inverter indicators | 7. PV input connection port | 12. BAT+ |
| 3. Function buttons | 8. Grid port | 13. BAT- |
| 4. Communication port | 9. Gen port | 14. Power ON/OFF button |
| 5. Function port | 10. Load port | 15. PE |
| 16. Tool Storage Hole | | |

2.2 Product Dimensions

IVPM8048P1G2-PRO/IVPM10048P1G2-PRO/IVPM12048P1G2-PRO:

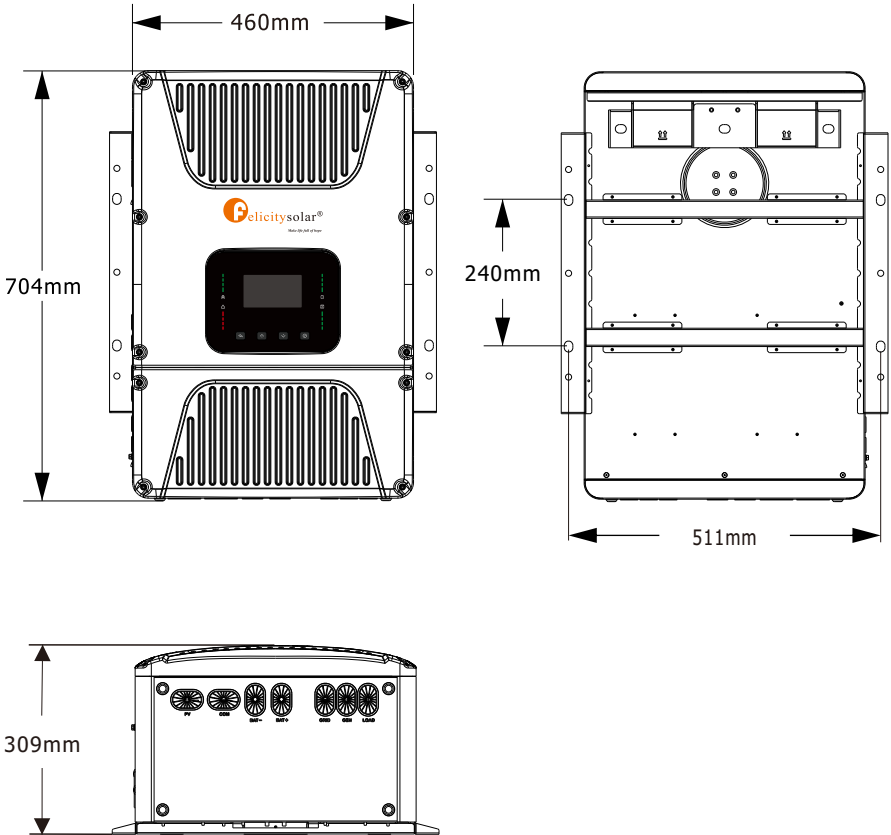

IVPM16048P1G2-PRO:

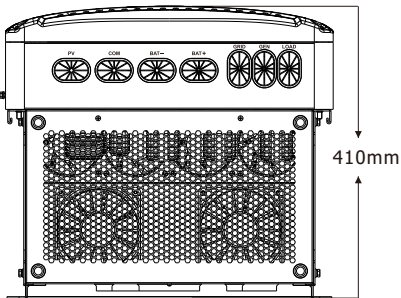
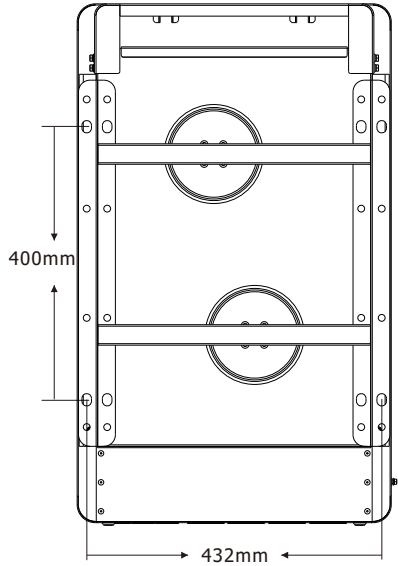
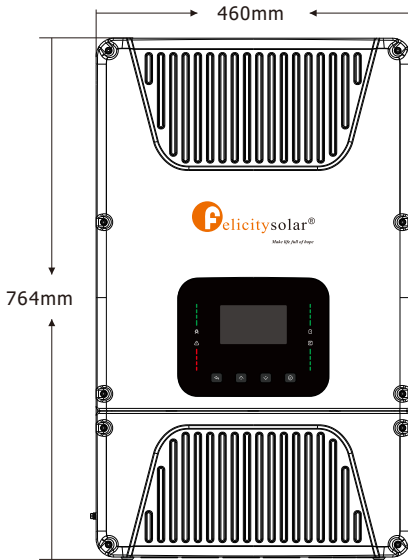

2.3 Product Features

- Self-consumption.
- Auto restart while AC is recovering.
- Programmable multiple operation modes: APL and UPS.
- Configurable battery charging current based on applications by LCD setting.
- Compatible with voltage power or generator power.
- Overload/overtemperature/short circuit protection.
- Supporting remote monitoring and build-in 2 strings of MPPT trackers.
- Application Mode: It includes three working modes: Backup Mode, Intelligent Mode, and Economic Mode.

2.4 Basic System Architecture

- The following illustration shows basic application of this inverter.
- It also includes following devices to have a Complete running system.
- Generator or Utility
- PV modules
- Consult with your system integrator for other possible system architectures depending on your requirements.
- This inverter can power all kinds of appliances in home or office environment, including motor type appliances such as refrigerator and air conditioner.

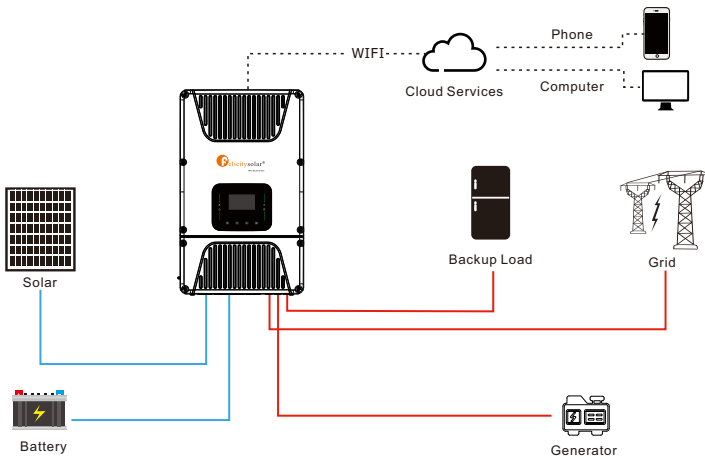















Note: When using the GEN port as the "generator input" port, the relays on the grid port and GEN port of the inverter will not be closed simultaneously. The relays on the GEN port will only be closed when the inverter is running in off-grid mode.

3. Installation

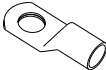
3.1 Parts List

Check the equipment before installation. Please make sure nothing is damaged in the package. You should have received the items in the following package:

 Inverter × 1	 User Manual × 1	 Quick Installation Guide × 1	 Warranty Card × 1
 Expansion Screw × 7	 OT Terminals × 10	 OT Terminals 16K: × 6 / 8K & 10K & 12K: × 4	 Parallel Communication Cable × 1
 Mounting Hole Template × 1	 Wall Mount Bracket × 1	 SC-shaped Terminal 16K: × 4 / 8K & 10K & 12K: × 2	 Hex Wrench × 1
 PARA Connector × 1	 NTC × 1	 BMS Communication Cable × 1	

NO.	Name	Description	Quantity
1	Inverter	Inverter	1
2	User Manual	User manual	1
3	Quick Installation Guide	Quick Installation Guide	1
4	Warranty Card	Warranty card	1
5	Expansion Screw	Used for securing the product's wall mount	7
6	OT Terminals	Used for external grounding, AC input, AC output, and generator connection	10
7	OT Terminals	Used for PV connection	6(16K) 4(8K&10K&12K)
8	Parallel Communication Cable	Used for multiple parallel machine communication	1
9	Mounting Hole Template	Use to assist the position of wall hangers	1
10	Wall Mount Bracket	Used to fix the inverter to the wall	1
11	SC-shaped terminal	For battery connection	4(16K) 2(8K&10K&12K)
12	Hex Wrench	For assisting in front cover removal	1
13	PARA Connector	Used for multiple parallel machine communication	1
14	NTC	Battery temperature sensor	1
15	BMS Communication Cable	For BMS communication with the battery pack	1

3.2 Product handling requirements

Lift the inverter out of the packing box and transport it to the designated installation location.

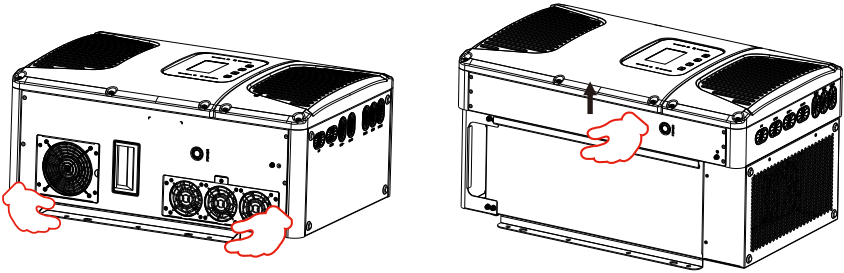

CAUTION:

- Improper handling may cause personal injury!
- Arrange an appropriate number of personnel to carry the inverter according to its weight. Installation personnel should wear protective equipment such as anti-impact shoes and gloves.
- Placing the inverter directly on a hard surface may damage its metal enclosure. Protective materials such as sponge pads or foam cushions should be placed underneath.
- Move the inverter by one or two persons, or use an appropriate transport tool.
- Lift the inverter using the provided handles. Do not move it by holding the terminals.
- Keep the battery away from water and fire.

3.3 Mounting instructions

Installation Precaution

This inverter is designed for indoor use. Please ensure the installation site meets the following conditions:





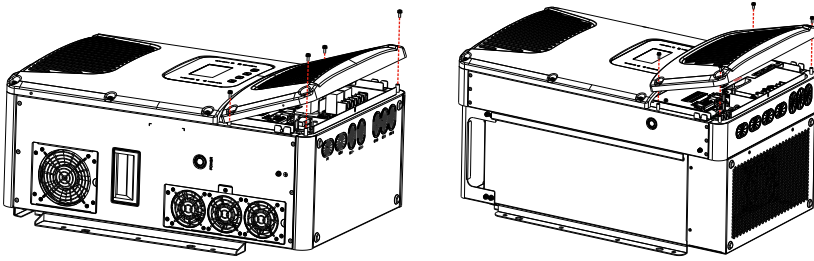















- Avoid direct sunlight.
- Avoid areas where highly flammable materials are stored.
- Avoid potentially explosive areas.
- Avoid direct exposure to cold air.
- Do not install near television antennas or antenna cables.
- Do not install at altitudes exceeding approximately 2000 meters above sea level.
- Avoid environments with precipitation or humidity levels above 95%.

Avoid direct sunlight, rain exposure, or snow accumulation during installation and operation. Before connecting the wires, remove the wiring cover by unscrewing the screws as shown below.



Installations Tools

Refer to the following recommended installation tools. Other auxiliary tools may also be used as needed.

 Safety Gloves	 Earplugs	 Safety Goggles	 Anti-dust respirator	 Safety shoes
 Marking pen	 socket wrenches set	 Screwdriver	 Hammer	 anti-static wrist strap
 Cleaner	 Utility Knife	 linesman pliers	 Wire cutter	 Wire stripper
 Crimping tool 4-6mm ²	 Hydraulic pliers	 Level	 Measuring tape	 Percussion drill

Considering the following points before selecting where to install:

- Select a vertical wall with sufficient load-bearing capacity, preferably made of concrete or other non-flammable material. The installation example is shown below.
- Install this inverter at eye level in order to allow the LCD display to be read at all times.
- The ambient temperature is recommended to be between $-10\sim 55^{\circ}\text{C}$ to ensure optimal operation.
- Be sure to keep other objects and surfaces as shown in the diagram to guarantee sufficient heat dissipation and have enough space for removing wires on site.

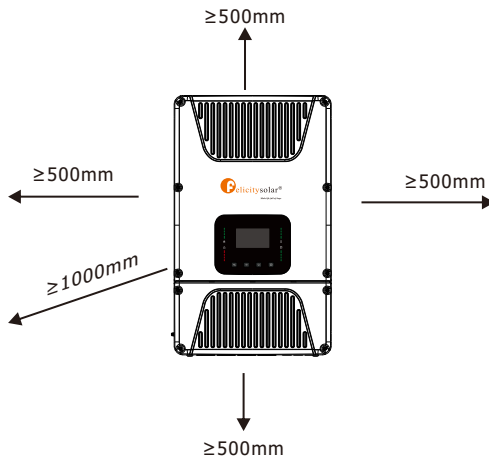

For proper air circulation to dissipate heat, allow a clearance of approx. 50cm to the side and approx. 50cm above and below the unit. And 100cm to the front.

Mounting the inverter

Please note that this inverter is heavy. Exercise caution when removing it from the packaging.

1. Position the inverter at the pre-planned wall-mounted installation site. Use a marker to mark the required drilling positions through the hinge openings.
2. Using an 10mm drill bit, drill 7 holes at the marked positions, each to a depth of 80mm.
3. Drive the expansion bolts into the holes with a suitable hammer, then remove the bolt rods.
4. Lift and move the inverter to align its hinge holes with the expansion bolts. Tighten the bolt rods securely to complete the installation.

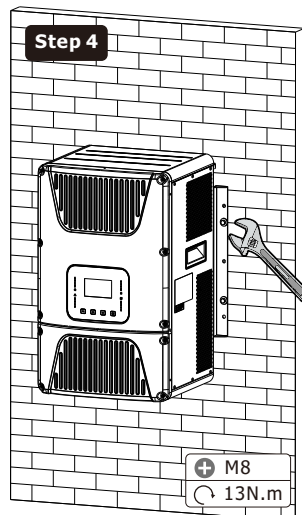
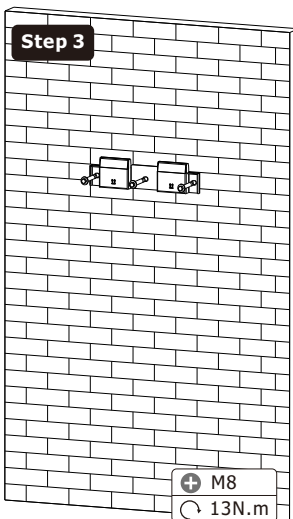
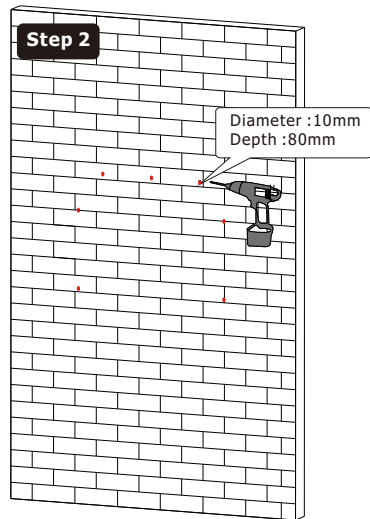
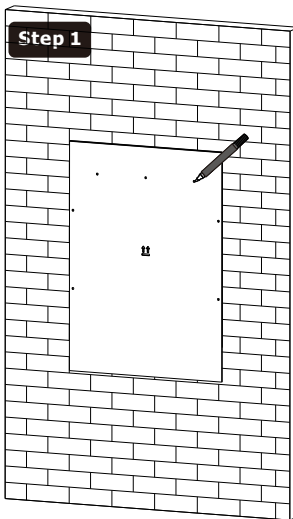

3.4 Battery connection

For safe operation and compliance, a separate DC over-current protector or disconnect device is required between the battery and the inverter. In some applications, switching devices may not be required but over-current protectors are still required. Refer to the typical amperage in the table below for the required fuse or circuit breaker size.

Model	Wire Size	Cable(mm ²)	Torque value(max)
IVPM8048P1G2-PRO	1AWG	40	8N.m
IVPM10048P1G2-PRO IVPM12048P1G2-PRO	2/0AWG	70	8N.m
IVPM16048P1G2-PRO	2*2/0AWG	2*70	8N.m



All wiring must be performed by a professional person.
 Connecting the battery with a suitable cable is important for safe and efficient operation of the system.

Please follow below steps to implement battery connection:

1. Select the recommended wire size and then use wire strippers to remove about 18mm of the insulation from the wire. Connect the prepared wire to the OT terminal (see the attached parts list for details ①), and use a crimping tool to press the components tightly together. Make sure there is no wear or breakage of the wire strands (worn strands may cause fine copper wires to be exposed), and be careful to prevent the wire strands from spreading apart, otherwise it may cause fine strands to be exposed and result in a short circuit.

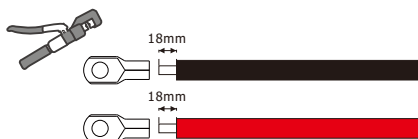

2. Insert the wires according to the marks on the terminal blocks and tighten the nuts with the recommended torque.

3. Make sure polarity at both the battery and inverter is correctly connected.

IVPM8048P1G2-PRO/IVPM10048P1G2-PRO/IVPM12048P1G2-PRO:

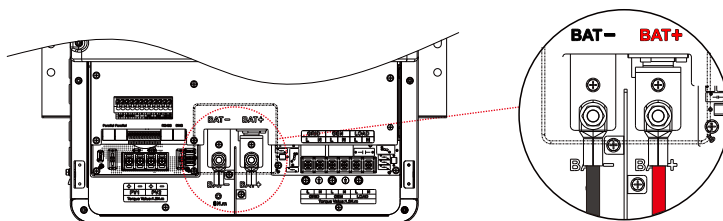

IVPM16048P1G2-PRO:

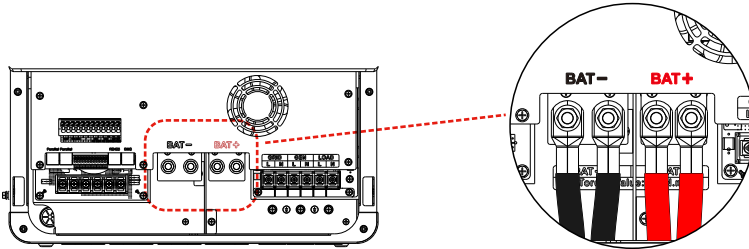

- Installation must be performed with care.
- Before making the final DC connection or closing the DC breaker/disconnector, ensure the positive (+) terminal is connected to positive (+) and the negative (-) terminal is connected to negative (-). Reversed battery polarity will damage the inverter.

3.4.1 Function port definition

IVPM8048P1G2-PRO/IVPM10048P1G2-PRO/IVPM12048P1G2-PRO:

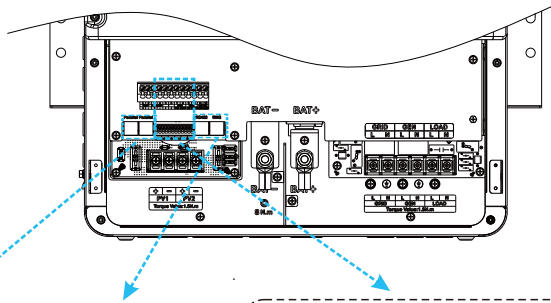

ParallelParallel



RS485 BMS



- Parallel Port 1: Parallel Communication Interface 1.
- Parallel Port 2: Parallel Communication Interface 2.
- BMS: Used for battery communication.
- RS485: Host Computer Interface.

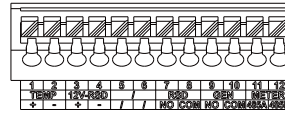

- **TEMP (Pins 1 & 2):** External NTC(Negative Temperature Coefficient thermistor), a battery temperature sensor for lead-acid batteries.
- **12V-RSD (Pins 3 & 4):** Provide a 12V power supply for the Rapid shutdown device.
- **RSD (Pins 7 & 8):** Rapid shutdown device for connecting the DC side string of the photovoltaic system
- **GEN (Pins 9 & 10):** Under the condition of the device being powered on and AC input being present, Pins 9 and 10 are normally open by default. When the AC input is disconnected, Pins 9 and 10 are closed. This can be used for the automatic generator start function.
- **METER (Pins 11 & 12):** For energy meter communication

IVPM16048P1G2-PRO:

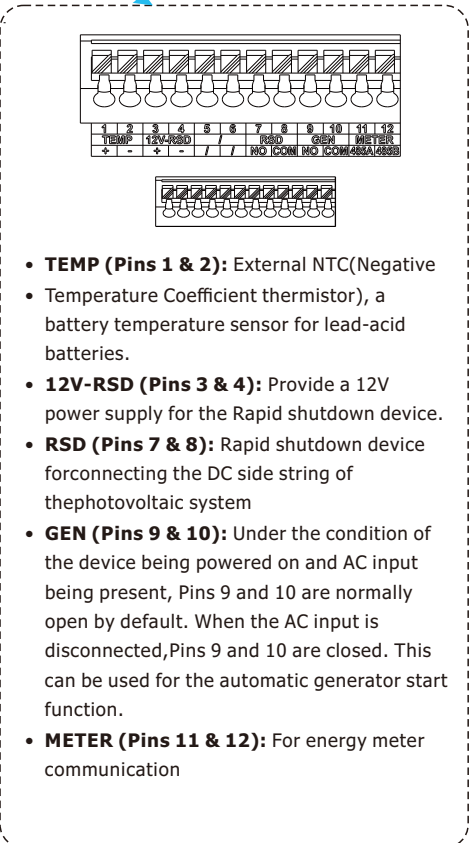
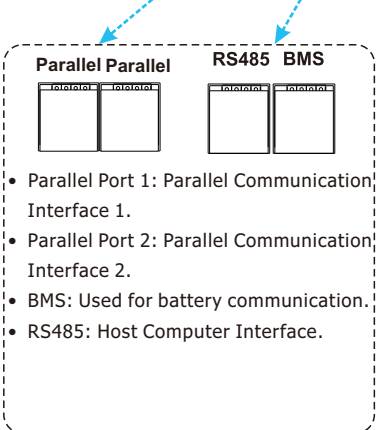
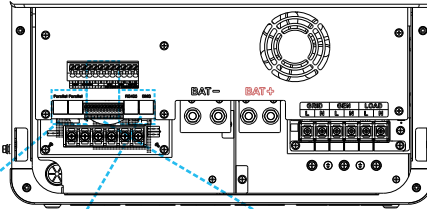

**3.4.2 Temperature sensor connection for lead-acid battery
 IVPM8048P1G2-PRO/IVPM10048P1G2-PRO/IVPM12048P1G2-PRO:**

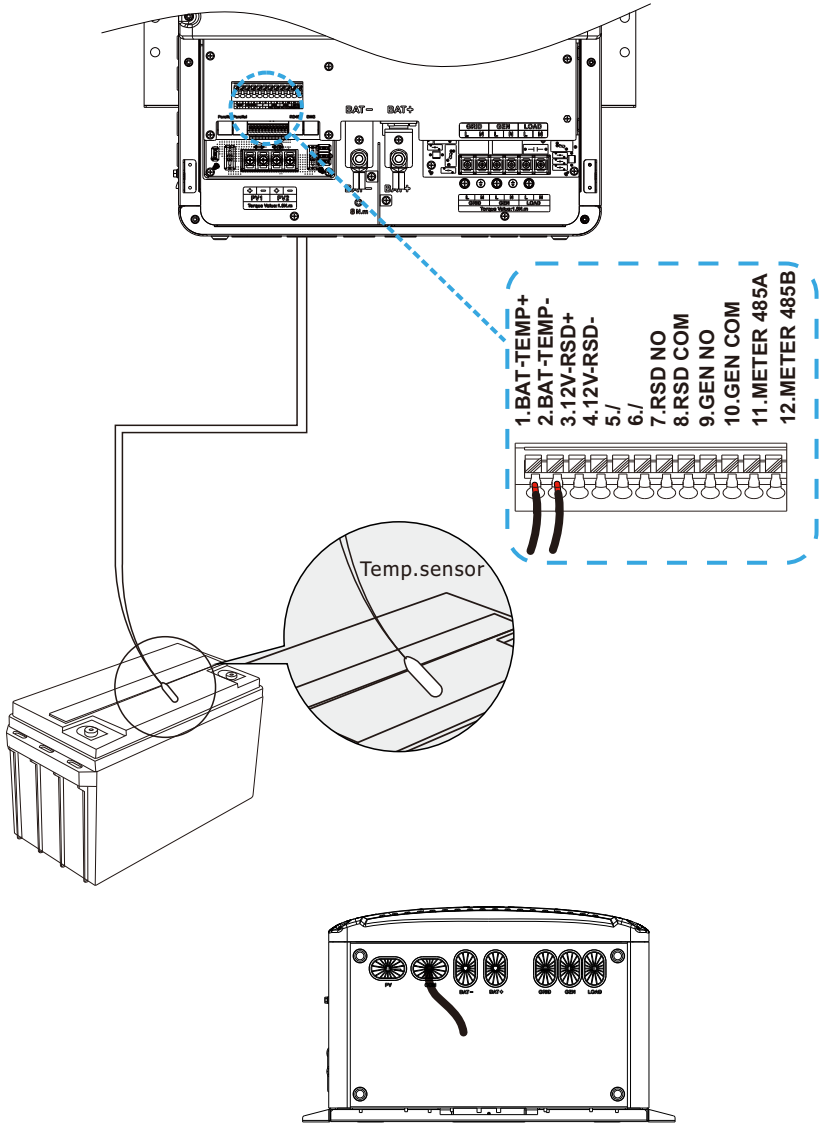

IVPM16048P1G2-PRO:

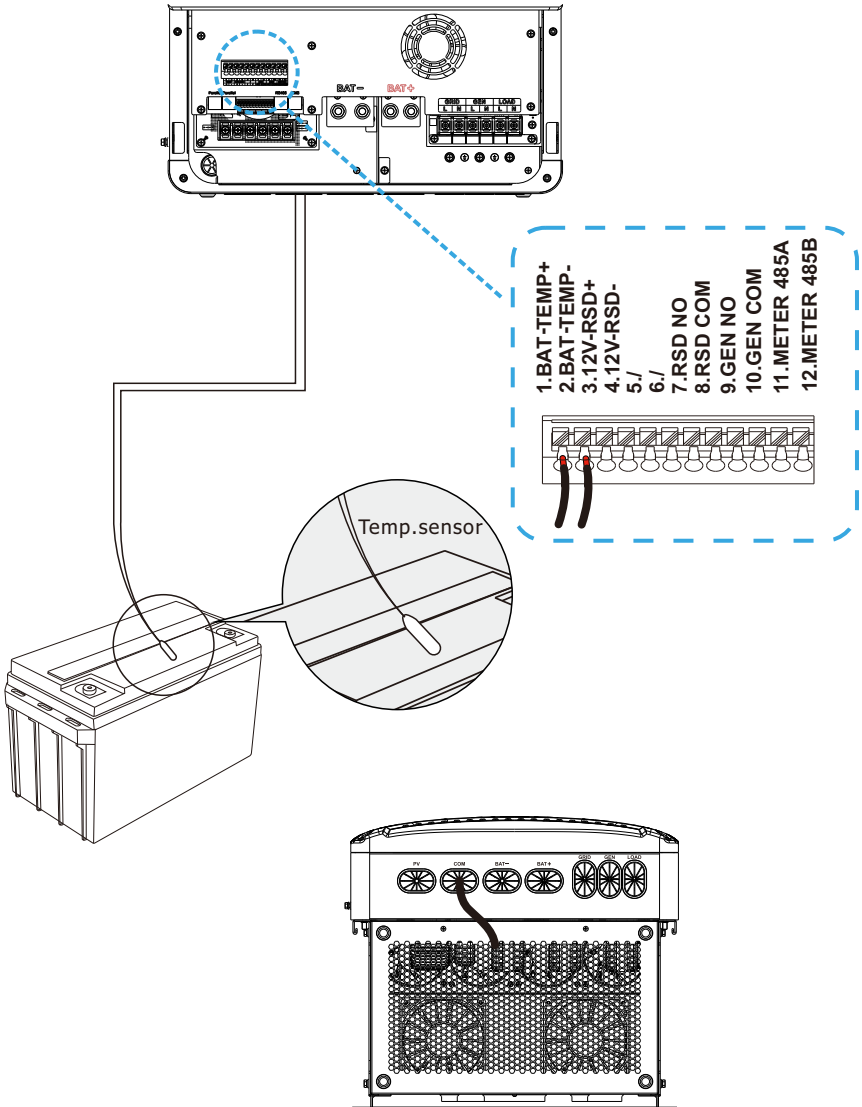

3.5 Grid connection and backup load connection

- Before connecting to the grid, a separate AC breaker must be installed between the inverter and the grid, and also between the backup load and the inverter. This will ensure the inverter can be securely disconnected during maintenance and fully protected from over current. For the 15kW model, the recommended AC breaker for backup load is 100A. For the 16 kW model, the recommended AC breaker for grid is 100A.
- There are three terminal blocks labeled "GRID," "LOAD," and "GEN." Do not connect input and output terminals incorrectly.



Note:

- In final installation, breaker certified according to IEC 60947-1 and IEC 60947-2 shall be installed with the equipment.
- All wiring must be performed by a qualified personnel. It is very important for system safety and efficient operation to use appropriate cable for AC input connection. To reduce risk of injury, please use the proper recommended cable as below.
- First connect the ground wire, then connect the L and N wires.

Grid connection, ground connection and backup load connection (Copper wires)

Model	Wire Size	Cable(mm ²)	Torque value(max)
IVPM8048P1G2-PRO IVPM10048P1G2-PRO IVPM12048P1G2-PRO IVPM16048P1G2-PRO	5AWG	16	1.5N.m

Please follow below steps to implement AC input/output connection:

1. Prior to making connections to the Grid, Load, and Gen ports, ensure the AC circuit breaker or disconnecter is switched off.
2. Select the recommended wire size and then use wire strippers to remove about 12mm of the insulation from the wire. Connect the prepared wire to the OT terminal (see the attached parts list for details ⑥), and use a crimping tool to press the components tightly together. Make sure there is no wear or breakage of the wire strands (worn strands may cause fine copper wires to be exposed), and be careful to prevent the wire strands from spreading apart, otherwise it may cause fine strands to be exposed and result in a short circuit.

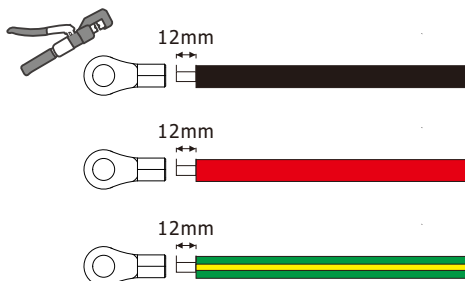

IVPM8048P1G2-PRO/IVPM10048P1G2-PRO/IVPM12048P1G2-PRO:

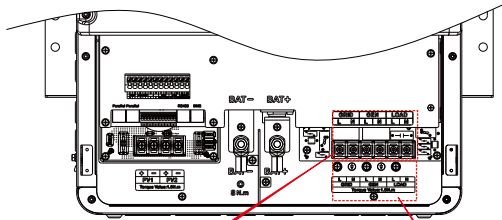

GRID		GEN		LOAD	
L	N	L	N	L	N

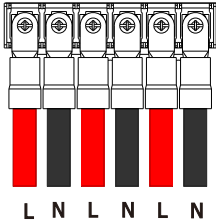

Ground of LOAD, GRID and GEN

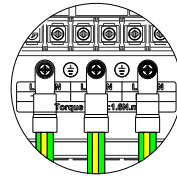

IVPM16048P1G2-PRO:

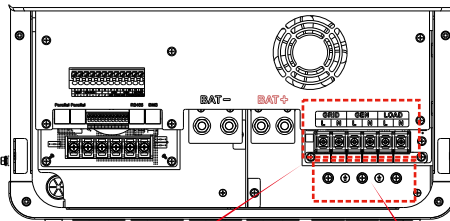

GRID		GEN		LOAD	
L	N	L	N	L	N

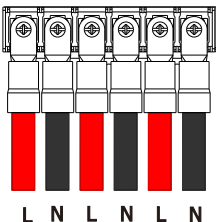

Ground of LOAD, GRID and GEN

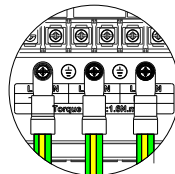



Ensure the AC power source is disconnected before wiring the unit. Prioritize connecting the ground wire first.

3. Insert the wires according to the marks on the terminal blocks and tighten the screws to the recommended torque to ensure that the corresponding L, N and PE wires are connected to the corresponding terminals.

4. Appliances such as air conditioner are required at least 2-3 minutes to restart because it is required to have enough time to balance refrigerant gas inside of circuit. If a power shortage occurs and recovers in short time, it will cause damage to your connected appliances. To prevent this kind of damage, please check manufacturer of air conditioner if it is equipped with time-delay function before installation. Otherwise, this inverter will trigger overload fault and cut off output to protect your appliance but sometimes it still causes internal damage to the air conditioner.

3.6 PV Connection

Before connecting PV modules, install a separate DC circuit breaker between the inverter and the PV modules. It is very important for system safety and efficient operation to use appropriate cable for PV module connection. To reduce the risk of injury, use the recommended cable size shown below.

Model	Wire Size	Cable(mm ²)	Torque value(max)
IVPM8048P1G2-PRO IVPM10048P1G2-PRO IVPM12048P1G2-PRO IVPM16048P1G2-PRO	10AWG	6	1.5N.m



To prevent malfunction, do not connect PV modules with potential current leakage to the inverter. For example, grounded PV modules will cause current leakage to the inverter. When using PV modules, please ensure the PV+ & PV- of solar panel is not connected to the system ground bar.



A PV junction box with surge protection must be used; otherwise, lightning strikes on PV modules may damage the inverter.

3.6.1 PV Module Selection:

When selecting proper PV modules, please be sure to consider below parameters:

- 1) Open circuit Voltage (Voc) of PV modules not exceeds max. PV array open circuit voltage of inverter.
- 2) Open circuit Voltage (Voc) of PV modules should be higher than min. start voltage.
- 3) The PV modules used to connected to this inverter shall be Class A rating certified according to IEC 61730.

Inverter Model	IVPM8048P1G2-PRO	IVPM10048P1G2-PRO IVPM12048P1G2-PRO	IVPM16048P1G2-PRO
PV Input Voltage	450V(100V~525V)		
MPPT Voltage Range	100V~450V		
No. of MPP Trackers	1	2	2
No. of Strings MPP Tracker	2	1+1	2+1

3.6.2 PV Module Wire Connection:

1. Switch the Grid Supply Main Switch(AC)OFF.
2. Switch the DC Isolator OFF.
3. Assemble PV input connector to the inverter.



Safety Hint:

- When using PV modules, please ensure the PV+ & PV- of solar panel is not connected to the system ground bar.
- Before connection, please make sure the polarity of the output voltage of PV array matches the "DC+" and "DC-" symbols.
- Before connecting inverter, please make sure the PV array open circuit



Safety Hint:

- Please use approved DC cable for PV system.voltage is within the 500V of the inverter.

The steps to assemble the DC connectors are listed as follows:

1. Select the recommended wire size and then use wire strippers to remove about 8.5mm of the insulation from the wire. Connect the prepared wire to the OT terminal (see the attached parts list for details ⑦), and use a crimping tool to press the components tightly together. Make sure there is no wear or breakage of the wire strands (worn strands may cause fine copper wires to be exposed), and be careful to prevent the wire strands from spreading apart, otherwise it may cause fine strands to be exposed and result in a short circuit.

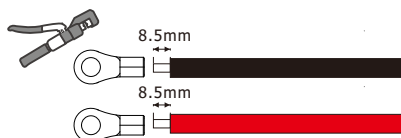

2. Insert the wires according to the markings on the terminal block and tighten the screws to the recommended torque. Make sure the polarity connection between the PV and the inverter is correct.

IVPM8048P1G2-PRO/IVPM10048P1G2-PRO/IVPM12048P1G2-PRO:

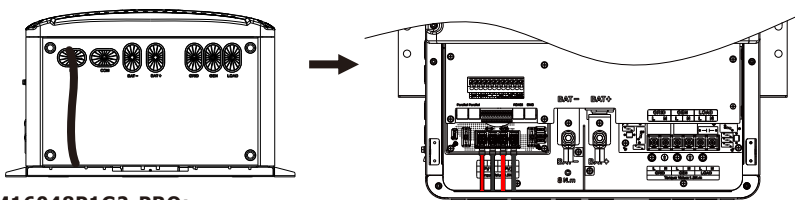

IVPM16048P1G2-PRO:

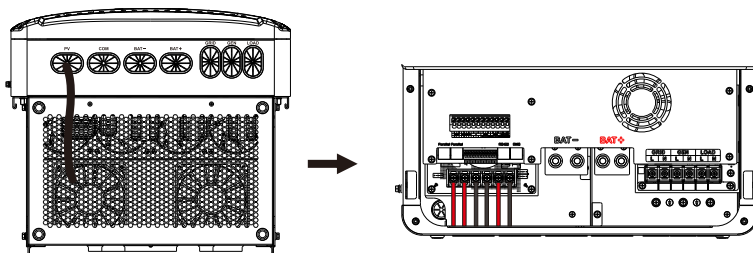



Warning:

Sunlight shines on the panel will generate voltage, high voltage in series may cause danger to life. Therefore, before connecting the DC input line, the solar panel needs to be blocked by the opaque material and the DC switch should be 'OFF', otherwise, the high voltage of the inverter may lead to life threatening conditions.

3.7 Earth Connection(mandatory)

Ground cable shall be connected to ground plate on grid side, this prevents electric shock if the original protective conductor fails.

IVPM8048P1G2-PRO/IVPM10048P1G2-PRO/IVPM12048P1G2-PRO:

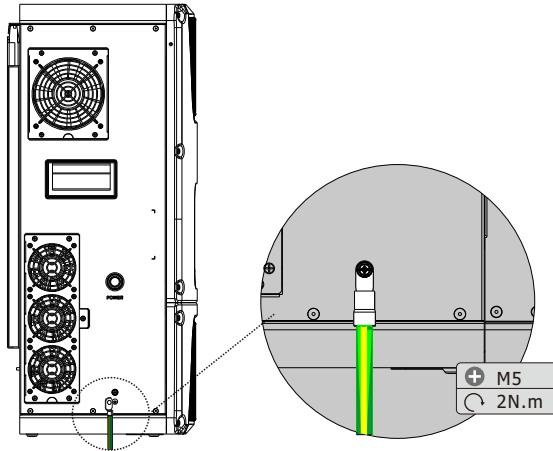

IVPM16048P1G2-PRO:

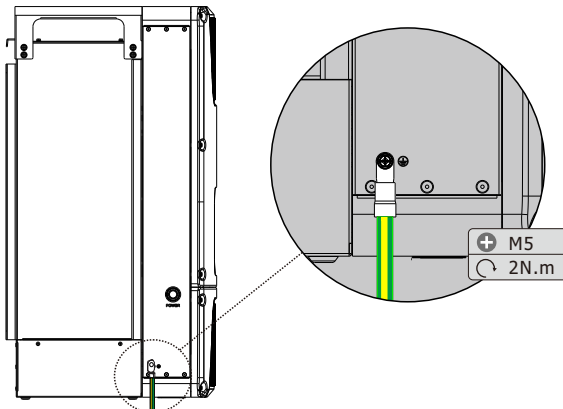

Earth connection (Copper wires)

Model	Wire Size	Cable(mm ²)	Torque Value(max)
IVPM8048P1G2-PRO IVPM10048P1G2-PRO IVPM12048P1G2-PRO IVPM16048P1G2-PRO	5AWG	16.0	2N.m

Earth connection (Copper wires) (Bypass)



Warning:

Inverter has built-in leakage current detection circuit, The type A RCD can be connected to the inverter for protection according to the local laws and regulations.

If an external leakage current protection device is connected, its operating current must be equal to 300 mA or higher, otherwise inverter may not work properly.

3.8 WIFI Connection

For application methods, please refer to the APP manual.

3.9 Wiring System for Inverter

This diagram is an example for grid systems without special requirements on electrical wiring connection.

Note: The load PE line and earthing bar must be grounded properly and effectively. Otherwise the back-up function may be abnormal when the grid fails.

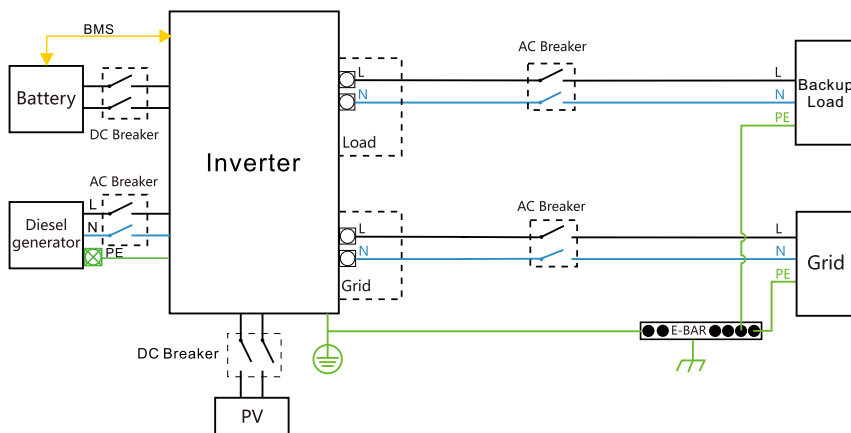

3.10 Typical application diagram of diesel generator

BMS
 Battery
 L wire
 N wire
 PE wire

GEN_OUT(3,4): dry contact signal for startup the diesel generator.

When the diesel generator is connected to the GEN port and "GEN Signal" is ticked, the open contact GEN_OUT will close (no voltage output) and serve as the dry contact signal for starting the diesel generator.

When the diesel generator is connected to the GRID port and "Grid Signal" is ticked, the open contact GEN_OUT will close (no voltage output) and serve as the dry contact signal for starting the diesel generator.

IVPM8048P1G2-PRO/IVPM10048P1G2-PRO/IVPM12048P1G2-PRO:

BMS
 Battery
 L wire
 N wire
 PE wire

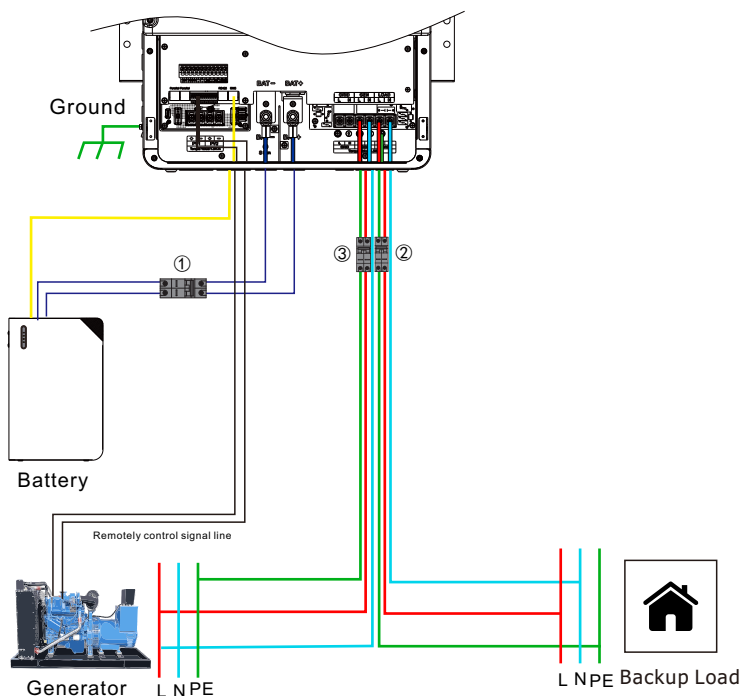

①DC Breaker for battery

IVPM8048P1G2-PRO:200A DC breaker

IVPM10048P1G2-PRO/IVPM12048P1G2-PRO:300A DC breaker

②AC Breaker for backup load port

IVPM8048P1G2-PRO/IVPM10048P1G2-PRO/IVPM12048P1G2-PRO:100A AC breaker

③AC Breaker for generator port

IVPM8048P1G2-PRO/IVPM10048P1G2-PRO/IVPM12048P1G2-PRO:100A AC breaker

IVPM16048P1G2-PRO:

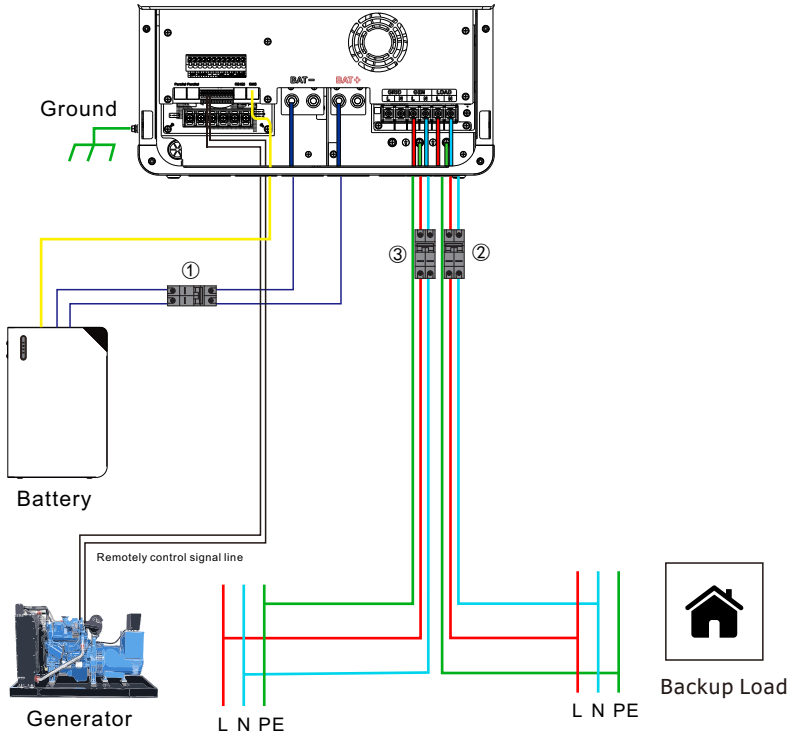

① DC Breaker for battery
 IVPM16048P1G2-PRO:400A DC breaker

② AC Breaker for backup load port
 IVPM16048P1G2-PRO:100A AC breaker

③ AC Breaker for generator port
 IVPM16048P1G2-PRO:100A AC breaker

3.11 Single phase parallel connection diagram

IVPM8048P1G2-PRO/IVPM10048P1G2-PRO/IVPM12048P1G2-PRO:

BMS
 Parallel
 Battery
 L wire
 N wire
 PE wire

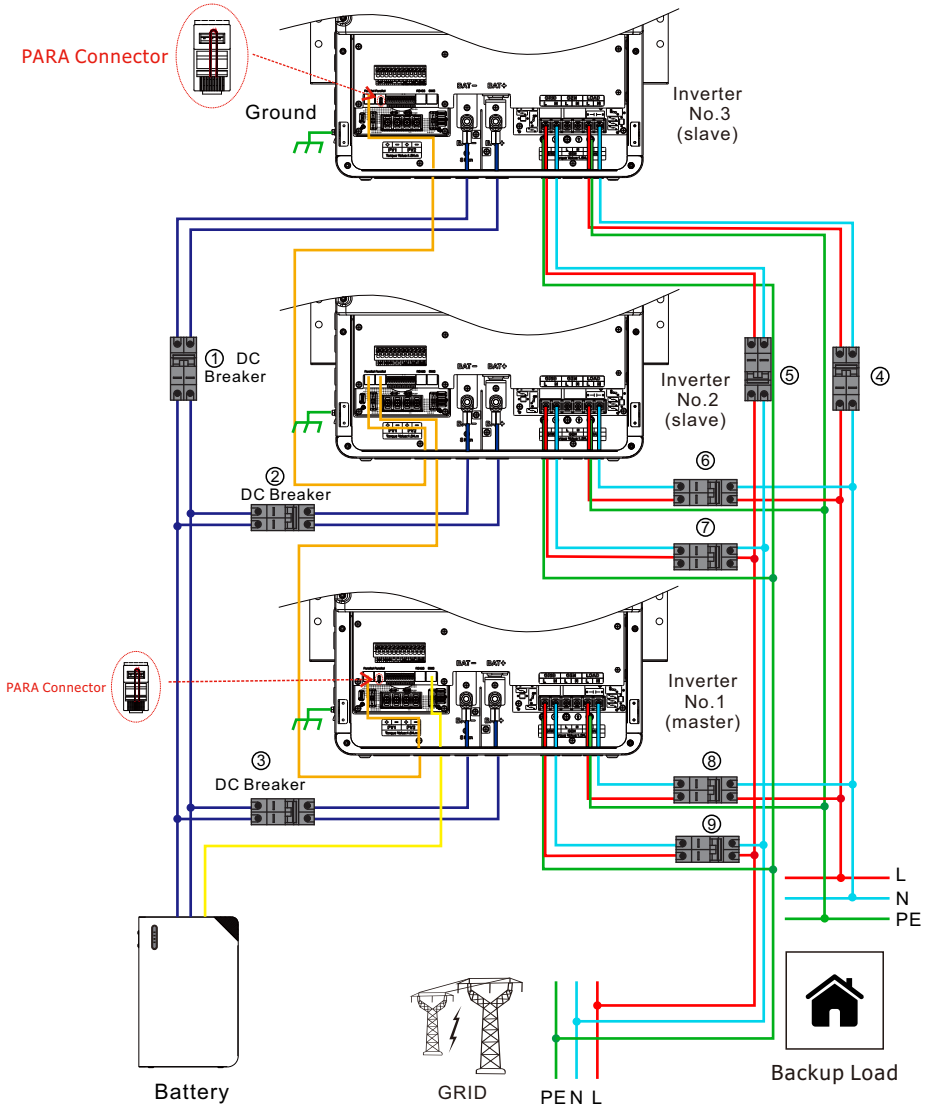

①②③DC Breaker for battery

IVPM8048P1G2-PRO:200A DC breaker

IVPM10048P1G2-PRO/IVPM12048P1G2-PRO:300A DC breaker

④⑥⑧ AC Breaker for backup load port

IVPM8048P1G2-PRO/IVPM10048P1G2-PRO/IVPM12048P1G2-PRO:100A AC breaker

⑤⑦⑨AC Breaker for grid port

IVPM8048P1G2-PRO/IVPM10048P1G2-PRO/IVPM12048P1G2-PRO:100A AC breaker

IVPM16048P1G2-PRO:

BMS
 Parallel
 Battery
 L wire
 N wire
 PE wire

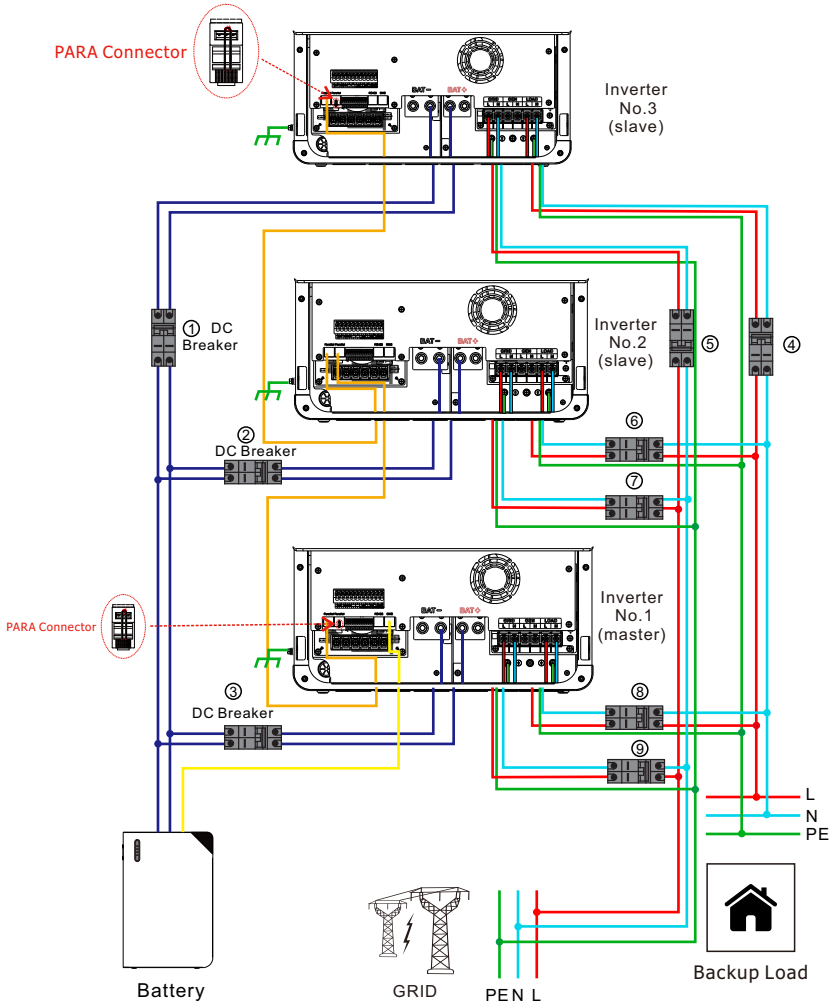

- ①②③ DC Breaker for battery
 IVPM16048P1G2-PRO:400A DC breaker
- ④⑥⑧ AC Breaker for backup load port
 IVPM16048P1G2-PRO:100A AC breaker
- ⑤⑦⑨ AC Breaker for grid port
 IVPM16048P1G2-PRO:100A AC breaker

3.12 Three phase Parallel Inverter

- ①②③ DC Breaker for battery
- IVPM8048P1G2-PRO/200A DC breaker
- IVPM10048P1G2-PRO/IVPM12048P1G2-PRO
- ④⑤ AC Breaker for backup load port
- IVPM8048P1G2-PRO/IVPM10048P1G2-PRO
- /IVPM12048P1G2-PRO:100A AC breaker

IVPM8048P1G2-PRO/IVPM10048P1G2-PRO/IVPM12048P1G2-PRO:

- BMS
- Parallel
- Battery
- L wire
- N wire
- PE wire

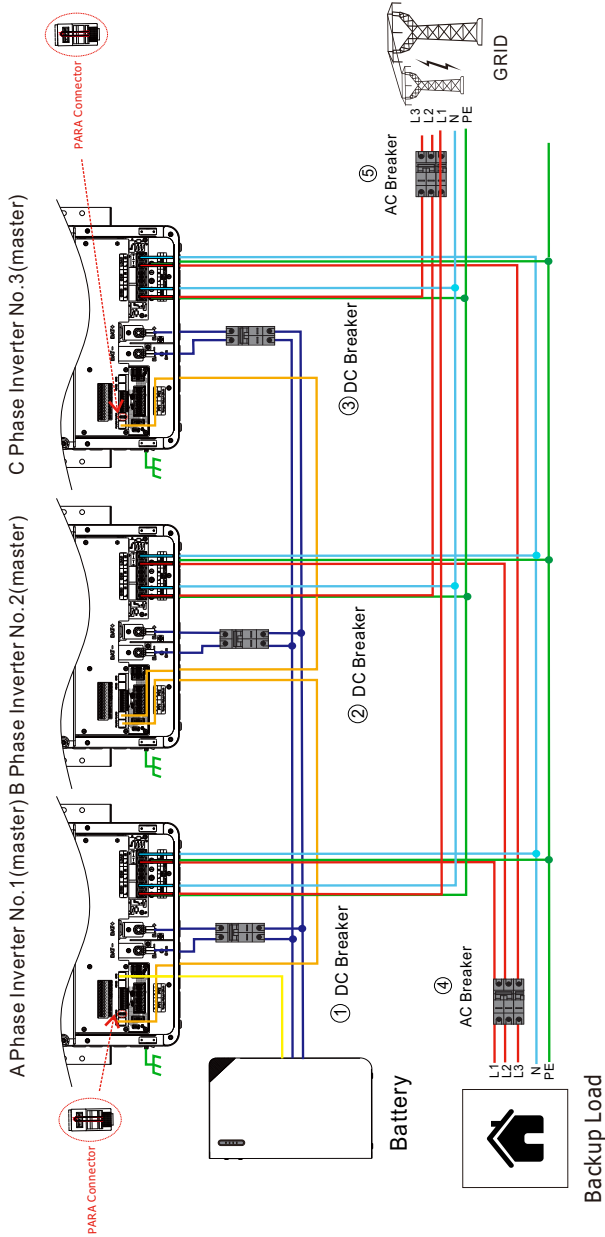

IVPM16048P1G2-PRO:

- ①②③DC Breaker for battery
- IVPM16048P1G2-PRO:400A DC breaker
- ④⑤ AC Breaker for backup load port
- IVPM16048P1G2-PRO:100A AC breaker

- BMS
- Parallel
- Battery
- L wire
- N wire
- PE wire

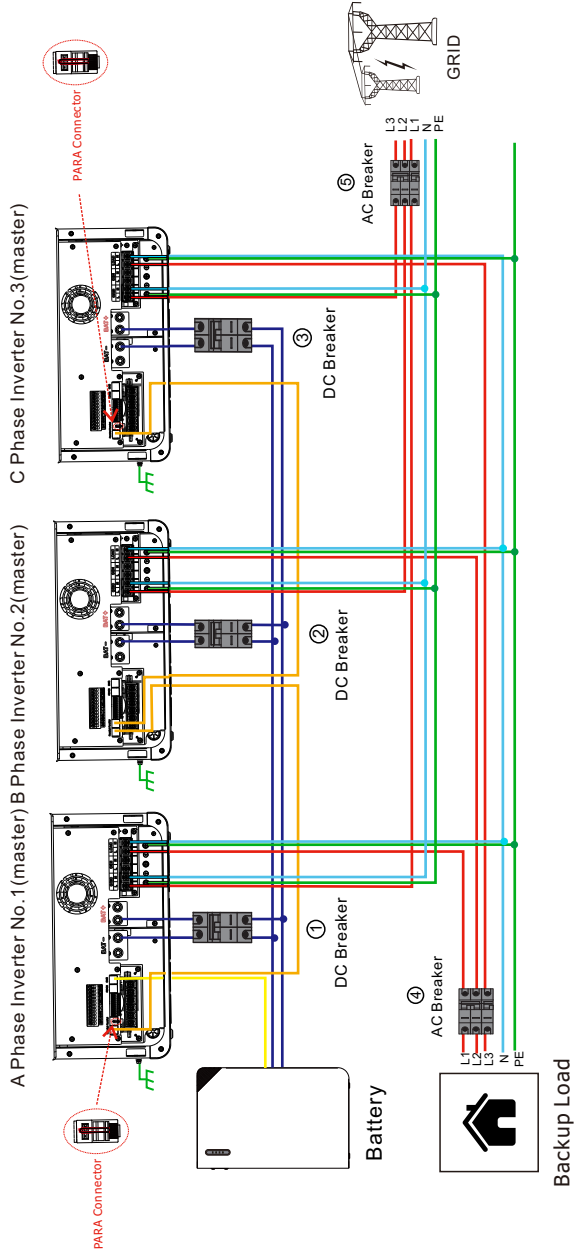

4. OPERATION

4.1 Power ON/OFF

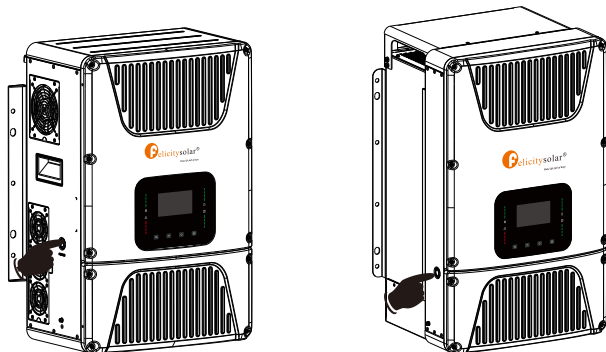

When at least one of the battery, PV, or power grid connections is normally connected:

Switch ON: Once the inverter is powered on, it will enter the working state and output power after a period of non-fault time

Note: When power grid is connected, even with the switch OFF, the inverter will still power on but without output (in this mode, inverter will output power and the power grid will charge the battery if the charging function is enabled in advanced settings).



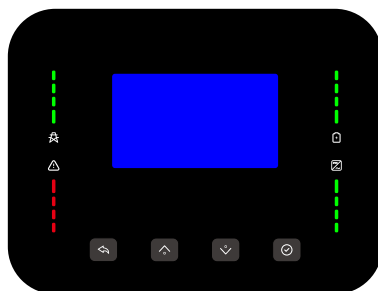

Switch OFF: The inverter is in standby mode without output. In standby mode without power grid connection, the inverter will automatically shut down after 3 minutes

4.2 Operation and Display Panel

The operation and display panel, shown in below chart, is on the front panel of the inverter. It includes three indicators, four function keys and a LCD display, indicating the operating status and input/output power information.



Function Key	Icon	Description
ESC		To exit setting mode
Up		To go to previous selection
Down		To go to next selection
Enter		To confirm the selection

LED Indicator	Icon	Color	State	Description
Battery		Green	solid	The battery is full.
			flashing	The battery is charging.
			dim	The battery is not charged.
Utility		Green	solid	Inverter is running in utility mode.
			dim	Inverter is not running in utility mode.
Inverter		Green	solid	Inverter is running in off-grid mode.
			dim	Inverter is not running in off-grid mode.
Fault		Red	solid	Inverter works in fault event.
			dim	Inverter works normally.
Buzzer Information				
Buzzer beep	When the buzzer is enabled, it will keep beeping if the inverter experiences a fault.			

5. LCD Display Icons

5.1 Boot Screen



After power-on, the system enters the boot screen and remains there for about 20 seconds while it completes the system initialization.

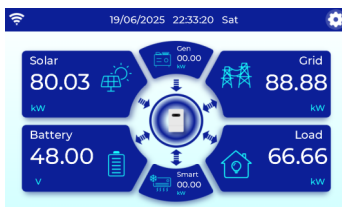

5.2 Main Screen

1. The LCD is a touchscreen, below screen shows the overall information of the inverter.



Operating status	Icon	Color	Description
Normal operation		Blue	The icon in the center of the home screen indicates that the system is in normal operation.
Fault		Red	If it turns into red, it means the inverter has fault
Warning		Yellow	If it turns into yellow, it means the inverter has warning

2. At the top of the screen is the time (year-month-day,time), and communication connection status.

- Ⓜ Parallel system master flag.
- Ⓢ Parallel system slave flag.
- 📶 WIFI communication success.

3. System setup icon, press this set button, you can enter into the system setup screen which including Basic Setup, Battery Setup, Grid Setup, Gen PORT Setup, Work Mode, Advanced Function, Parallel Setup, and History Fault.

The main screen includes the icons for PV (left up), grid (right up), battery (left bottom), load (right bottom), Smart Load (up), and GEN (bottom). It also displays the energy flow direction using arrows.

Some clarifications about the system status are as follows:

- PV power will always be positive.
- Grid power will always be positive.
- Load power will always be positive.
- Smart Load power will always be positive.
- GEN power will always be positive.

5.2.1 Power-on Instructions

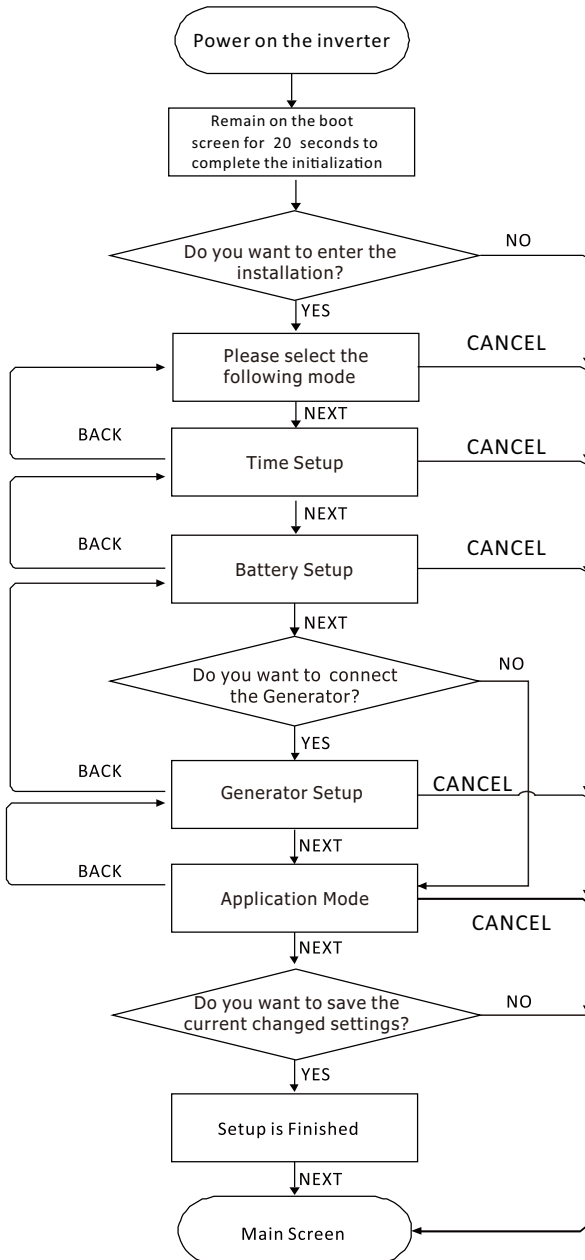

5.2.2 LCD operation flow chart

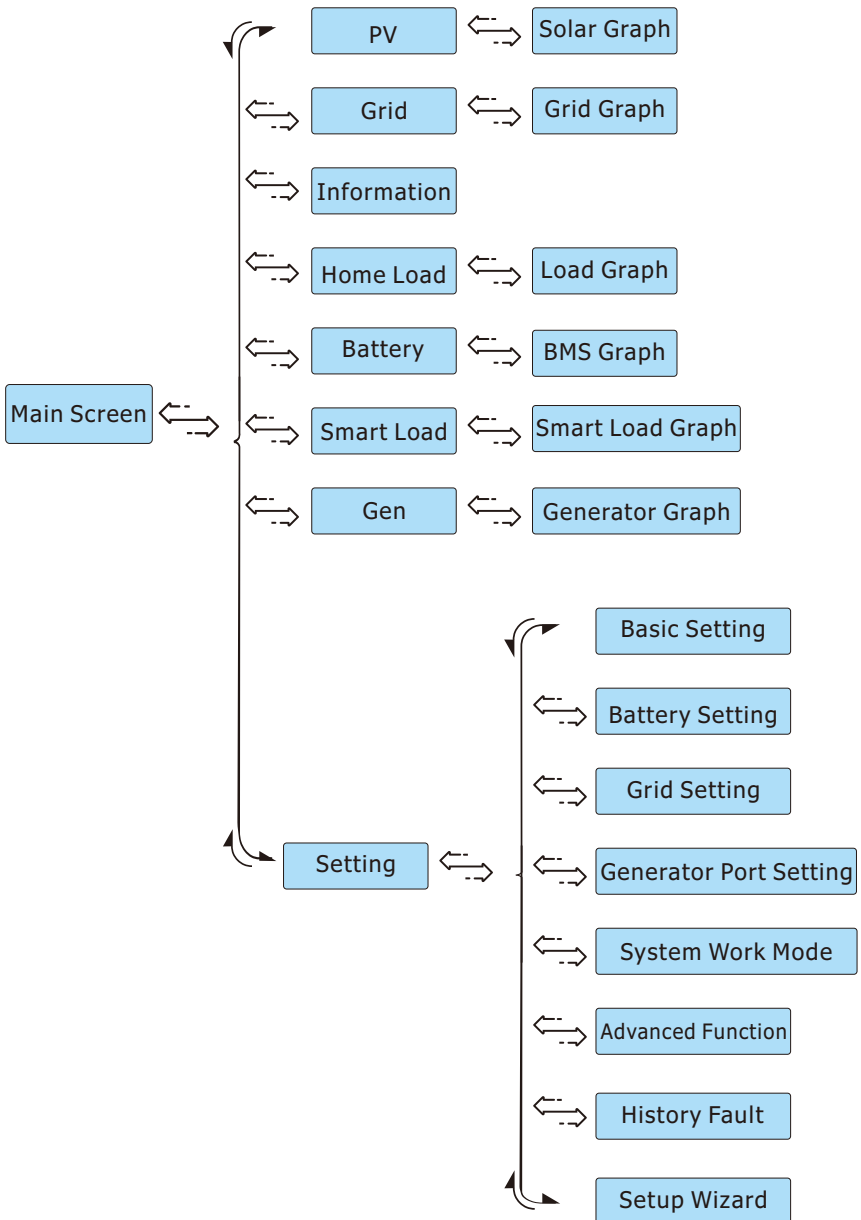

5.2.3 Setup Wizard Steps

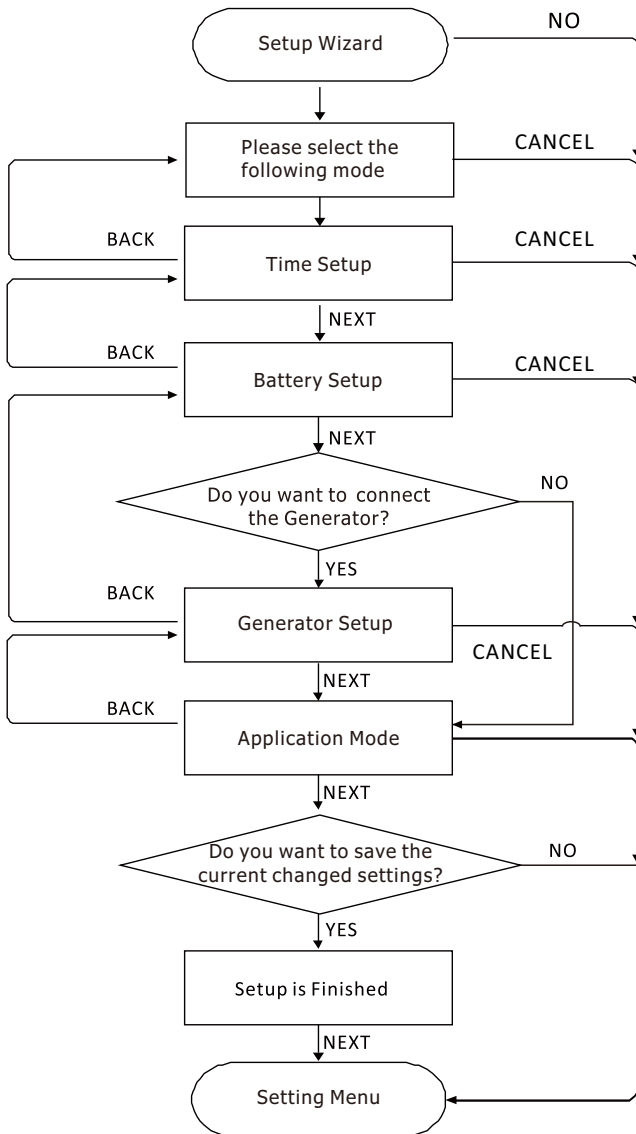

<div style="text-align: center; background-color: #e0f2f1; padding: 5px;">Generator</div> <p>Voltage: 0.0V Current: 0.0A Today=0.0kWh Power: 0.0kW Total=0.0kWh Frequency: 0.00Hz</p> <p style="text-align: left; margin-top: 10px;">Energy ↶</p>	<p>This is Generator detail page. Power: The power on the generator port at current time. Voltage: The AC voltage of phase to line on the generator port at current time. Current: The alternating current between the phase lines at the generator port at current time. Frequency: The AC frequency on the generator port at current time. Today/Total: Today's and total import energy from generator to the inverter. Energy: Press the "Energy" button will enter into the power curve page.</p>																														
<div style="text-align: center; background-color: #e0f2f1; padding: 5px;">Smart Load</div> <p>Power: 0kW Apparent Power: 0kVA Voltage: 0.0V Today=0.0kWh Current: 0.0A Total=0.0kWh Frequency: 0.0Hz</p> <p style="text-align: left; margin-top: 10px;">Energy ↶</p>	<p>This is the Smart Load Detail Page. Power: The active power of the smart load port at present. Apparent Power: The apparent power of the smart load port at present. Voltage: The output voltage of the smart load port at present. Current: The output current of the smart load port at present. Frequency: The frequency of the smart load port at present. Today/Total: Today's and total energy imported from the generator to the inverter. Energy: Press the "Energy" button will enter into the power curve page.</p>																														
<table border="1" style="width: 100%; border-collapse: collapse; text-align: center;"> <thead> <tr style="background-color: #0070c0; color: white;"> <th style="width: 33%;">PV1</th> <th style="width: 33%;">PV2</th> <th style="width: 33%;">Bat</th> </tr> </thead> <tbody> <tr><td>0.0kW</td><td>0.0kW</td><td>0.0V</td></tr> <tr><td>0.0V</td><td>0.0V</td><td>0.0kW</td></tr> <tr><td>0.0A</td><td>0.0A</td><td>0.0A</td></tr> <tr style="background-color: #0070c0; color: white;"> <th>Grid</th> <th>Inv</th> <th>Load</th> </tr> <tr><td>0.0kW</td><td>0.0kW</td><td>0.0kVA</td></tr> <tr><td>0Hz</td><td>0.0V</td><td>0.0kW</td></tr> <tr><td>0.0V</td><td>0.0A</td><td>0.0V</td></tr> <tr><td>0.0A</td><td>T-X:0°C</td><td>0.0A</td></tr> <tr><td></td><td>T-S:0°C</td><td></td></tr> </tbody> </table> <p style="text-align: right; margin-top: 10px;">↶</p>	PV1	PV2	Bat	0.0kW	0.0kW	0.0V	0.0V	0.0V	0.0kW	0.0A	0.0A	0.0A	Grid	Inv	Load	0.0kW	0.0kW	0.0kVA	0Hz	0.0V	0.0kW	0.0V	0.0A	0.0V	0.0A	T-X:0°C	0.0A		T-S:0°C		<p>This is INV detail page.</p>
PV1	PV2	Bat																													
0.0kW	0.0kW	0.0V																													
0.0V	0.0V	0.0kW																													
0.0A	0.0A	0.0A																													
Grid	Inv	Load																													
0.0kW	0.0kW	0.0kVA																													
0Hz	0.0V	0.0kW																													
0.0V	0.0A	0.0V																													
0.0A	T-X:0°C	0.0A																													
	T-S:0°C																														
<div style="text-align: center; background-color: #e0f2f1; padding: 5px;">Alarm Code</div> <table border="1" style="width: 100%; border-collapse: collapse; text-align: center;"> <thead> <tr style="background-color: #e0f2f1;"> <th>No</th> <th>Alarm Code</th> <th>Occurred time</th> </tr> </thead> <tbody> <tr><td style="height: 40px;"> </td><td> </td><td> </td></tr> </tbody> </table> <p style="font-size: small; margin-top: 5px;">Model: IVPM16048PIC2-PRO SN: I2345678901234567800 DSP Ver V8888-8888-9999 HMI Ver V11-0001 WIFI Ver V103</p> <p style="text-align: left; margin-top: 10px;">Invert ↶</p>	No	Alarm Code	Occurred time				<p>This is the Alarm Code Page. NO.: Displays the current alarm code. Alarm Code: Current fault name. Occurred Time: Fault occurrence time. Model: Equipment model. HMI Ver.: HMI (Human-Machine Interface) board software version. WIFI Ver.: WIFI software version. DSP Ver.: DSP (Digital Signal Processor) software version. SN: Inverter serial number.</p>																								
No	Alarm Code	Occurred time																													

5.4 Curve Page-Solar & Load & Grid & Generator & Smart Load

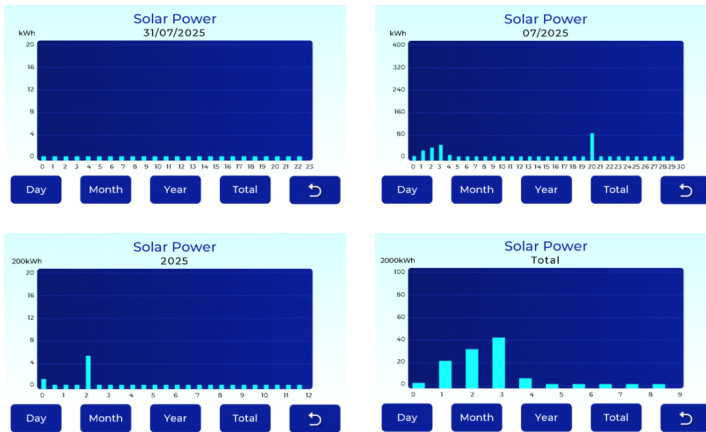

Solar power curve for daily, monthly, yearly and total can be roughly checked on the LCD, for more accuracy power generation, please check the web page or APP.

5.5 Setting Menu

Battery Setting	System Work Mode	Basic Setting	<p>This is Setting page,including seven items: Battery Setting,Advanced Function, Grid Setting, System Work Mode,Gen Setting, Basic Setting, History Fault Log, Setup Wizard.</p>
Grid Setting		Gen Setting	
Setup Wizard		Advanced Function	
		History Fault Log	
↻			

5.6 Battery Setting

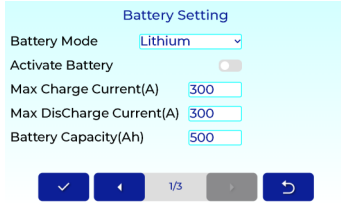

Battery Setting

Battery Mode: Lithium

Activate Battery:

Max Charge Current(A):

Max Discharge Current(A):

Battery Capacity(Ah):

Navigation: [Checkmark] [Back] 1/3 [Next] [Refresh]

Battery Type: including three options:
Lithium: Control the charging and discharging process of battery under the condition of the BMS of battery is communicating with the inverter.

User Defined: Control the charging and discharging process directly through battery voltage.

No Battery: Tick this item if no battery is connected to the system.

Activate battery: This feature will help recover a battery that is over discharged by slowly charging from the solar array or grid.

Max Charge Current: Max battery charging current

8KVA	10KVA	12KVA	16KVA
150A	205A	240A	300A

Max Discharge Current: Max battery discharging current

8KVA	10KVA	12KVA	16KVA
150A	205A	240A	300A

For AGM and Flooded, we recommend Ah battery size $\times 20\%$ = Charge/Discharge amps. For Lithium, we recommend Ah battery size $\times 50\%$ = Charge/Discharge amps. For Gel, follow manufacturer's instructions.

Battery Capacity: The total capacity of battery connected to this system, it can be used to calculate the SOC of battery bank under the "Batt SOC" mode

8KVA	10KVA	12KVA	16KVA
300Ah	350Ah	500Ah	500Ah

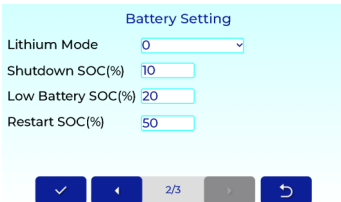

Battery Setting

Lithium Mode: 0

Shutdown SOC(%) :

Low Battery SOC(%) :

Restart SOC(%) :

Navigation: [Checkmark] [Back] 2/3 [Next] [Refresh]

When the "Lithium" mode is selected, the content on the "Battery Setting" page is shown as the figure on the left.

Lithium Mode: This is the BMS communication protocol code which can be confirmed on the "Approved Battery list" based on the battery model you are using.

Shutdown SOC: Be valid in off-grid mode, battery can discharge to this SOC, then the DC/AC inverter module of this inverter will be shut down and the solar power can only be used to charge the battery (Default: 10%).

Low Battery SOC: Be valid in on-grid mode, when the "Grid charge" has been checked, the battery SOC will remain above the set value of "Low Batt" (Default: 20%).

Restart SOC: Be valid in off-grid mode, after the DC/AC inverter module of this inverter is shut down, the PV power can only be used to charge the battery. After the battery SOC has resumed to this "Restart" value, the DC/AC inverter module will restart to output AC power (Default: 50%).

<div style="background-color: #e0f2f1; padding: 5px; text-align: center; font-weight: bold; font-size: 0.9em;">Battery Setting</div> <p>Absorption Volt(V) <input style="width: 80px;" type="text" value="57.6"/></p> <p>Float Volt(V) <input style="width: 80px;" type="text" value="55.2"/> Equalization Volt(V) <input style="width: 80px;" type="text" value="58.4"/></p> <p>Low Batt(V) <input style="width: 80px;" type="text" value="47.5"/> Equalization Days <input style="width: 80px;" type="text" value="90"/></p> <p>Shutdown(V) <input style="width: 80px;" type="text" value="42.0"/> Equalization Mins <input style="width: 80px;" type="text" value="60"/></p> <p>Restart(V) <input style="width: 80px;" type="text" value="46.0"/> TEMPCO(mV/C/Cell) <input style="width: 80px;" type="text" value="0"/></p> <div style="display: flex; justify-content: space-around; margin-top: 10px;"> ✓ ← 2/3 → </div>	<p>When the "User Defined" mode is selected, the content on the "Battery Setting" page is shown as the figure on the left.</p> <p>Three stage charging strategy for lead-acid and incompatible lithium battery.</p> <p>If you are not familiar with these parameters, please keep the default values.</p> <p>Absorption Volt: The charging voltage during absorption charging stage(Default:57.6V).</p> <p>Float Volt: The charging voltage during floating charging stage(Default:55.2V).</p> <p>Low Batt: Be valid in on-grid mode, when the "Grid charge" has been checked, the battery SOC/voltage will remain above the set value of "Low Batt"(Default:47.5V).</p> <p>Shutdown: Be valid in off-grid mode, when battery SOC/voltage drop to this value, then the DC/AC inverter module of this inverter will be shut down and the solar power can only be used to charge the battery(Default:42.0V).</p> <p>Restart: Be valid in off-grid mode, after the DC/AC inverter module of this inverter is shut down, the PV power can only be used to charge the battery. When the battery SOC has returned to this "Restart" value, the DC/AC inverter module will restart to output AC power(Default:46.0V).</p> <p>Equalization Volt: When charging multiple battery modules or cells in series, the set charging voltage to ensure that the voltage of each battery module or cell is equal after fully charged(Default:58.4V).</p> <p>Equalization Days: Time interval for conducting equalization charging(Default:90).</p> <p>Equalization Mins: The duration of each equalization charging(Default:60).</p> <p>TEMPCO: The coefficient by which the voltage of a battery varies with temperature(Default:0).</p>
----------------------------------------------------------------------------------------------------------------------------------------------------------------------------------------------------------------------------------------------------------------------------------------------------------------------------------------------------------------------------------------------------------------------------------------------------------------------------------------------------------------------------------------------------------------------------------------------------------------------------------------------------------------------------------------------------------------------------------------------------------------------------------------------------------------------------------------------------------------------------------------------------------------------------------------------------------------------------------------------------------------------------------------------------------------------------------------------------------------------------------------------------------------------------------------------------------------------------------------------------------------------------------------------------------------------------------	-----------------------------------------------------------------------------------------------------------------------------------------------------------------------------------------------------------------------------------------------------------------------------------------------------------------------------------------------------------------------------------------------------------------------------------------------------------------------------------------------------------------------------------------------------------------------------------------------------------------------------------------------------------------------------------------------------------------------------------------------------------------------------------------------------------------------------------------------------------------------------------------------------------------------------------------------------------------------------------------------------------------------------------------------------------------------------------------------------------------------------------------------------------------------------------------------------------------------------------------------------------------------------------------------------------------------------------------------------------------------------------------------------------------------------------------------------------------------------------------------------------------------------------------------------------------------------------------------------------------------------------------------------------------------------------------------------------------------------------------------------------------------------------------

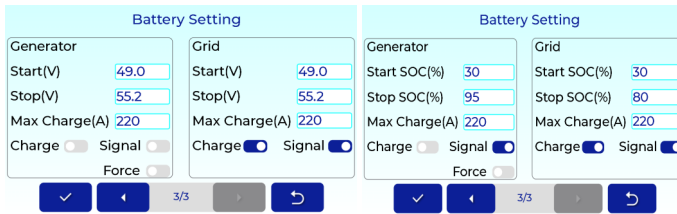

The parameters on left row are valid when it's going to use AC power from the GEN port to charge the battery.

The parameters on right row are valid when it's going to use AC power from the Grid port to charge the battery.

Generator

Start: When battery SOC or voltage drops to this set value, the inverter will auto start charge the battery from the GEN port(Default:30%SOC or 49.0V).

Stop: When the battery SOC or voltage reaches this set value, the inverter will end charge the battery from the GEN port(Default:95%SOC or 55.2V).

Max Charge: The maximum charging current allowed when only use AC power from the GEN port to charge the battery

8KVA	10KVA	12KVA	16KVA
120A	150A	170A	220A

Charge: Use the AC input power of GEN port to charge the battery.

Signal: When conditions are sufficient, the inverter will close or open the normally open relay used to control the start and stop of the generator.

Force: When the generator is connected, it is forced to start the generator without meeting other conditions.

Grid

Start: When battery SOC or voltage drops to this set value, the inverter will auto start charge the battery from the grid port(Default:30%SOC or 49.0V).

Stop: When the battery SOC or voltage reaches this set value, the inverter will end charge the battery from the grid port(Default:80%SOC or 55.2V).

Max Charge: The maximum charging current allowed when only use AC power from the grid port to charge the battery

8KVA	10KVA	12KVA	16KVA
120A	150A	170A	220A

Charge: It's allowed to absorb AC power from the grid port to charge the battery.

Signal: When a generator is connected to the grid port of inverter, this "Grid signal" can be

5.7 Grid Setting

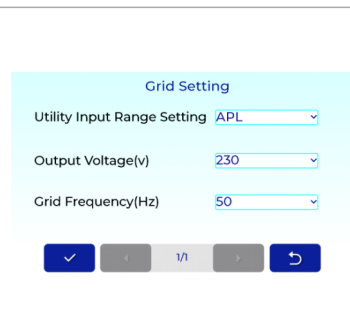



Utility Input Range Setting:Set grid input voltage range, optional: APL, UPS(Default: APL).It can only be set in standby mode.

Output Voltage:Set the rated output voltage of the inverter, optional:220V,230V,240V.(Default:230V).

Grid Frequency:Set according to the grid frequency in on-grid mode or frequency required by load in off-grid mode, optional:50Hz,60Hz (Default:50Hz).

5.8 Setup Wizard

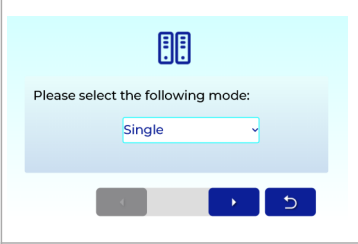
Click “” to return to the previous setting, “” to proceed to the next setting, or “” to exit setup and go to the Setting Menu.

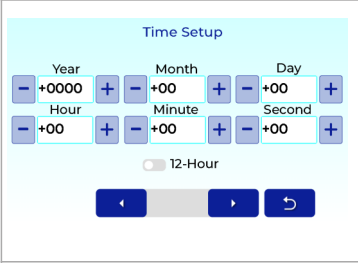
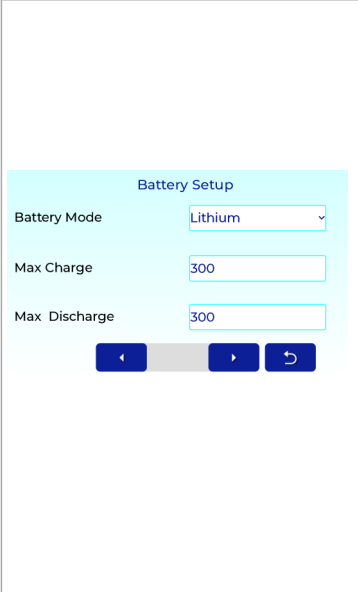
	<p>Step 1: Select Single or Parallel Mode. Select Single and click “” to proceed to the Time Setup.</p>																
	<p>Step 2: Time Setup Clicking the plus or minus signs on the screen can change the numbers to set the current time and date. 12-Hour: The default is 24-hour format. After enabling, it becomes 12-hour format.</p>																
	<p>Step 3: Battery Setup Battery Mode: including three options (Default: Lithium). Lithium: Control the charging and discharging process of battery under the condition of the BMS of battery is communicating with the inverter. User Defined: Control the charging and discharging process directly through battery voltage. No Battery: Tick this item if no battery is connected to the system. Max Charge: Max battery charging current. <table border="1" data-bbox="564 1074 855 1114"> <tr> <td>8KVA</td> <td>10KVA</td> <td>12KVA</td> <td>16KVA</td> </tr> <tr> <td>150A</td> <td>205A</td> <td>240A</td> <td>300A</td> </tr> </table> Max Discharge: Max battery discharging current. For AGM and Flooded, we recommend Ah battery size x 20% = Charge/Discharge amps. For Lithium, we recommend Ah battery size x 50% = Charge/Discharge amps. <table border="1" data-bbox="564 1222 855 1262"> <tr> <td>8KVA</td> <td>10KVA</td> <td>12KVA</td> <td>16KVA</td> </tr> <tr> <td>150A</td> <td>205A</td> <td>240A</td> <td>300A</td> </tr> </table> For Gel, follow manufacturer's instructions. set the current time and date. 12-Hour: The default is 24-hour format. After enabling, it becomes 12-hour format.</p>	8KVA	10KVA	12KVA	16KVA	150A	205A	240A	300A	8KVA	10KVA	12KVA	16KVA	150A	205A	240A	300A
8KVA	10KVA	12KVA	16KVA														
150A	205A	240A	300A														
8KVA	10KVA	12KVA	16KVA														
150A	205A	240A	300A														

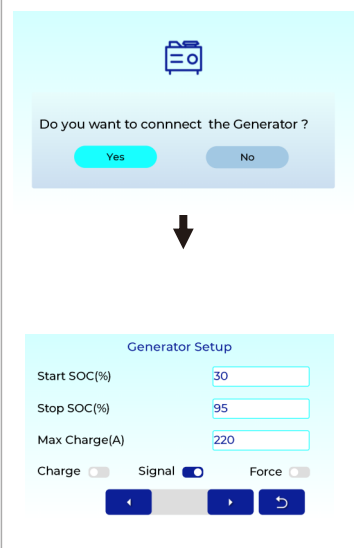
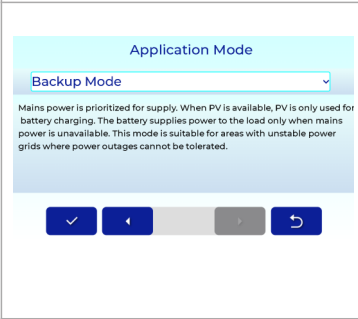
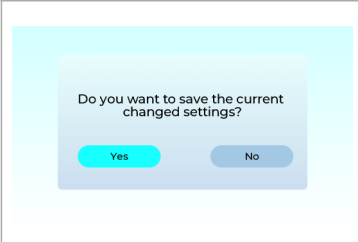
 <p>Do you want to connect the Generator ?</p> <p>Yes No</p> <p>↓</p> <p>Generator Setup</p> <p>Start SOC(%) <input type="text" value="30"/></p> <p>Stop SOC(%) <input type="text" value="95"/></p> <p>Max Charge(A) <input type="text" value="220"/></p> <p>Charge <input type="checkbox"/> Signal <input checked="" type="checkbox"/> Force <input type="checkbox"/></p> <p>← → ↺</p>	<p>Step 4: Do you want to connect the Generator?</p> <ul style="list-style-type: none"> Click "Yes" to proceed to the Generator Setup. Click "No" to proceed to the Application Mode setup. <p>Generator Setup</p> <p>Start: When battery SOC or voltage drops to this set value, the inverter will auto start charge the battery from the GEN port. (Default: 30%)</p> <p>Stop: When the battery SOC or voltage reaches this set value, the inverter will end charge the battery from the GEN port. (Default: 95%)</p> <p>Max Charge: The maximum charging current allowed when only use AC power from the GEN port to charge the battery. (Default: 220A)</p> <p>Charge: It's allowed to absorb AC power from the GEN port to charge the battery.</p> <p>Signal: When conditions are sufficient, the inverter will close or open the normally open relay used to control the start and stop of the generator.</p> <p>Force: When the generator is connected, it is forced to start the generator without meeting other conditions.</p>
 <p>Application Mode</p> <p>Backup Mode</p> <p>Mains power is prioritized for supply. When PV is available, PV is only used for battery charging. The battery supplies power to the load only when mains power is unavailable. This mode is suitable for areas with unstable power grids where power outages cannot be tolerated.</p> <p>✓ ← → ↺</p>	<p>Step 5: Application Mode</p> <p>It includes three working modes: Backup Mode, Intelligent Mode, and Economic Mode. For specific working methods, please refer to Chapter 6.</p> <p>Click "✓" to save all settings.</p>
 <p>Do you want to save the current changed settings?</p> <p>Yes No</p>	<p>Step 6: Do you want to save the Current changed settings?</p> <ul style="list-style-type: none"> Click "YES" to proceed to the Setup is loading. Click "No" to proceed to the Setting Menu.

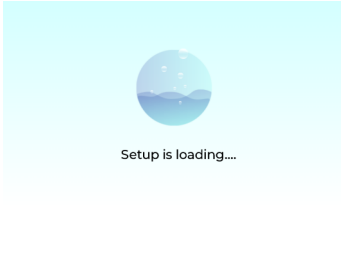
 <p>Setup is loading....</p>  <p>Setup is finished.</p>	<p>After waiting ten seconds, the setup will be completed.</p>
---------------------------------------------------------------------------------------------------------------------------------------------------------------------------------------------------------------------------	----------------------------------------------------------------

5.9 System Work Mode

System Work Mode

Output Mode Single ▾

Application Mode Intelligent Mode ▾

Grid Limit Shaving

Grid Limit Power(W)

Grid Limit Current(A)

✓
⏪
1/1
⏩
↺

Output Mode:(Note: This setting can only be set in standby mode)

Single:Enable this function when a single inverter is used independently.

Single Parallel: Enable this function when several same model hybrid inverters are connecting in parallel.

Three Phase A/B/C: When forming a 3-phase system in parallel, it is necessary to set which phase of the three-phase system this inverter belongs to.

Application Mode:It includes three working modes: Backup Mode, Intelligent Mode, and Economic Mode. For specific working methods, please refer to Chapter 6.

(Note: This setting can only be set in standby mode)

Grid Limit Shaving:When it is active,the inverter will attempt to limit the AC power obtained from the grid.Default:OFF.

Grid Limit Power:Set this value to limit the AC power from the grid. If the grid peak shaving power plus PV power plus battery power cannot meet the power consumption of the load,the grid peak shaving will be invalid, and the power taken from the grid can exceed this set value

8KVA	10KVA	12KVA	16KVA
8000W	10000W	12000W	16000W

Grid Limit current:Set this value to restrict the alternating current in the grid. If the sum of the peak shaving power of the power grid, the photovoltaic power and the battery power cannot meet the power consumption of the load, the current limiting of the power grid will be ineffective, and the current obtained from the power grid may exceed the set value

8KVA	10KVA	12KVA	16KVA
35A	44A	52A	69A

5.10 Basic Setting

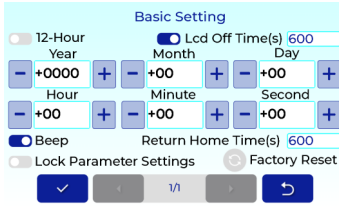
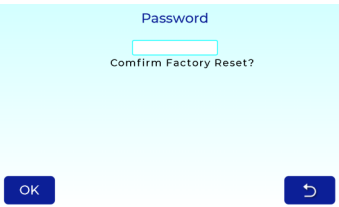
	<p>This is the Basic Setup Page.</p> <p>Time: Set the inverter's local date and time.</p> <p>12-Hour: 12-Hour / 24-Hour Format</p> <p>LCD Off Time: Control the LCD screen's backlight duration(Default:ON).</p> <p>Beep: Enable or disable the buzzer when a fault occurs(Default:ON).</p> <p>Return Home Time: Control the time to return to the home screen(Default:600s).</p> <p>Lock Parameter Settings: Enable this function after completing parameter settings to lock the configured parameters (preventing modifications). To change parameters, this function must be disabled first.</p>
	<p>Click the "Factory Reset" option on "Basic Setup" page, the LCD screen will turn to this page, You can enter a six-digit password and then click the "OK" button to confirm the restoration of all inverter Settings.Click "↩" to quit to restore all the settings.</p> <p>The"Factory Reset"is only effective in standby mode.</p>

5.11 Generator Port Setting

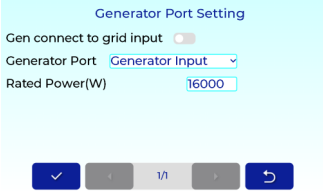
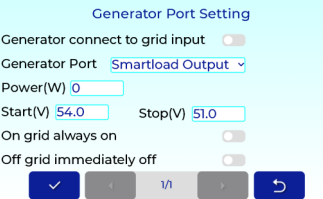
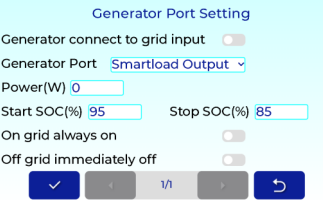
 <p style="text-align: center;">Generator Port Setting</p> <p>Gen connect to grid input <input type="checkbox"/></p> <p>Generator Port Generator Input</p> <p>Rated Power(W) 16000</p> <p style="text-align: center;"> <input type="button" value="✓"/> <input type="button" value="←"/> <input type="button" value="1/1"/> <input type="button" value="→"/> <input type="button" value="↺"/> </p>	<p>GEN port is a multifunctional port, but you can only choose one of the following two functions at a time(Generator Input, Smart Load Output). It can only be set in standby mode.</p> <p>Gen connect to grid input:Connect the generator to the grid input port of the the inverter.</p> <p>Generator Port:Choose type of GEN port, optional:Generator Input, Smart Load Output. (Note: This setting can only be set in standby mode)</p> <p>Rated Power:The maximum input power allowed from generator</p> <table border="1" style="margin-left: 20px; border-collapse: collapse; text-align: center;"> <tr> <td style="padding: 2px;">8KVA</td> <td style="padding: 2px;">10KVA</td> <td style="padding: 2px;">12KVA</td> <td style="padding: 2px;">16KVA</td> </tr> <tr> <td style="padding: 2px;">8000W</td> <td style="padding: 2px;">10000W</td> <td style="padding: 2px;">12000W</td> <td style="padding: 2px;">16000W</td> </tr> </table> <p>(Note: When the generator is connected,this mode</p>	8KVA	10KVA	12KVA	16KVA	8000W	10000W	12000W	16000W
8KVA	10KVA	12KVA	16KVA						
8000W	10000W	12000W	16000W						
 <p style="text-align: center;">Generator Port Setting</p> <p>Generator connect to grid input <input type="checkbox"/></p> <p>Generator Port Smartload Output</p> <p>Power(W) 0</p> <p>Start(V) 54.0 Stop(V) 51.0</p> <p>On grid always on <input type="checkbox"/></p> <p>Off grid immediately off <input type="checkbox"/></p> <p style="text-align: center;"> <input type="button" value="✓"/> <input type="button" value="←"/> <input type="button" value="1/1"/> <input type="button" value="→"/> <input type="button" value="↺"/> </p>	<p>Smart Load Output:</p> <p>Power:Set the PV power for Smart Load Port switch-on.Default:0W.(The PV power setting is only effective in on-grid mode.Set to 0w means the smart load output is not limited by PV power.This setting is not effective in off-grid mode.)</p> <p>Start:Set the battery SOC or voltage for Smart Load Port switch-on(Default:95% SOC or 54.0V).</p> <p>Stop:Set the battery SOC or voltage for Smart Load Port switch-off(Default:85%SOC or 51.0V).</p> <p>On grid always on:When click "On grid always On" the smart load will switch on when the grid is present.</p> <p>Off grid immediately off:The smart load will stop working immediately when the grid is disconnected if this item is active.</p> <p>NOTE:When the conditions for the Smart load output are met, wait for 1 minute, and then the Smartest load will output.</p>								
 <p style="text-align: center;">Generator Port Setting</p> <p>Generator connect to grid input <input type="checkbox"/></p> <p>Generator Port Smartload Output</p> <p>Power(W) 0</p> <p>Start SOC(%) 95 Stop SOC(%) 85</p> <p>On grid always on <input type="checkbox"/></p> <p>Off grid immediately off <input type="checkbox"/></p> <p style="text-align: center;"> <input type="button" value="✓"/> <input type="button" value="←"/> <input type="button" value="1/1"/> <input type="button" value="→"/> <input type="button" value="↺"/> </p>									

5.12 Advanced Function

BMS Err Stop: When it is active, if the battery BMS failed to communicate with inverter, the inverter will stop working and report fault.

MPPT Multi-Point: The inverter will check whether the PV is working on its Max. power point. If not, then it will adjust the voltage of MPPT to ensure the PV operates at the Max.power point.

Low Noise Mode: In this mode, the sound emitted by the inverter during operation will be smaller.

Shutdown Charge: When the ON/OFF switch is not pressed, enabling this function allows utility power to charge the battery; disabling it will prevent charging.

High-V Protect: High-voltage protection point setting. After selecting APL/UPS mode, the default high and low voltage values will be displayed accordingly.(Default:270V)

Low-V Protect: Low-voltage protection point setting. After selecting APL/UPS mode, the corresponding default overvoltage and undervoltage values will be displayed.(Default:90V)

Energy Saving Mode: Enabling this function reduces the inverter's power consumption but also degrades its performance.

Regular Dust Removal: Enabling this function allows the inverter to perform automatic dust removal periodically.

Backup Delay: When the grid cuts off, the inverter will output power after this set time(Default:0ms).

5.13 History Fault Log

Historical Fault Records

Code: Fault Codes & Alarm Codes

Details: Fault Details

Occurred Time: Fault Occurrence Time

Model: Equipment Model

HMI Ver.: HMI (Human-Machine Interface) Board Software Version

WIFI Ver.: WIFI Software Version

SN: Inverter Serial Number

6. Application Mode

Mode I: Backup Mode

Mains power is prioritized for supply. When PV is available, PV is only used for battery charging. The battery supplies power to the load only when mains power is unavailable. This mode is suitable for areas with unstable power grids where power outages cannot be tolerated.

1. When utility power is available and PV (Photovoltaic) power is sufficient, the load is supplied by utility power, and only PV power is used for charging.

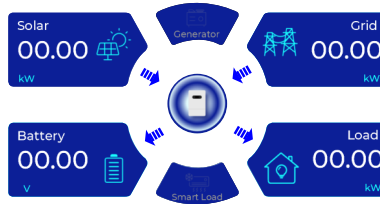

2. When utility power is available but PV (Photovoltaic) power is insufficient, the load is supplied by utility power, and both utility power and PV power are used for charging.

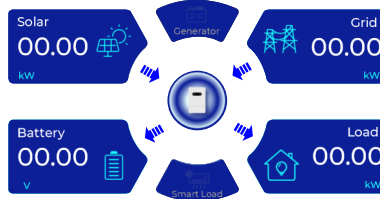

3. When utility power is unavailable and PV (Photovoltaic) power is sufficient, PV power supplies the load and charges the battery.

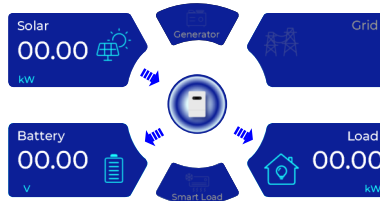

4. When utility power is unavailable and PV (Photovoltaic) power is insufficient, both PV power and the battery supply the load together.

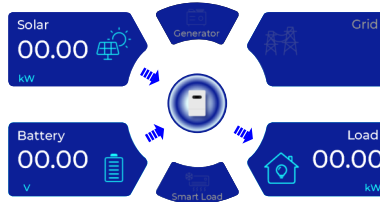

5. When the generator is connected, this mode operates by default.

6. When the battery is fully charged, all PV (Photovoltaic) energy will be wasted.

Mode II: Intelligent Mode

When PV is available, mains power and PV jointly power the load, with surplus PV energy used for battery charging. This mode maximizes PV utilization while maintaining battery capacity, making it suitable for areas with relatively stable power grids where users aim to save on electricity costs and can tolerate occasional power outages.

1. When utility power is available, AC current limiting is enabled, and the load is less than the AC limited power, the entire load is supplied by AC power, and the excess AC energy charges the battery together with PV power.

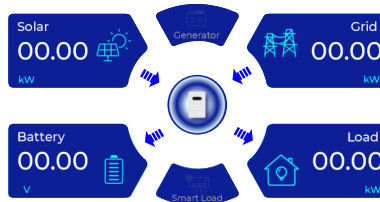

2. When utility power is available, AC current limiting is enabled, and the load exceeds the AC limited power, the load is supplied jointly by AC power and PV power, with the excess PV energy used for charging the battery.

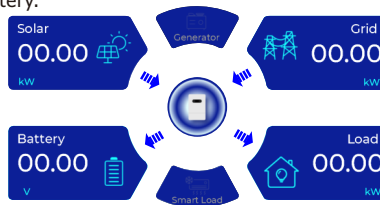

3. When utility power is available, AC current limiting is disabled, and the load is less than the set AC charging power (current battery voltage * Max Charge in page 3 of Battery Setting), the entire load is supplied by AC power, and the excess AC energy charges the battery together with PV power.

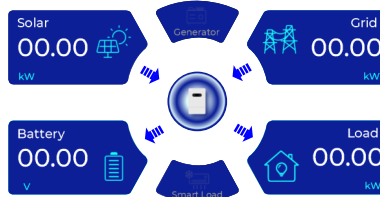

4. When utility power is available, AC current limiting is disabled, and the load exceeds the set AC charging power (current battery voltage * Max Charge in page 3 of Battery Setting), the load is supplied jointly by AC power and PV power, with the excess PV energy used for charging the battery.

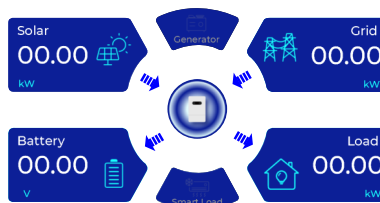

5. When utility power is unavailable and PV power is sufficient, PV power supplies the load and charges the battery.

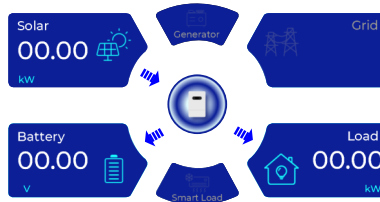

6. When utility power is unavailable and PV power is insufficient, the battery supplements power, and both PV power and the battery supply the load jointly.

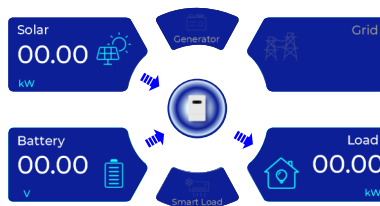

Mode III: Economic Mode

PV is prioritized for supplying power to the load. If PV is insufficient or unavailable, the battery will be used as a supplement to power the load. When the battery voltage reaches the low-voltage threshold, the system will switch to mains power to supply the load. This mode maximizes the use of DC power and is suitable for areas with stable power grids where users aim to save on electricity costs and can tolerate occasional power outages.

1. When utility power is available and the SOC is greater than the Stop SOC, the discharge mode is activated:

a. When utility power is available and PV power is sufficient, PV power supplies the load first, and the excess energy charges the battery.

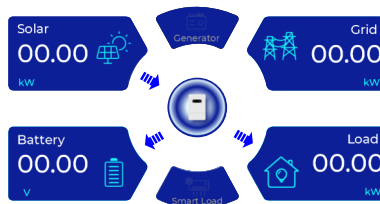

b. When utility power is available but PV (Photovoltaic) power is insufficient, the battery supplements power, and both PV power and the battery supply the load jointly.

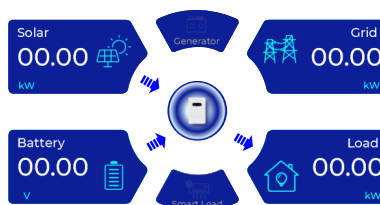

c When utility power is available but both PV power and the battery are insufficient, utility power supplements power, and utility power, PV power, and the battery supply the load jointly.

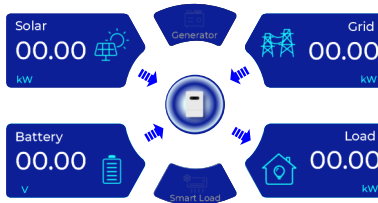

2. When the SOC is less than the Start SOC, the charging mode is activated;

a When utility power is available, AC current limiting is disabled, and PV power is sufficient, PV power charges the battery independently, while utility power supplies the load separately.

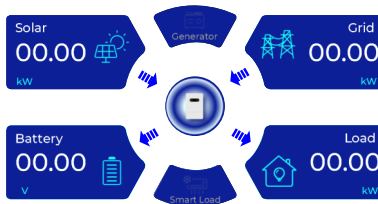

b When utility power is available, AC current limiting is disabled, but PV power is insufficient, utility power supplies the load, and both utility power and PV power charge the battery together.

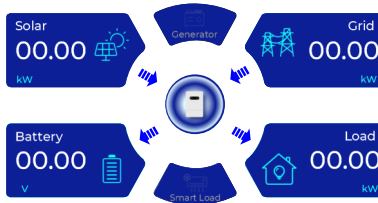

c When utility power is available, AC current limiting is enabled, and PV power is sufficient, PV power charges the battery independently, while utility power supplies the load separately.

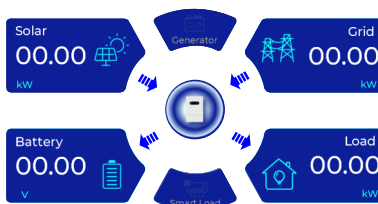

2. When utility power is available, AC current limiting is enabled, but PV power is insufficient, both PV power and AC power charge the battery together.

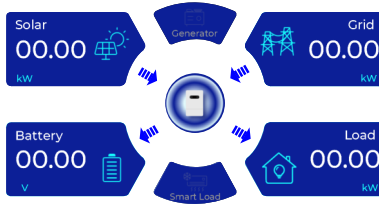

Upon initial power-on, the system defaults to charging the battery until the stop SOC is reached, at which point it switches to discharge mode.

If the charging switch is manually turned off during battery charging, the device automatically enters discharge mode. If the charging switch is then turned on again, and the battery SOC is between start and stop, the device will remain in discharge mode until the start SOC is triggered again, at which point it will enter charging mode.

3. When utility power is unavailable and PV power is sufficient, PV power supplies the load and charges the battery.

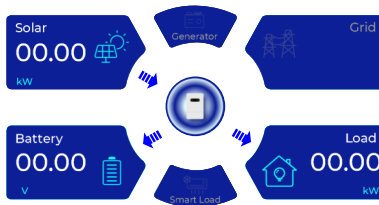

4. When utility power is unavailable but PV power is insufficient, the battery supplements power, and both PV power and the battery supply the load jointly.

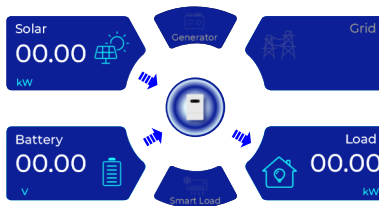

7. Fault information and processing

This inverter complies with safety and electromagnetic compatibility requirements. Before delivery, the inverter has undergone multiple strict tests to ensure reliable operation.

Note

If your inverter shows the Fault Code and the fault persists after restarting, please contact your local dealer or service center. You need to prepare the following information.

1. Inverter serial number;
2. Distributor or service center of the inverter ;
3. Please describe the problem in as much detail as possible (including the fault code and indicator light status). To help you understand the inverter's fault information more clearly, we will list all possible fault codes and their descriptions when the inverter is not functioning properly.
4. Your contact information.

7.1 Warning Code

Warning Code	Warning information	Trouble Shooting
W10	Grid_LoadOver_Alarm	The load is overloaded and should be reduced.
W14	Grid_Abnormal_Alarm	Please check whether the voltage, frequency, and phase sequence of the Grid port are normal
W20	Gen_LoadOver_Alarm	Please check whether the load on backup port is within the generator specifications.
W23	Gen_Abnormal_Alarm	Please check whether the voltage, frequency, and phase sequence of the Gen port are normal
W24	TempOver_Alarm	The inverter will reduce power if the heat sink temperature is too high.
W25	LoadOver_Alarm	The load is overloaded and should be reduced.
W26	Fan_Alarm	Fan malfunction, check fan for proper functioning
W27	Fan_Alarm	Fan malfunction, check fan for proper functioning
W28	Fan_Alarm	Fan malfunction, check fan for proper functioning
W32	Com_DSPToMCU_Alarm	Restart the unit, if the fault still exists, please contact us for help.
W35	BMS_Com_Alarm	Abnormal communication between battery and inverter in lithium mode, check battery and inverter.
W37	BMS_VoltLow_Alarm	Battery SOC is too low, the battery should be charged.

7.2 Fault Code

Fault Code	Fault information	Trouble Shooting
F001	PV1_VoltOver_Fault	1.Please check the voltage of the string, reduce the number of PV1 modules in series; 2.Restart the unit, if the fault still exists, please contact us for help.
F002	PV2_VoltOver_Fault	1.Please check the voltage of the string,reduce the number of PV2 modules in series; 2.Restart the unit, if the fault still exists,please contact us for help.
F003	PV1_CurrOver_Fault	1.The current of the PV1 modules is too large,please check the string current; 2.Restart the unit, if the fault still exists,please contact us for help.
F004	PV2_VoltOver_Fault	1.The current of the PV2 modules is too large,please check the string current; 2.Restart the unit, if the fault still exists,please contact us for help.
F005	PV1_Reverse_Fault	1.Please check whether the PV1 wiring is properly connected; 2.Restart the unit, if the fault still exists,please contact us for help.
F006	PV2_Reverse_Fault	1.Please check whether the PV2 wiring is properly connected; 2.Restart the unit, if the fault still exists,please contact us for help.
F010	PV_TempOver_Fault	1.Please check whether the work environment temperature is too high; 2.Turn off the inverter for 15mins and restart; 3.Seek help from us, if can not go back to normal state.
F012	PV_BoostNTC_Loss	Restart the unit, if the fault still exists,please contact us for help.
F013	PV_LLCNTC_Loss	Restart the unit, if the fault still exists,please contact us for help.
F014	Bat_VoltOver_S_Fault	1.Please check whether the battery voltage is within the specified range; 2.Check whether Battery cables are firmly and correctly connected;
F015	Bat_VoltLow_Fault	1. Please check whether BMS communication cable is firmly and correctly connected; 2. Restart the unit, if the fault still exists, please contact us for help.
F022	PV_CurrOver_H_Fault	Restart the unit, if the fault still exists,please contact us for help.
F023	DCDC_TempOver_Fault	1.Please check whether the work environment temperature is too high; 2.Turn off the inverter for 15mins and restart; 3.Seek help from us, if can not go back to normal state.

Fault Code	Fault information	Trouble Shooting
F026	LLC_CurrOver_H_Fault	Restart the unit, if the fault still exists, please contact us for help.
F027	LLC_LS_TempOver_Fault	1. Please check whether the work environment temperature is too high; 2. Turn off the inverter for 15mins and restart; 3. Seek help from us, if can not go back to normal state.
F028	LLC_TX_TempOver_Fault	1. Please check whether the work environment temperature is too high; 2. Turn off the inverter for 15mins and restart; 3. Seek help from us, if can not go back to normal state.
F029	BUS_VoltOver_S_Fault	1. Please check the voltage of the string, reduce the number of PV modules in series; 2. Restart the unit, if the fault still exists, please contact us for help.
F030	BUS_VoltOver_H_Fault	1. Please check the voltage of the string, reduce the number of PV modules in series; 2. Restart the unit, if the fault still exists, please contact us for help.
F031	BUS_VoltLow_Fault	Restart the unit, if the fault still exists, please contact us for help.
F032	BUS_Soft_Fault	Restart the unit, if the fault still exists, please contact us for help.
F034	INV_Soft_Fault	Restart the unit, if the fault still exists, please contact us for help.
F035	INV_Volt_Fault	1. Please check whether the load power is within the specified range; 2. Restart the unit, if the fault still exists, please contact us for help.
F036	INV_CurrOver_S_Fault	1. Please check whether the load power is within the specified range; 2. Restart the unit, if the fault still exists, please contact us for help.
F37	INV_CurrOver_H_Fault	1. Please check whether the load power is within the specified range; 2. Restart the unit, if the fault still exists, please contact us for help.
F038	INV_Short_Fault	1. Please check whether the connection of backup is firmly and correctly; 2. Restart the unit, if the fault still exists, please contact us for help.
F041	INV_TempOver_Fault	1. Please check whether the work environment temperature is too high; 2. Turn off the inverter for 15mins and restart; 3. Seek help from us, if can not go back to normal state.
F042	INV_NegPower_Fault	Restart the unit, if the fault still exists, please contact us for help.

Fault Code	Fault information	Trouble Shooting
F045	INV_TX_NTC_Loss	Restart the unit, if the fault still exists, please contact us for help.
F046	INV_Hs_NTC_Loss	Restart the unit, if the fault still exists, please contact us for help.
F047	INV_TX_TempOver	1. Please check whether the work environment temperature is too high; 2. Turn off the inverter for 15mins and restart;
F048	Load_Over_Fault	1. Please check whether the load power is within the specified range; 2. Restart the unit, if the fault still exists, please contact us for help.
F049	OUT_VoltLow_Fault	Restart the unit, if the fault still exists, please contact us for help.
F050	OUT_VoltOver_Fault	Restart the unit, if the fault still exists, please contact us for help.
F052	Bat_TempOver_Fault	1. Please check whether the work environment temperature is too high; 2. Turn off the inverter for 15mins and restart; 3. Seek help from us, if can not go back to normal state.
F056	Eeprom_Fault	Restart the unit, if the fault still exists, please contact us for help.
F057	Safe_PvISO_Fault	Restart the unit, if the fault still exists, please contact us for help.
F059	Grid_Relay_Open_Fault	Restart the unit, if the fault still exists, please contact us for help.
F060	Grid_Relay_Short_Fault	Restart the unit, if the fault still exists, please contact us for help.
F061	Gen_Relay_Open_Fault	Restart the unit, if the fault still exists, please contact us for help.
F062	Gen_Relay_Short_Fault	Restart the unit, if the fault still exists, please contact us for help.
F063	INV_Relay_Open_Fault	Restart the unit, if the fault still exists, please contact us for help.
F070	Para_CANCom_Fault	1. Please check whether the parallel cables are firmly and correctly connected; 2. Restart the system, If the fault still exists, please contact us for help.
F071	Para_MasterLoss_Fault	1. Please check whether the parallel cables are firmly and correctly connected; 2. Restart the system, If the fault still exists, please contact us for help.
F072	Para_ZeroSyncLoss_Fault	1. Please check whether the parallel cables are firmly and correctly connected; 2. Restart the system, If the fault still exists, please contact us for help.

Fault Code	Fault information	Trouble Shooting
F073	Para_ACSourceDiff_Faultt	Check whether the wiring of the mains power or oil engine is correct.
F075	Para_OpSetDiff_Fault	1.Please check whether the parallel cables are firmly and Correctly Connected; 2.Check whether the software version of the inverter is same.
F078	PvOutCurrCT_Fault	Restart the unit, if the fault still exists,please contact us for help.
F079	INV_CurrCT_Fault	Restart the unit, if the fault still exists,please contact us for help.
F080	Bat_CurrCT_Fault	Restart the unit, if the fault still exists,please contact us for help.
F081	Grid_CurrCT_Fault	Restart the unit, if the fault still exists,please contact us for help.
F082	Gen_CurrCT_Fault	Restart the unit, if the fault still exists,please contact us for help.
F083	Pv_CurrCT_Fault	Restart the unit, if the fault still exists,please contact us for help.
F085	Bootload_Fail	Restart the unit, if the fault still exists,please contact us for help.
F086	AuxPowerFault	Restart the unit, if the fault still exists,please contact us for help.
F087	PvBusOv	Restart the unit, if the fault still exists,please contact us for help.
F088	Wire Fault	Restart the unit, if the fault still exists,please contact us for help.
F089	InternalTemp_Ov Fault	1.Please check whether the work environment temperature is too high; 2.Turn off the inverter for 15mins and restart; 3.Seek help from us, if can not go back to normal state.

Under the guidance of our company, customers return our products so that our company can provide service of maintenance or replacement of products of the same value. Customers need to pay the necessary freight and other related costs. Any replacement or repair of the product will cover the remaining warranty period of the product. If any part of the product or product is replaced by the company itself during the warranty period, all rights and interests of the replacement product or component belong to the company.

Factory warranty does not include damage due to the following reasons:

- Damage during transportation of equipment ;
- Damage caused by incorrect installation or commissioning ;
- Damage caused by failure to comply with operation instructions, installation instructions or maintenance instructions ;
- Damage caused by attempts to modify, alter or repair products ;
- Damage caused by incorrect use or operation ;
- Damage caused by insufficient ventilation of equipment ;
- Damage caused by failure to comply with applicable safety standards or regulations ;
- Damage caused by natural disasters or force majeure (e.g. floods, lightning, overvoltage, storms, fires, etc.)

In addition, normal wear or any other failure will not affect the basic operation of the product. Any external scratches, stains or natural mechanical wear does not represent a defect in the product.

8. Limitation of Liability

In addition to the product warranty described above, the state and local laws and regulations provide financial compensation for the product's power connection (including violation of implied terms and warranties). The company hereby declares that the terms and conditions of the product and the policy cannot and can only legally exclude all liability within a limited scope.

9. Datasheet

Line Mode Specifications				
Model	IVPM8048 P1G2-PRO	IVPM10048 P1G2-PRO	IVPM12048 P1G2-PRO	IVPM16048 P1G2-PRO
Rated Output Power	8000VA	10000VA	12000VA	16000VA
	6400W	8000W	9600W	12800W
Nominal DC Input Voltage	48V			
Input Voltage Waveform	Sinusoidal(Utility or generator)			
Nominal Input Voltage	230Vac			
Low Line Disconnect	170±7Vac(UPS)90±7Vac(APL)			
Low Line Re-connect AC Input Range	180±7Vac(UPS)100±7Vac(APL)			
High Line Disconnect	270±7Vac			
High Line Re-connect	260±7Vac			
Max AC Input Voltage	250Vrms			
Nominal Input Frequency	50Hz/60Hz			
Low Line Frequency Disconnect	45±0.5Hz			
Low Line Frequency Re-connect	47±0.5Hz			
High Line Frequency Disconnect	65±0.5Hz			
High Line Frequency Re-connect	63±0.5Hz			
Output Voltage Waveform	As same as input waveform			
Output Short Circuit Protection	Mains mode: External air switch protection Battery mode: Electric circuit			
Switching Time (Standalone)	8ms typical(UPS) 15ms typical(APL)			
Switching Time (Parallel Operation)	20ms typical			
Battery-Free Operation	Bypass Available			
Max Bypass Overload Current	AC 35A	AC 44A	AC 52A	AC 69A
Maximum Bypass Current/Power	42A/9.6KVA	53A/12KVA	62A/12KVA	82.8A/19.2KVA
Maximum Rectification Current/Power	35A/8KW	44A/10KW	52A/10KW	69A/16KW
Number of Input Circuits	2 (default generator convertible output)			
Number of Output Circuits	2 (second circuit converted via generator port)			
Utility Charge Mode Specifications				
Nominal Input Voltage	230Vac			
Input Voltage Range	90~270Vac			
Nominal Output Voltage	Dependent on battery type			
Max Charge Current	120A	150A	170A	220A
Charge Current Regulation	0A-120A	0A-150A	0A-170A	0A~220A
Over Charge Protection	Yes			

Solar Charging & Utility Charging(MPPT built-in controller is optional)				
Max PV Open Circuit Voltage	525Vdc			
PV Aray MPPT Voltage Range	100-450Vdc			
MPPT Full-Load Voltage Range	320-450Vdc			
Startup Voltage	125V			
Max Input Power	8.9KW	8.9KW+8.9KW	17kW+8.5kW	
Max Solar Charging Current	150A	240A	350A	
Maximum Charging Current (PV + Mains)	150A	240A	350A	
Maximum PV Operating Input Current	27A	20A+20A	40A+20A	
Maximum PV Short-Circuit Current	35A	25A+25A	44A+22A	
Number of Controllers/Strings	1/2	2/1+1	2/2+1	
PV Insulation Fault	100kΩ			
Inverter Mode Specifications				
Rated Output Power	8000VA	10000VA	12000VA	16000VA
	6400W	8000W	9600W	12800W
Nominal DC Input Voltage	48V			
Output Voltage Waveform	Pure sine wave			
Nominal Output Voltage	230Vac±2%			
Nominal Output Frequency	50±0.3Hz/60Hz±0.3Hz			
Peak Efficiency	93%			
Total Voltage Harmonic Distortion THDV	<3%(of nominal power)			
Over-Load Protection	10min@102%~110% load			
Surge rating	2* rated power for 5 seconds			
Output Short Circuit Protection	Yes			
Number of Parallel Units	12			
Dual Output	Yes			
Interface				
Display	LCD+LED			
Communication Interface	RS485,CAN			
Monitor Mode	WIFI/Bluetooth			
General Specifications				
Operating temperature	-10°C ~ +55°C			
Storage temperature	-15°C ~ +60°C			
Humidity	10% to 90% Relative Humidity			
Ingress Protection	IP21			
Net Weight	61.7KG	70.7KG	71.0KG	95.5KG
Gross Weight	80.7KG	89.7KG	91.0KG	115KG
Bare Unit Dimensions	704x460x309mm	704x460x309mm	704x460x309mm	764x460x410mm
Package Dimensions	810x570x482mm	810x570x482mm	810x570x482mm	880x570x584mm

10. Appendix I

Definition of RJ45 Port Pin for BMS

No.	BMS Pin
1	GND
2	/
3	CAN-L
4	CAN-H
5	BMS-485_B
6	BMS-485_A
7	/
8	/



8.....1

8.....1

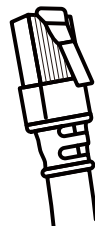

Definition of RJ45 Port Pin of "RS485 port" for remotely monitoring

No.	RS485 Pin
1	PC-485_B
2	PC-485_A
3	/
4	/
5	/
6	/
7	/
8	GND



8.....1

8.....1

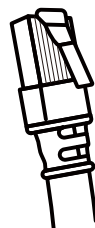

11. The Wi-Fi operation Guide in APP

11.1 Introduction

Wireless communication between the off-grid inverter and the APP can be realized through the Wi-Fi module. The APP supports Android and iOS devices.

Delivers device status during normal operation.

Allows device Settings to be configured on the APP.

Notifies users when a warning or alarm occurs.

Allows users to query inverter history data.

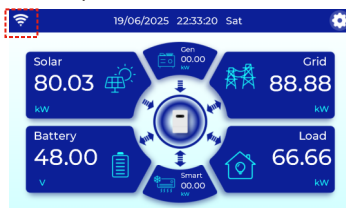



The status of the Wi-Fi sign on the LCD display.

After the APP is successfully connected, Wi-Fi indicator light remains constantly on.

11.2 Download and install APP

Operating system requirement for your smart phone:

-  iOS system supports iOS 11.0 and above
-  Android system supports Android 5.0 above

APP Download

Please scan the following QR code with your smartphone to download the App.



The QR code supports Android system and iOS system

Operation Manual

Please scan the following QR code with your smartphone to view the App Operation Manual



The QR code supports Android system and iOS system

Zero Export To Load:The AC output power will only supply the backup load and smart load (if any).The Inverter will neither supply power to homeloads nor sell power to the grid.The built-in CT will detect the power flowing back to the grid port, and then the inverter will adjust its AC output power based on the detected value to prevent AC current from being output from the grid port of the inverter. Default:ON.

Guangzhou Felicity Solar Technology Co., Ltd.

✉ Email: sales@felicitysolar.com

🌐 Web: www.felicitysolar.com

📍 Add: (Airport Baiyun)No.2, 4, 6, 8, 10 and 12 Donghua Huaye Road, Renhe Town, Baiyun District,
Guangzhou, Guangdong, P. R. China