

# USER GUIDE

IVGM12KLP3G2

IVGM10KLP3G2

IVGM8KLP3G2

IVGM6KLP3G2

IVGM5KLP3G2

IVGM4KLP3G2

IVGM3KLP3G2

*Hybrid inverter*



# Contents

1. SAFETY & WARNING .....	2
2. Product Introduction .....	2
2.1 Product Features .....	3
2.2 Basic System Architecture.....	3
2.3 Products Overview.....	4
3. Installation.....	6
3.1 Packing List.....	6
3.2 Product Handling Requirements.....	7
3.3 Installation Tools .....	8
3.4 Installation Environment.....	9
3.5 Mounting.....	11
4. Electrical connection .....	12
4.1 PV Connection .....	12
4.2 Battery Connection.....	14
4.3 Grid, Load and Gen Port Connection .....	16
4.4 Earth Connection .....	19
4.5 Function Port Definition.....	19
4.6 Smart Meter Connection(Reserve).....	21
4.7 CT Connection.....	24
4.8 DRMS Connection.....	25
4.9 Lithium Battery Communication.....	26
4.10 Installation of WIFI Module .....	27
4.11 Wire System For Inverter.....	28
4.12 Typical Application Diagram of Diesel Generator.....	30
4.13 Three Phase Parallel Inverter.....	31

5. Display and Operation .....	32
5.1 Inverter Power ON/OFF.....	32
5.2 Operation and Display Panel.....	33
5.3 LCD Display Icons.....	33
5.4 Power Curve.....	34
5.5 Basic Setting.....	35
5.6 Battery Setting.....	36
5.7 Work Mode Setting.....	38
5.8 Grid Setting.....	42
5.9 Gen Port Setting.....	46
5.10 Advanced Function.....	48
6. System Application.....	50
7. Warranty.....	53
8. Troubleshooting.....	53
9. APP Download the APP.....	54
10. Warning Code.....	54
11. Fault Code.....	56
12. Appendix .....	60

## About This Manual

The manual mainly describes the product information, guidelines for installation, operation and maintenance. The manual cannot include complete information about the photovoltaic (PV) system.

## How to Use This Manual

Read the manual and other related documents before performing any operation on the inverter. Documents must be stored carefully and be available at all times. Contents may be periodically updated or revised due to product development. The information in this manual is subject to change without notice. The latest manual can be acquired via our website at <https://www.felicitysolar.com> for latest version.

## Safety Introductions









This chapter contains important safety and operating instructions. Read and keep this manual for future reference.

- Before using the inverter, please read the instructions and warning signs of the battery and corresponding sections in the instruction manual.
- Do not disassemble the inverter. If you need maintenance or repair, take it to a professional service center.
- Improper reassembly may result in electric shock or fire.
- To reduce risk of electric shock, disconnect all wires before attempting any maintenance or cleaning. Turning off the unit will not reduce this risk.
- Caution: Only qualified personnel can install this device with battery.
- Never charge a frozen battery.
- For optimum operation of this inverter, please follow required specification to select appropriate cable size. It is very important to correctly operate this inverter.
- Be very cautious when working with metal tools on or around batteries. Dropping a tool may cause a spark or short circuit in batteries or other electrical parts, even cause an explosion.
- Please strictly follow installation procedure when you want to disconnect AC or DC terminals. Please refer to "Installation" section of this manual for the details.
- Grounding instructions - this inverter should be connected to a permanent grounded wiring system. Be sure to comply with local requirements and regulation to install this inverter.
- Never cause AC output and DC input short circuited. Do not connect to the mains when DC input short circuits.

## 1. SAFETY & WARNING

This manual provides relevant information with icons to highlight the physical and property safety of the user to avoid device damage and physical injury.

The Symbols used in this manual are listed as below:

Symbols	Name	Instruction
	Danger	Serious physical injury or even death may occur if not follow the relative requirements
	Warning	Physical injury or damage to the devices may occur if not follow the relative requirements
	Electrostatic sensitive	Damage may occur if not follow the relative requirements
	Hot surface	Sides of the device may become hot. Do not touch.
	Earth terminal	The inverter must be reliably grounded.
	Caution	Ensure that DC and AC side circuit breakers have been disconnected and wait at least 5 minutes before wiring and checking.
NOTE	Note	The procedures taken for ensuring proper operation.
	CE mark	The inverter complies with the CE directive.
	EU WEEE mark	Product should not be disposed as household waste.

## 2. Product Introduction

Felicitysolar IVGM Series is a multifunctional inverter, combining functions of inverter, solar charger and battery charger to offer uninterruptible power support with portable size. Its comprehensive LCD display offers user configurable and easy accessible button operation such as battery charging, AC/solar charging, and acceptable input voltage based on different applications.

## 2.1 Product Features

- 230V/400V Three phase Pure sine wave inverter.
- Self-consumption and feed-in to the grid.
- Auto restart while AC is recovering.
- Programmable supply priority for battery or grid.
- Programmable multiple operation modes: On grid, Off grid and UPS.
- With limit function, prevent excess power overflow to the grid.
- Supporting WIFI monitoring and Fsolar Smart Cloud Monitoring System.
- 4-channel PV, 2-channel MPPT, 1.6 times overconfiguration capacity.
- Battery charge and discharge current up to 240A.
- Programmable generator port, support smart load and microinverter access.
- The off-grid switching time is less than 10ms to prevent important loads from losing power.
- Support multi Working mode, Time Of Use, Selling First, Zero Export To Load, Zero Export To CT.
- IP65 protection level.

## 2.2 Basic System Architecture

The following illustration shows basic application of this inverter. It also includes following devices to have a complete running system.

- Generator or Utility
- PV modules

Consult with your system integrator for other possible system architectures depending on your requirements.

This inverter can power all kinds of appliances in home or office environment, including motor type appliances such as refrigerator and air conditioner.

Please refer to the Figure 2.2-1 for details.

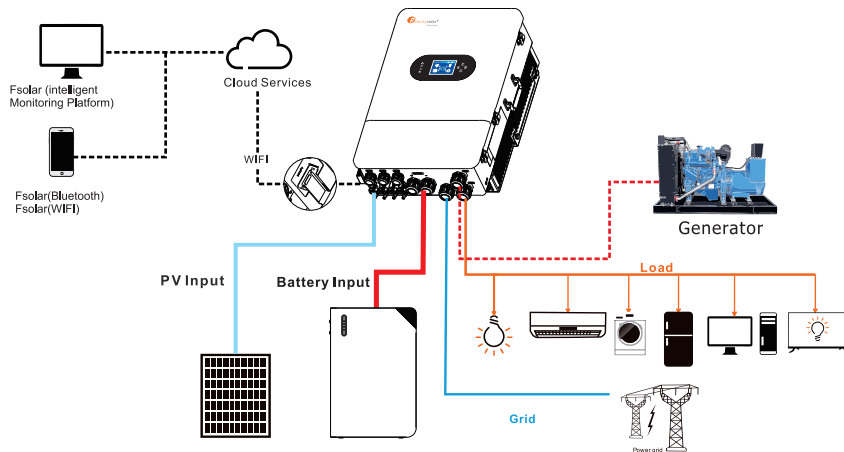

Figure 2.2-1 Block diagram of hybrid solar inverter system

## 2.3 Products Overview

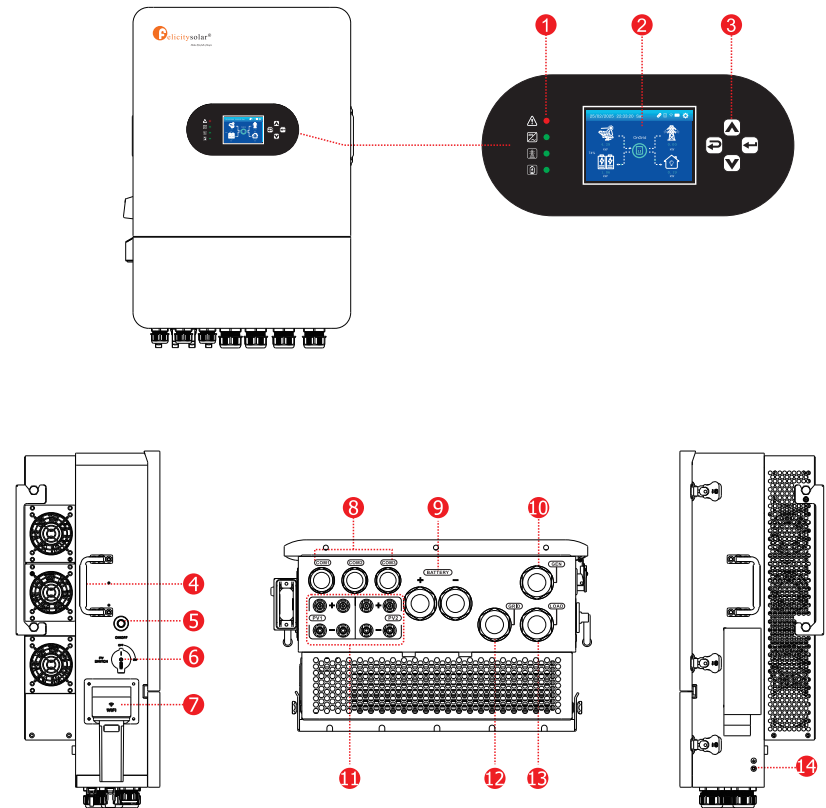

Figure 2.3-1 Products overview

- |                        |                                   |                     |
|------------------------|-----------------------------------|---------------------|
| 1. Inverter Indicators | 6. PV Switch                      | 11. PV Port         |
| 2. LCD Display         | 7. WIFI Interface                 | 12. GRID Port       |
| 3. Function Buttons    | 8. COMM Interface                 | 13. LOAD Port       |
| 4. Handle              | 9. Battery Input/Output Interface | 14. Grounding Point |
| 5. Power on/off        | 10. GEN Port                      |                     |

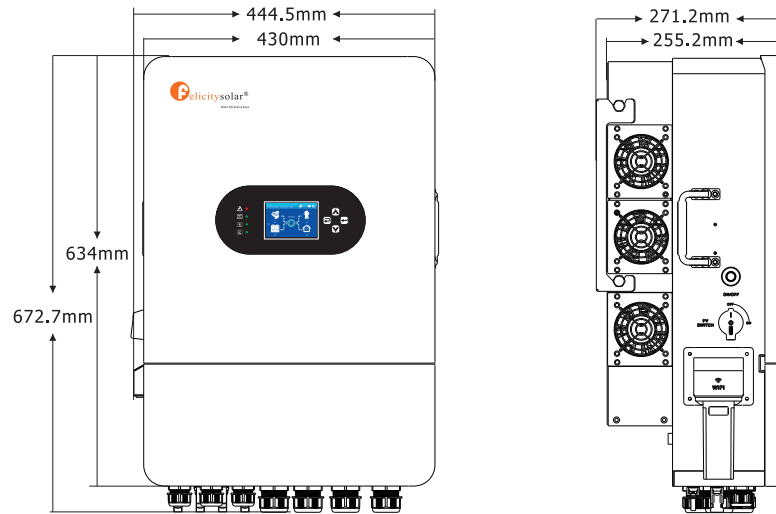

Figure 2.3-2 Inverter dimensions

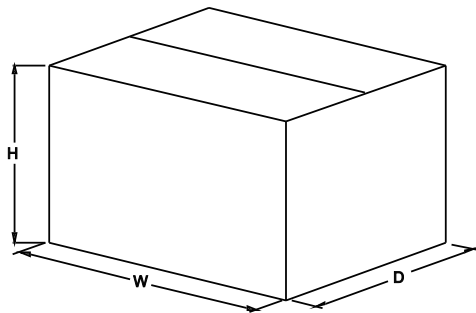

Table 2.3-1 Packages dimension and gross weight

Model	H (mm)	W (mm)	D (mm)	Net Weight (KG)	Gross Weight (KG)
IVGM12KLP3G2 IVGM10KLP3G2 IVGM8KLP3G2 IVGM6KLP3G2 IVGM5KLP3G2 IVGM4KLP3G2 IVGM3KLP3G2	398	771	526	37.8	47.4

### 3. Installation

#### 3.1 Packing List

The inverter 100% strictly inspected before package and delivery. Please check the product package and fittings carefully before installation.

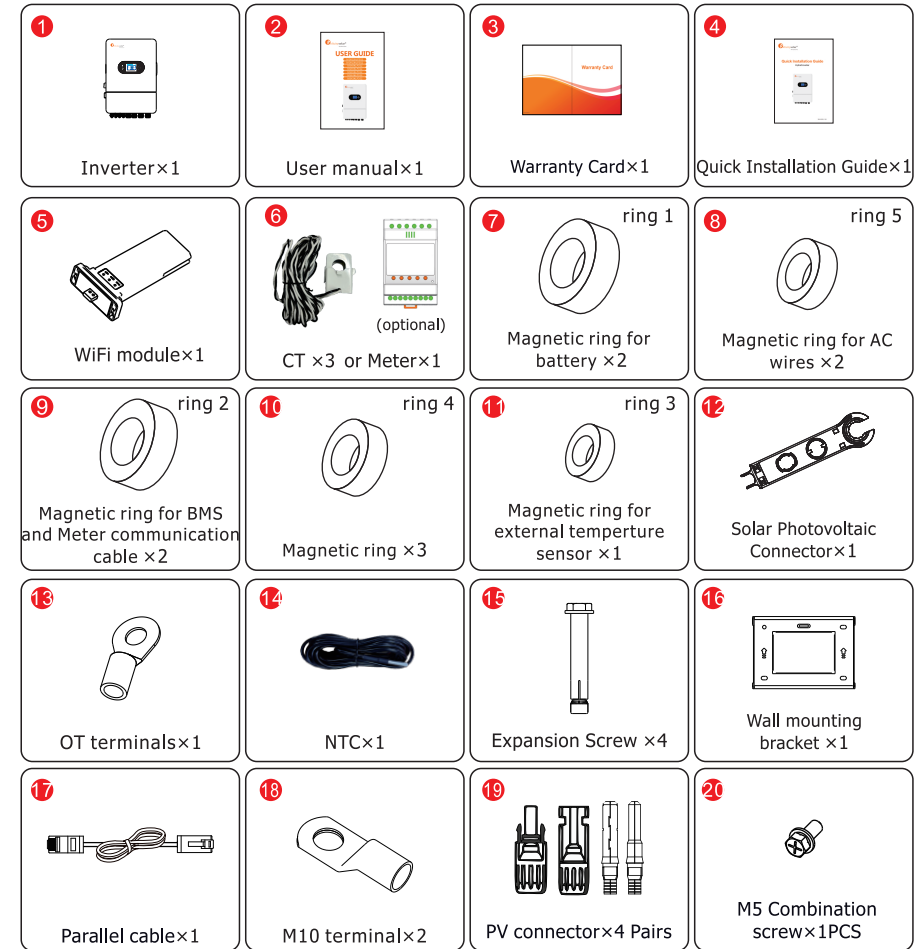

Figure 3.1-1 Packing List

#### Packing box of magnetic ring

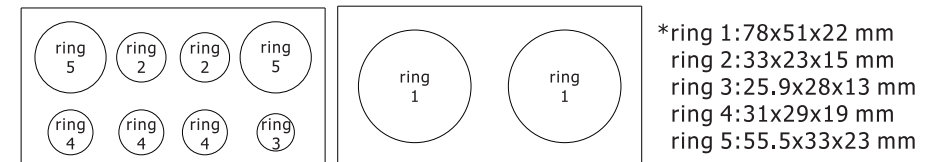

Table 3.1-1 Detailed delivery list

No.	Name	Description	Quantity
1	Inverter	Inverter	1
2	User manual	User manual	1
3	Warranty card	Warranty card	1
4	Quick installation guide	Quick installation guide	1
5	WiFi module	For installing the WiFi module	1
6	Meter or CT	Meter and anti backflow	/
7	Ring 1	Magnetic ring 1 for battery	2
8	Ring 5	Magnetic ring 5 for AC wires	2
9	Ring 2	Magnetic ring 2 for BMS and Meter communication cable	2
10	Ring 4	Magnetic ring 4 for parallel operation*2 and DRMS	3
11	Ring 3	Magnetic ring 3 for external temperture sensor	1
12	Solar photovoltaic connector special spanner	Used for installing and disassembling photovoltaic systems	1
13	OT terminals	For external ground connection	1
14	NTC	Battery Temperature sensor	1
15	Expansion screw	Used for securing the product's wall mount	4
16	Wall mounting bracket	Used to fix the inverter to the wall	1
17	Parallel cable	Used for parallel wiring	1
18	M10 terminal	For crimping BAT cables	2
19	PV connector	PV Port Connectors	4 Pairs
20	Screws	M5 Combination screw	1

## 3.2 Poduct Handling Requirements

Lift the inverter out of the paper package and transport it to the designated installation.

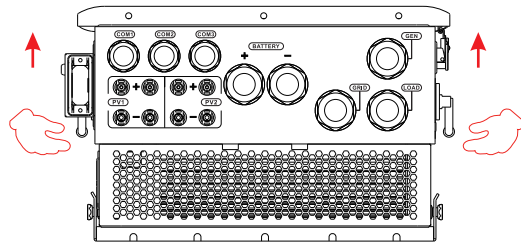

Figure 3.2-1 Lift the inverter



### CAUTION:

Improper handling may cause personal injury!

- Arrange an appropriate number of personnel to carry the inverter according to its weight, and installation personnel should wear protective equipment such as anti-impact shoes and gloves.
- Placing the inverter directly on a hard ground may cause damage to its metal enclosure. Protective materials such as sponge pad or foam cushion should be placed underneath the inverter.
- Move the inverter by one or two people or by using a proper transport tool. Move the inverter by holding the handles on it. Do not move the inverter by holding the terminals.

## 3.3 Installation Tools

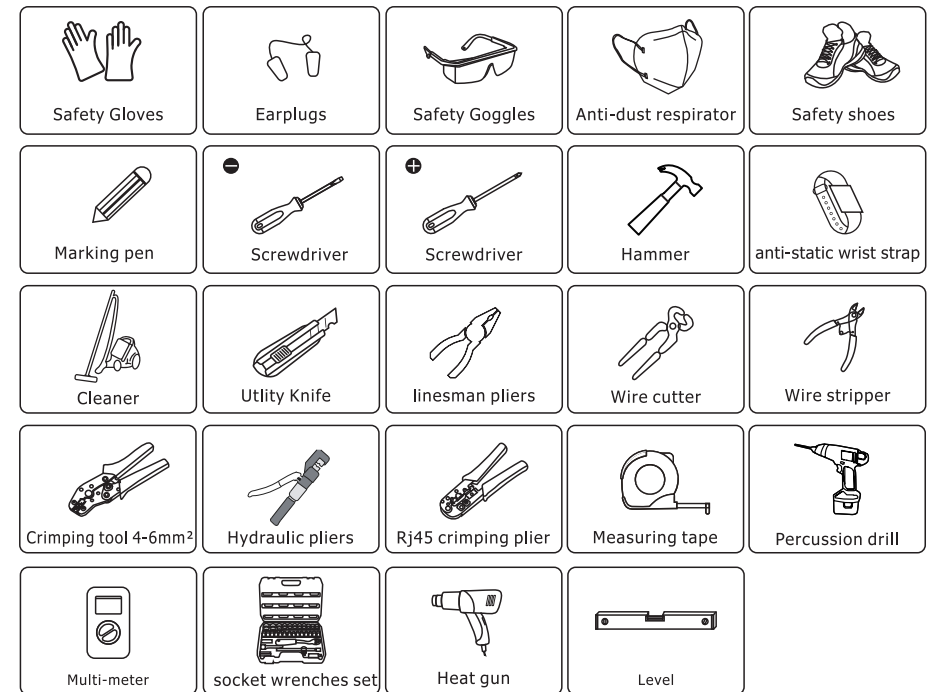

Figure 3.3-1 Installation tools

### 3.4 Installation Environment

- ◇ Choose a dry, clean, and tidy place, convenient for installation
- ◇ Ambient temperature range: -40°C ~ 60°C
- ◇ Relative humidity: 0 ~ 95% (non-condensed)
- ◇ Install in a well-ventilated place
- ◇ No flammable or explosive materials close to inverter
- ◇ The AC overvoltage category of inverter is category III
- ◇ Maximum altitude: 2000m



• Inverter cannot be installed near flammable, explosive or strong electro-magnetic equipment.

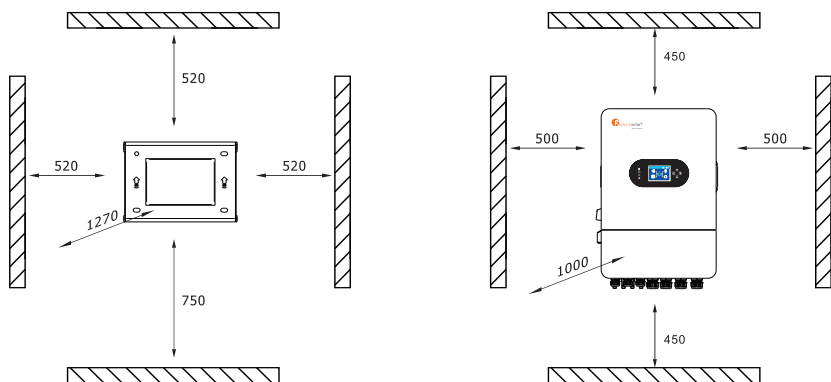

Figure 3.4-1 Installation space of one inverter

**Considering the following points before selecting where to install:**

- Please select a vertical wall with load-bearing capacity for installation, suitable for installation on concrete or other non-flammable surfaces, installation is shown below.
- Install this inverter at eye level in order to allow the LCD display to be read at all times.
- The ambient temperature should be between -40~60°C to ensure optimal operation.
- Be sure to keep other objects and surfaces as shown in the diagram to guarantee sufficient heat dissipation and have enough space for removing wires.

Table 3-4-1 Detailed installation space

	Minimum clearance(Wall Mount Bracket)	Minimum clearance(Inverter)
Lateral	520mm	500mm
Top	520mm	450mm
Bottom	750mm	450mm
Front	1270mm	1000mm

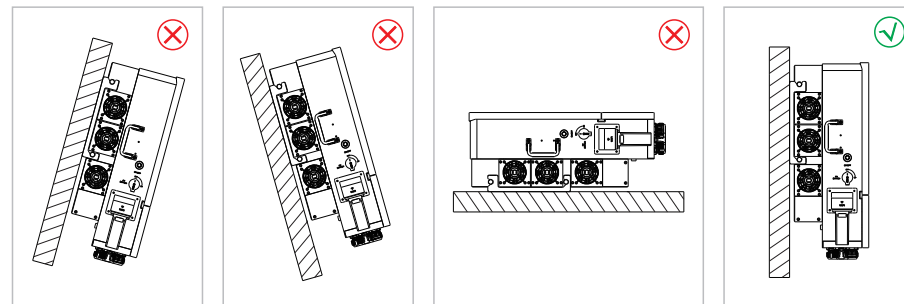

Figure 3.4-2 Installation position



• Do not open the cover of the inverter or replace any part as incomplete inverter may cause electric shock and damage the device during operation.

The installation of inverter should be protected under shelter from direct sunlight or bad weather like snow, rain, lightning etc.

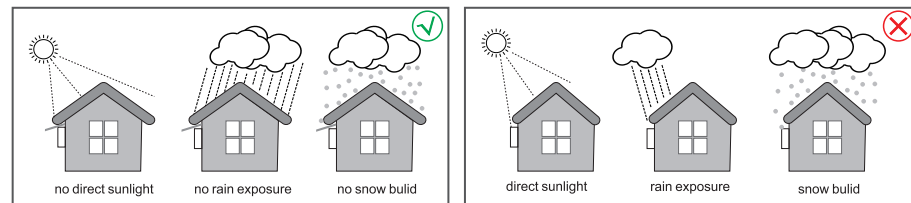

Figure 3.4-3 Installation position

### 3.5 Mounting



- The inverter is too heavy, please be careful when lifting out from the package.
- Hold the handle to lift out the inverter.

The inverter is suitable for mounting on concrete or other non-combustible surface only.  
**Step 1.** When installing wall-mounted components, please first level them with the spirit level, and then drill holes for installation. Please drill 4 holes at the designated positions with the template and M12 drill bit (as shown in the figure below), ensuring the drilling depth is within the range of 65~75mm. After aligning the wall-mounted accessory with the hole position, insert the expansion bolt into the hole with a suitable hammer, and then tighten the expansion bolt with a torque of 12N.m (after tightening the expansion bolt, please ensure that the wall-mounted accessory is firmly fixed to the wall).

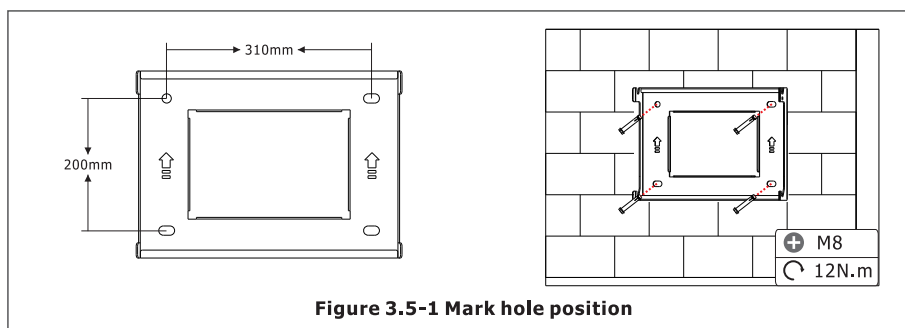

Figure 3.5-1 Mark hole position

**Step 2.** Lift and hold the inverter to ensure that the wall-mounted component on the inverter cabinet is aligned with the one fixed on the wall, as shown in the figure. Install it onto the wall-mounted component on the wall to complete the installation.

After the wall-mounted installation is completed, please fasten it with M5X16 screws.

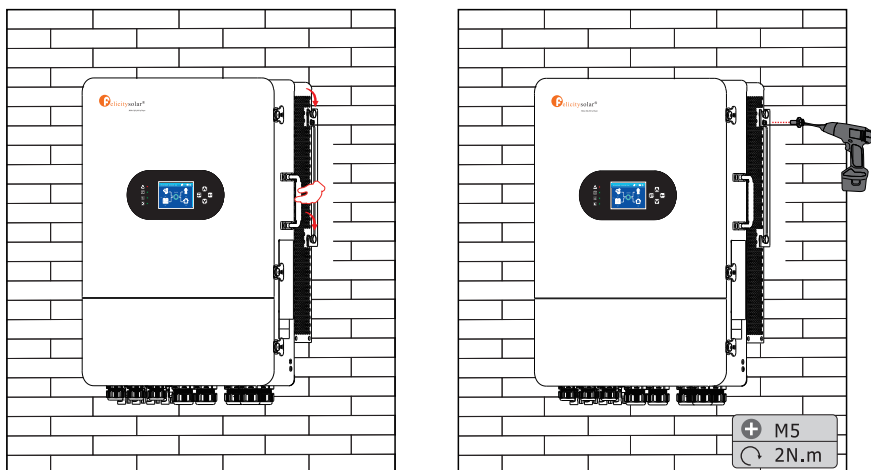

Figure 3.5-2 Install Inverter hanging plate

### 4 Electrical Connection

- ◇ High voltages in power conversion circuits. Lethal hazard of electric shock or serious burns.
- ◇ All work on the PV modules, inverters, and battery systems must be carried out by qualified personnel only.
- ◇ Wear rubber gloves and protective clothing (protective glasses and boots) when working on high voltage/high current systems such as INVERTER and battery systems.

#### 4.1 PV Connection

1. Switch the Grid Supply Main Switch(AC)OFF.
2. Switch the DC Isolator OFF.
3. Assemble PV input connector to the inverter.



- Before connection, please make sure the polarity of PV array matches the "PV+" and "PV-" symbols
- Before connecting to inverter, please make sure the open circuit voltage of PV strings haven't exceeded the max.PV input voltage of the inverter.
- Please use approved DC cable for PV system.

To reduce the risk of injury, please use the proper recommended cable size as below.

Table 4.1-2 Detailed wire size

Inverter Model	Wire Size	Cable(mm <sup>2</sup> )
IVGM12KLP3G2 IVGM10KLP3G2 IVGM8KLP3G2 IVGM6KLP3G2 IVGM5KLP3G2 IVGM4KLP3G2 IVGM3KLP3G2	10AWG	4mm <sup>2</sup>

The steps to assemble the PV connectors are listed as follows:

**Step 1.** Strip the insulation of the PV wire by 7mm, disassemble the cap nut of the connector, thread one PV wire through the cap nut of the connector. Repeat this operation with all the PV wires, paying special attention to the polarity of the connector, as shown in Figure 4.1-1.

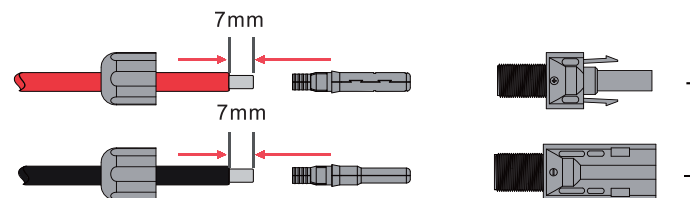

Figure 4.1-1 Pv cables and pv plugs

**Step 2.** Crimping metal terminals with crimping pliers, as shown in Figure 4.1-2.

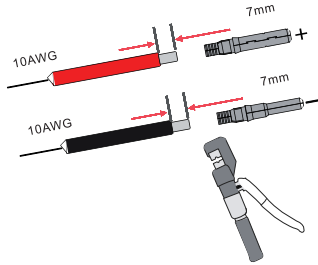

Figure 4.1-2 Crimp the terminal to the wire

**Step 3.** Insert the contact pin to the top part of the connector and completely tighten the cap nut to the top part of the connector, as shown in Figure 4.1-3.

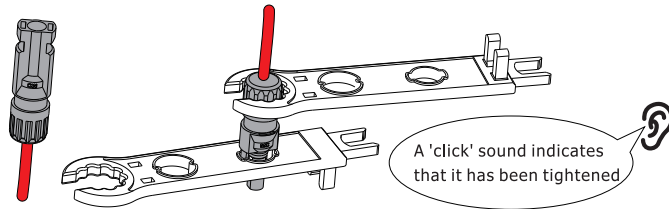

Figure 4.1-3 Connector with cap nut screwed on

**Step 4.** Screw the cap on and plug it onto inverter side. There will be a click sound if connectors are inserted correctly into PV plugs, as shown in Figure 4.1-4.

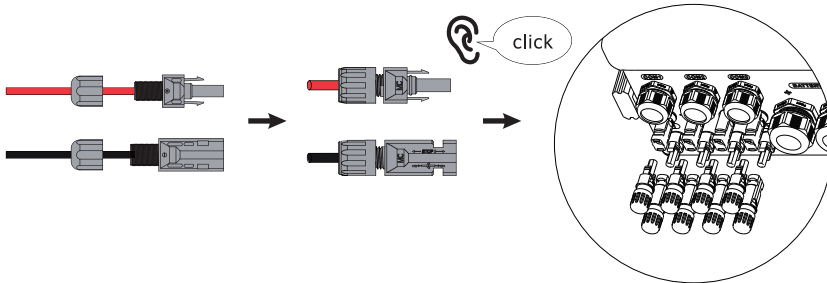

Figure 4.1-4 The PV plug is connected to the inverter



**Caution:**

Sunlight hits the panels to create voltage, and high voltages in series can be life-threatening. Therefore, before connecting the DC input line, it is necessary to shield the solar panel with opaque material and put the DC switch in the "OFF" state, otherwise, the high voltage of the inverter may lead to a life-threatening situation.



**Warning:**

Please do not turn off the DC isolator in the presence of high voltage or current. Please use its own DC power connector from the inverter accessories. Do not interconnect the connectors of different manufacturers. Max. DC input current should be 20A. If it exceeds, it may damage the inverter and it is not covered by FelicitySolar warranty.

## 4.2 Battery Connection

Please be careful about any electric shock or chemical hazard. For safe operation and compliance, a separate DC over-current protector or disconnect device is required between the battery and the inverter. In some applications, switching devices may not be required but over-current protectors are still required. Refer to the typical amperage in the table below for the required fuse or circuit breaker size.



• The polarity of battery cannot be connected reversely, otherwise the inverter could be damaged.

Inverter Model	DC Breaker specification	Wire Size	Cable
IVGM3KLP3G2	90A	4AWG	21mm <sup>2</sup>
IVGM4KLP3G2	120A	1AWG	42mm <sup>2</sup>
IVGM5KLP3G2	150A	0AWG	54mm <sup>2</sup>
IVGM6KLP3G2	200A	0AWG	54mm <sup>2</sup>
IVGM8KLP3G2	250A	0AWG	54mm <sup>2</sup>
IVGM10KLP3G2	300A	0AWG	54mm <sup>2</sup>
IVGM12KLP3G2			

**Step 1.** Prepare a suitable battery cable and accessories, and route the battery power cable through the battery cover. Use accessories box accessories, the battery power cable needs to be based on the inverter model. **The recommended wire diameter is single wire diameter.**

**Step 2.** Make battery terminals. Strip cable coat, revealing 15mm length of metal core. Use special crimper to compress battery terminal tightly.

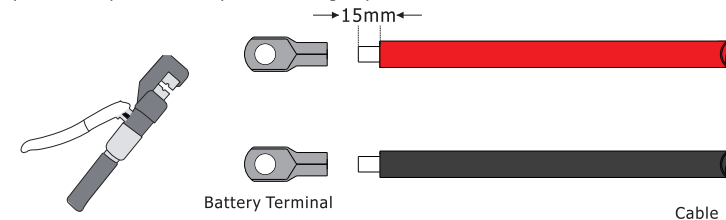
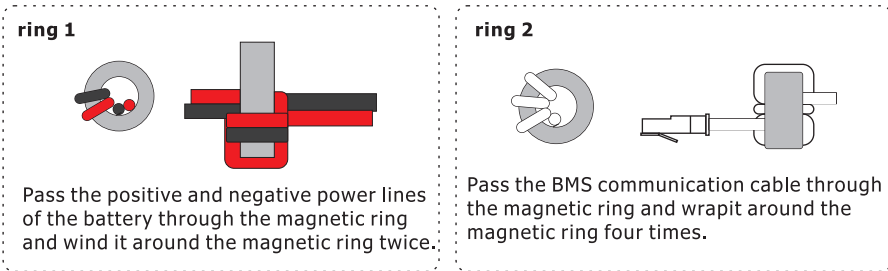
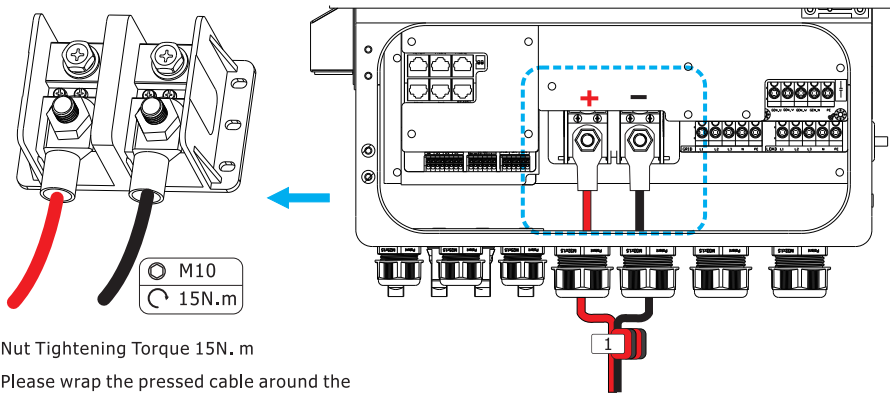

Figure 4.2-1 The battery terminal

**Step 3.** Connect the battery terminal to the inverter. Ensure that the battery polarity is connected correctly.



• Wrap Magnetic Ring 2 and place it outside the inverter cabinet.



Nut Tightening Torque 15N.m

Please wrap the pressed cable around the magnetic ring twice and connect it to the battery terminal of the inverter.

**Figure 4.2-2 The battery terminal is connected to the inverter**

**Warning!** All wiring must be performed by a professional person.  
• The polarity of Battery cannot be connected reversely, otherwise the inverter could be damaged.

### 4.3 Grid, Load and Gen Port Connection

Before connecting to the grid, a separate AC breaker must be installed between the inverter and the grid, and also between the backup load and the inverter. This will ensure the inverter can be securely disconnected during maintenance and fully protected from over current. Check the recommended values in the following tables according to local regulations in each country. The recommended specifications for AC breakers here are based on the Max.Continuous AC passthrough current of inverter, you can also choose the AC breaker of backup side according to the actual total operating current of all the backup loads.

• All wiring must be performed by a qualified personnel.It is very important for system safety and efficient operation to use appropriate cable for AC input connection. To reduce risk of injury, please use the proper recommended cable as below.

#### AC Breaker for backup load

Table 4.3-1 Recommended AC breaker for backup load

Inverter Model	Recommended AC breaker
IVGM12KLP3G2 IVGM10KLP3G2 IVGM8KLP3G2 IVGM6KLP3G2 IVGM5KLP3G2 IVGM4KLP3G2 IVGM3KLP3G2	63A

#### AC Breaker for grid

Table 4.3-2 Recommended AC breaker for grid

Inverter Model	Recommended AC breaker
IVGM12KLP3G2 IVGM10KLP3G2 IVGM8KLP3G2 IVGM6KLP3G2 IVGM5KLP3G2 IVGM4KLP3G2 IVGM3KLP3G2	63A

There are three terminal blocks with "Grid" "Load" and "GEN" markings. Please do not misconnect input and output connectors.

Grid	This works like a conventional arid-tied inverter. It is both an input and outputconnection for non-essential load and supply.
Load	Connection of essential loads such as lighting, security systems, and Internet
Gen	Generator connection



**NOTE:** In final installation, breaker certified according to IEC 60947-1 and IEC 60947-2 shall be installed with the equipment.  
All wiring must be performed by a qualified personnel. It is very important for System safety and efficient operation to use appropriate cable for AC input connection. To reduce risk of injury, please use the proper recommended cable as below. There are two tables below, the first table recommends cable specifications based on bypass current(Max.Continuous AC passthrough), and the second table is based on Max.Three-phase Unbalanced Output Current.

### Grid connection and backup load connection (Copper wires) (bypass)

Table 4.3-3 Grid connection and backup load connection

Inverter Model	Wire Size	Cable(mm <sup>2</sup> )
IVGM12KLP3G2	8AWG	6.0
IVGM10KLP3G2		
IVGM8KLP3G2	10AWG	4.0
IVGM6KLP3G2	12AWG	2.5
IVGM5KLP3G2		
IVGM4KLP3G2	14AWG	1.5
IVGM3KLP3G2	16AWG	1.0



• Be sure that AC power source is disconnected before attempting to wire it to the unit.

### Please follow below steps to implement Grid, load and Gen port connection:

1. Before making Grid, load and Gen port connection, be sure to turn off AC breaker or disconnect first.
2. Peel off the insulation layer of the AC wire by about 12mm and insert the AC lead into the circular hole. Tighten it with a cross-head screwdriver and check if the cable is loose or stuck. Please ensure that the corresponding N wire and PE wire are also connected to the relevant terminals.
3. Make sure all the wires are securely and completely connected.
4. Some appliances, such as air conditioners and refrigerators, may need a time delay before reconnecting them after a power outage. This delay allows the refrigerant gas to stabilize and prevents potential damage. Check if your appliance has a built-in time-delay function before connecting it to our inverter. Examples of appliances that may require a delay include:
  - Air conditioners: Balancing refrigerant gas.
  - Refrigerators: Stabilizing the compressor.
  - Freezers: Allowing the cooling system to balance.
  - Heat pumps: Protecting against power fluctuations.

This inverter will protect your appliances by triggering an overload fault if no time delay is present. However, internal damage may still occur. Refer to the manufacturer's documentation for specific time-delay requirements.

LOAD, GRID, GEN, PE:

Please strip the cables to the dimensions shown in the following picture with professional tools before installation

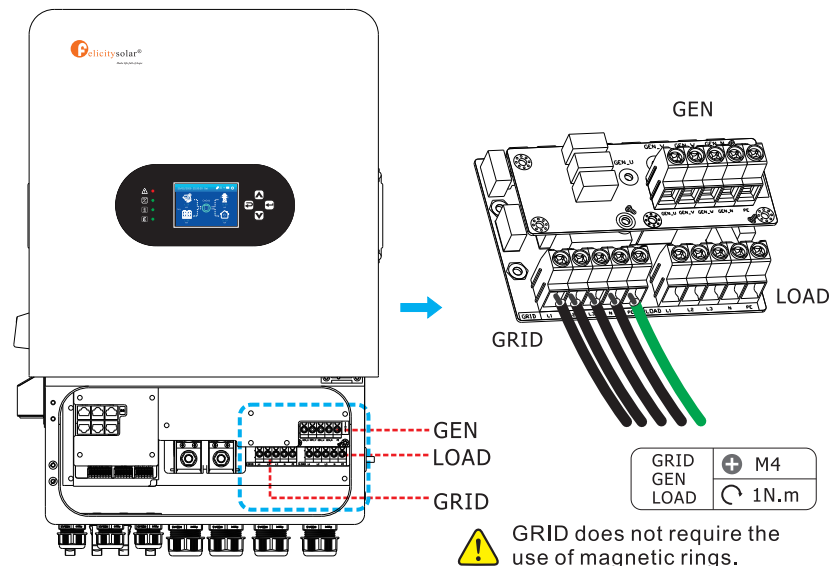

Figure 4.3-1 Gen, Grid, Load and PE port



• All wiring must be carried out by professionals!

### Schematic diagrams of the magnetic rings for LOAD and GEN

#### ring 5

Wind the wire at the load port around the magnetic ring once, and then pass one end of the wire through the magnetic ring. The LOAD terminal and GEN terminal are connected to the inverter according to the silk-screen printing on the chassis.

#### ring 5

Wind the wire of the Gen port around the magnetic ring once, and then pass one end of the wire through the magnetic ring. The load terminals and GEN terminals are connected to the inverter according to the silk-screen printing on the chassis.

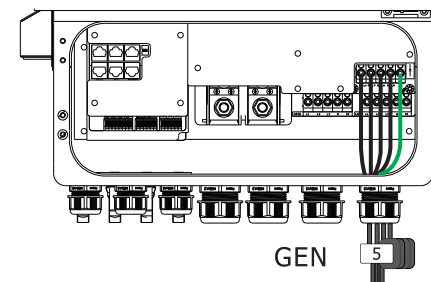
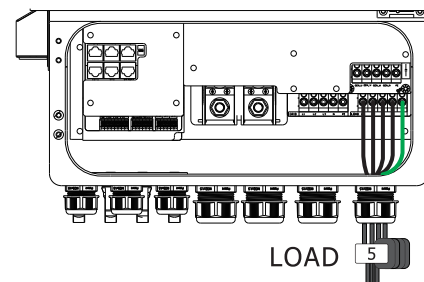

### 4.4 Earth Connection

Ground cable shall be connected to ground plate on grid side, this prevents electric shock if the original protective conductor fails.

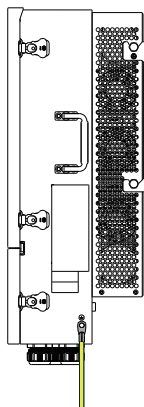

Figure 4.4-1 Earth Connection

The conductor should be made of the same metal as the phase conductors.



**Warning:**

Inverter has built-in leakage current detection circuit. The type A RCD can be connected to the inverter for protection according to the local laws and regulations. If an external leakage current protection device is connected, its operating current must be equal to 10mA/KVA or higher, for this series of inverter it should be 80mA or higher, otherwise inverter may not work properly

### 4.5 Function Port Definition

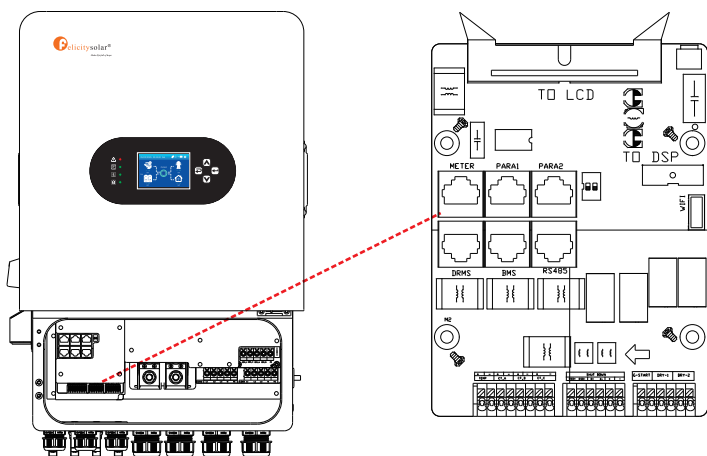

Figure 4.5-1 Function Port Definition

Position	Function
METER	For meter communication(RS485 interface).
PARA1	Parallel communication port1(CAN interface).
PARA2	Parallel communication port2(CAN interface).
DRMS	For Australia market only.
BMS	RS 485 or CAN port for battery communication.
RS485	Reserved



The left side is the BMS switch, and the right side is the parallel switch.

BMS PARA

Turn the DIP switch of the first and last inverter to:ON,and theother machines to OFF.

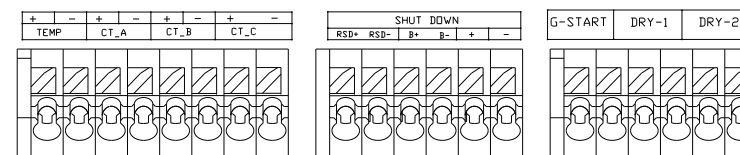

CN3: 1 2 3 4 5 6 7 8 CN5: 1 2 3 4 5 6 CN4: 1 2 3 4 5 6

**CN3**

- (1,2):temperature sensor for lead acid battery.
- (3,4):Current transformer(secondary current of CT are within the range of 10mA-50mA) for Zero Export To CT mode clamps on L1 when in three phase system. Polarity sensitive.
- (5,6):Current transformer(secondary current of CT are within the range of 10mA-50mA) for Zero Export To CT mode clamps on L2 when in three phase system. Polarity sensitive.
- (7,8):Current transformer(secondary current of CT are within the range of 10mA-50mA) for Zero Export To CT mode clamps on L3 when in three phase system. Polarity sensitive.

**CN5**

- (1,2):When battery is connected and the inverter is in "ON" status,it will provide 12Vdc.
- (3,4,5,6):when the terminal "B"&"B" is short-circuited with additional wire connection,or there's 12Vdc input at the terminal"+&-" ,then the12Vdc of RSD+&RSD-will disappear immediately,and the inverter will shutdown immediately.

**CN4**

- (1,2):dry contact signal for startup the diesel generator.When the "GEN signal" is inactive,the open contact(GS)will switch on(no voltage output).
- (3,4,5,6):reserved.

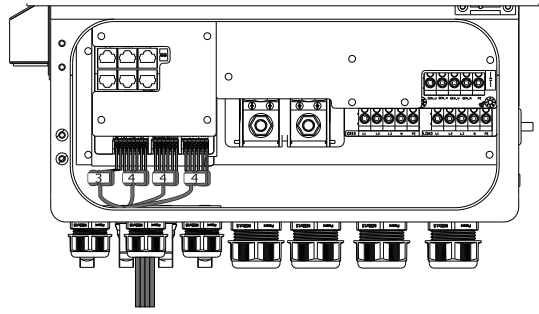

• Wrap Magnetic Ring 3 and Magnetic Ring 4 and place them outside the inverter cabinet.

Ring	Function port	Installation instructions
3	TEMP:CN3(1,2)	Wrap the wires three laps around the magnetic ring, then thread the end of wires through the magnetic ring.
4	CT:CN3(3,4,5,6,7,8)	Wrap the wires three laps around the magnetic ring, then thread the end of wires through the magnetic ring.
4	RSD:CN5(1,2,3,4,5,6)	Wrap the wires three laps around the magnetic ring, then thread the end of wires through the magnetic ring.
4	Dry Contact:CN4(1,2,3,4,5,6)	Wrap the wires three laps around the magnetic ring, then thread the end of wires through the magnetic ring.

### 4.6 Smart Meter Connection(Reserve)

The Smart Meter is optional for IVGM system installation, used to detect grid voltage and current direction and magnitude, further to instruct the operation condition of IVGM inverter via RS485 communication.

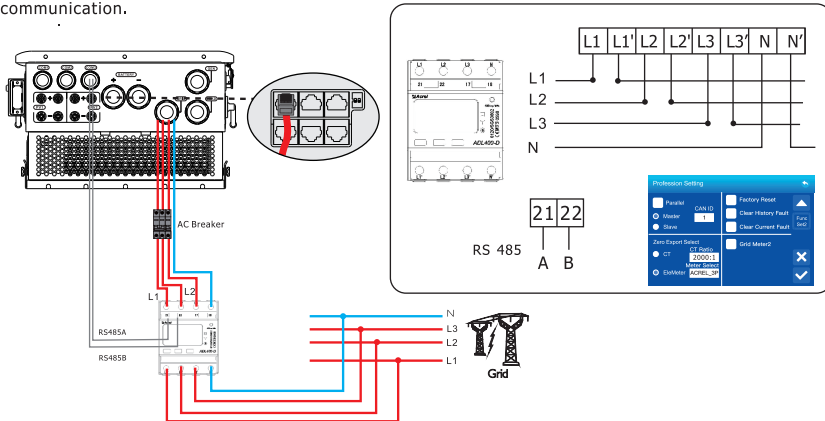

Figure 4.6-1 Smart meter connection(Three-phase)

If two electricity meters are connected, the RS485 lines of the two meters should be connected in parallel. The address of the inverter electricity meter should be set to 1, and the address of the micro-reverse electricity meter should be set to 2.

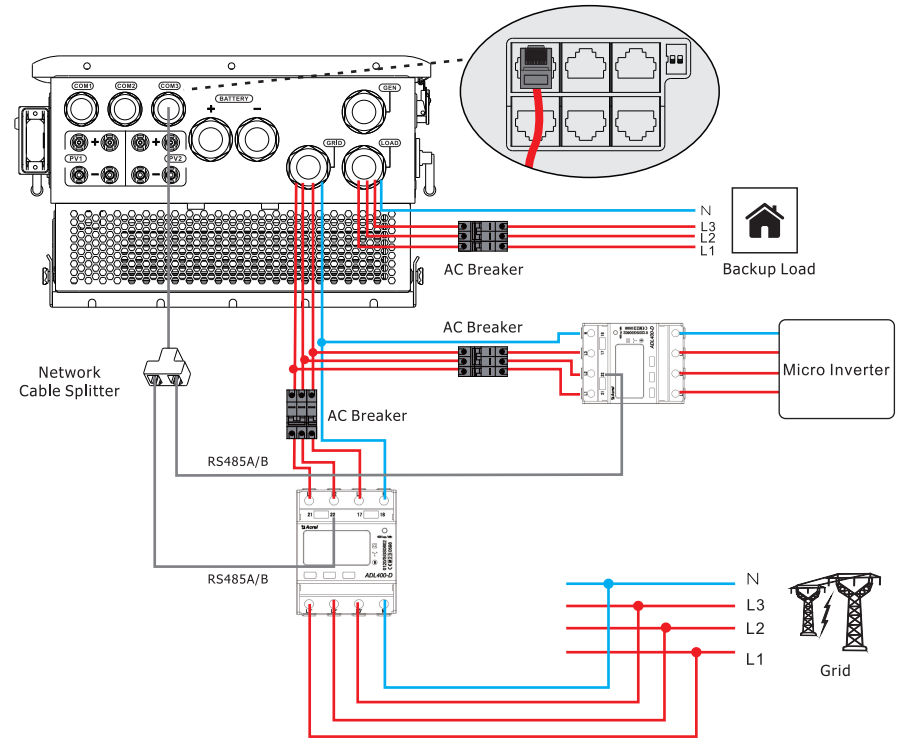

Figure 4.6-2 Smart meter connection(Three-phase)

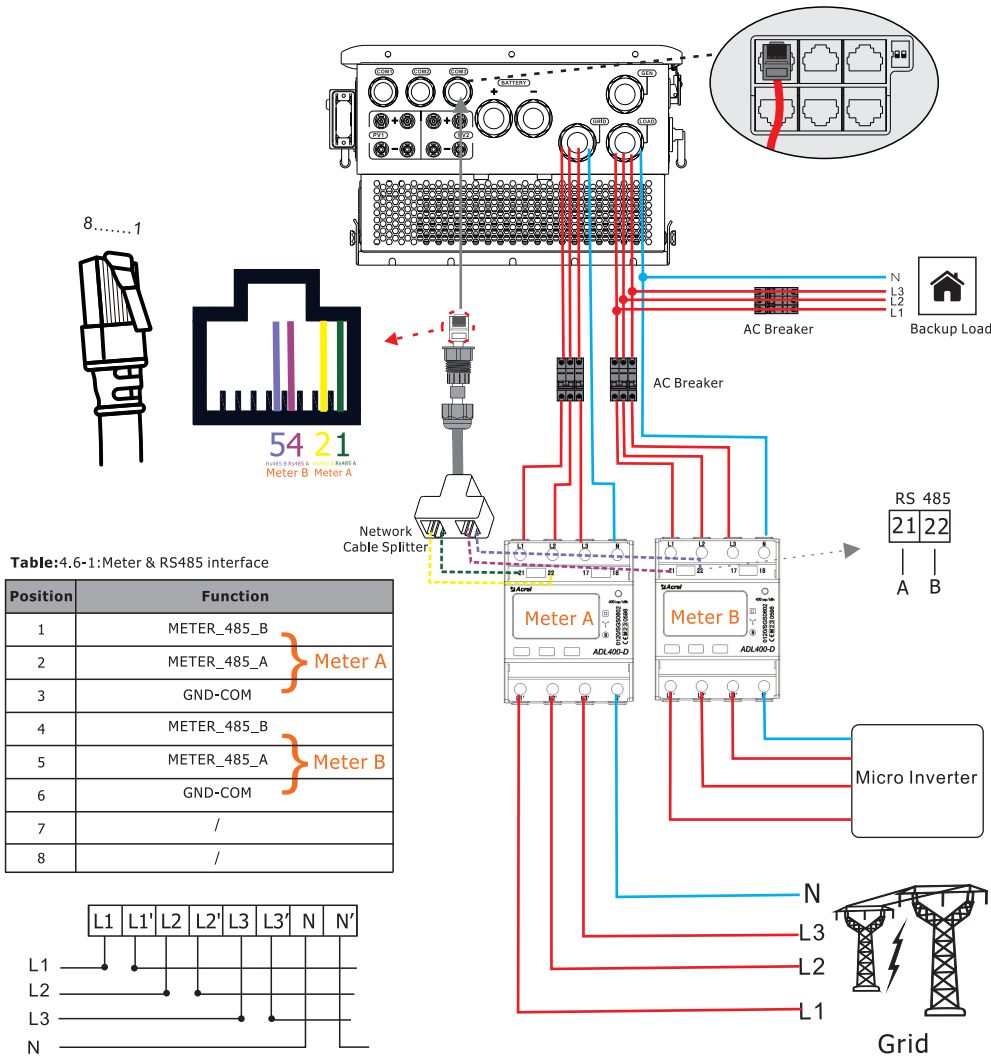
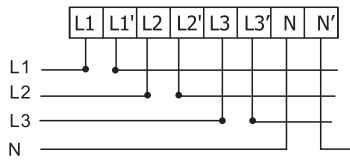

Table 4.6-1: Meter & RS485 interface

Position	Function
1	METER_485_B
2	METER_485_A
3	GND-COM
4	METER_485_B
5	METER_485_A
6	GND-COM
7	/
8	/



**Profession Setting**

Parallel     CAN ID     Factory Reset  
 Master    CAN ID: 10     Clear History Fault      
 Slave  
 Zero Export Select     Grid Meter2  
 CT    CT Ratio: 2000:1     Force Off Grid  
 Meter Select: ACREL\_3P  
 EleMeter: ACREL\_3P

**Gen Port Setting**

Gen:  Generator Input     Micro Inv Input  
 Rated Power: 6000W     On Grid Side      
 On Load Side  
 Gen Peak Shaving    Start: 80%  
 Gen Connect To Grid    Exit: 90%  
 Of-Freq: 5.5, 00Hz   

Figure 4.6-3 Smart meter connection(Three-phase)

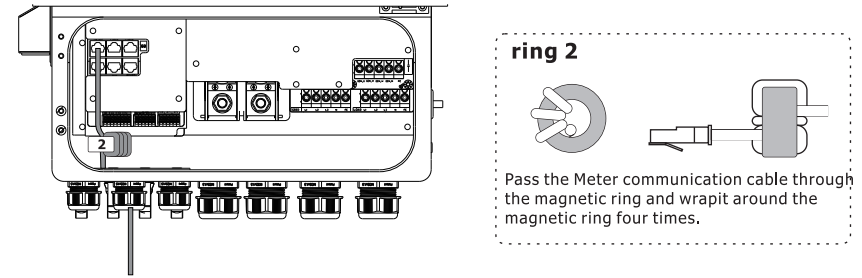

• Wrap Magnetic Ring 2 and place it outside the inverter cabinet.

### 4.7 CT Connection

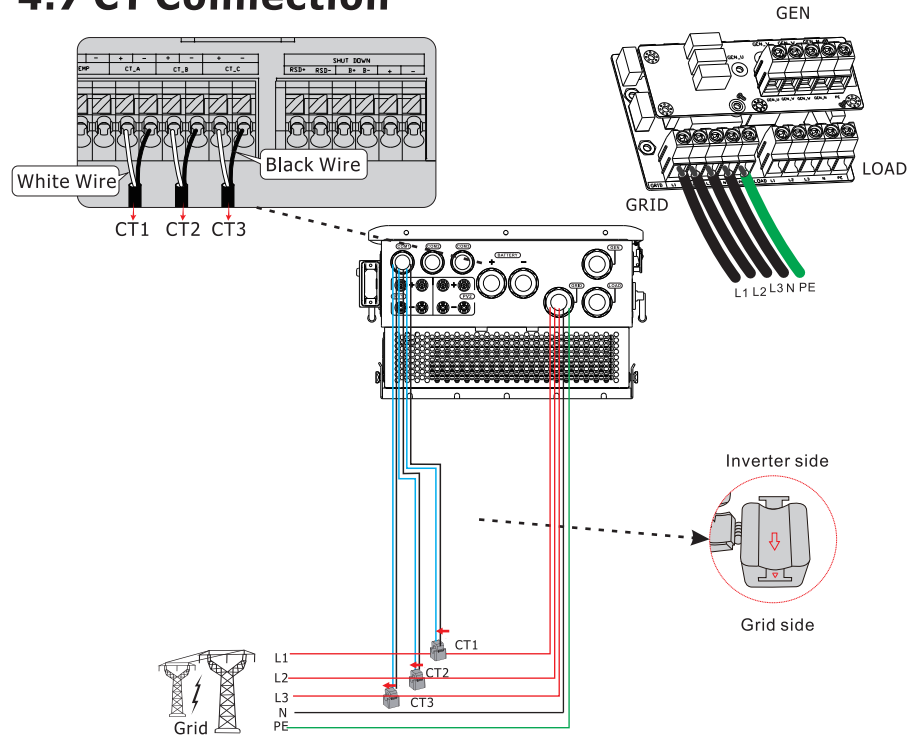

Figure 4.7-1 CT connection

- CT1(+/-):** Current transformer (CT1) for "zero export to CT" mode clamps on L1 when in three phase system.
- CT2(+/-):** Current transformer (CT2) for "zero export to CT" mode clamps on L2 when in three phase system.
- CT3(+/-):** Current transformer (CT3) for "zero export to CT" mode clamps on L3 when in three phase system.

## 4.8 DRMS Connection

DRMS(Demand Response Modes) is used for Australia and New Zealand and installation (also used as remote shutdown function in European countries), in compliance with Australia and New Zealand safety requirements( or European countries). Inverter integrates control logic and provides an interface for DRMS. The DRMS is not provided by inverter manufacturer. Detailed connection of DRMS & Remote Shutdown are shown below:

**Step 1.** Open the latch from the right side of the machine. See Figure 4.8-1.

**Step 2.** Plug out the RJ45 terminal and dismantle the resistor on it. Plug the resistor out, leave the RJ45 terminal for next step.

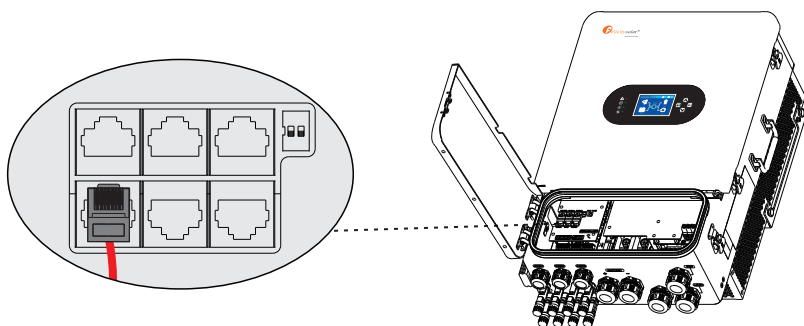

Figure 4.8-1 DRMS interface

**NOTE**

•The RJ45 terminal in the inverter has the same function as DRED. Please leave it in the inverter if no external device is connected.

**Step 3-1** Pass the RJ45 cable through the steel plate and connect the DRED cable to the RJ45 terminal. As shown in Figure 4.8-2, Table 4.8-3 describes the 6-pin port definition.

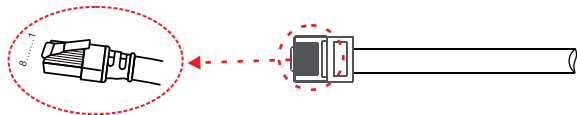

Figure 4.8-2 operating steps

Table 4.8-1 :Port pin allocation table

NO.	1	2	3	4	5	6	7	8
Function	DRM1/5	DRM2/6	DRM3/7	DRM4/8	REF	COM	/	/

**Step 3-2** For Remote Shutdown. Run the cable through the steel plate , Then wire from pins 5 and 6. Table 4.5-1 describes the 6-pin port definition,Wiring is shown in Figure 4.8-3

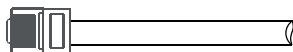

Figure 4.8-3 Remotely close the cable connection

**Step 4.** Connect RJ45 terminal to the right position onto the inverter.See Figure 4.8-4

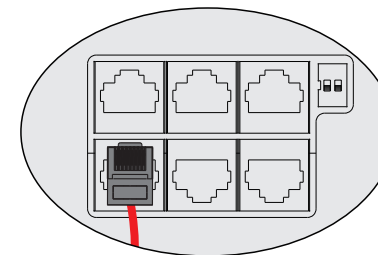

Figure 4.8-4 RJ45 interface

## 4.9 Lithium Battery Communication

It's allowed to connect lithium battery and build communication only which it has been configured, Please follow bellow steps to configure communication between lithium battery and inverter.

1. Connect power cables between lithium battery and inverter, Please pay attention to the terminals of positive and negative. Make sure the positive terminal of battery is connected to the positive terminal of inverter, and the negative terminal of battery is connected to the negative terminal of inverter.
2. The communication cable is bundled with lithium battery, Both sides are RJ45 port. One port is connected to the BMS port of inverter and another one is connected to the PCSport of lithium battery.

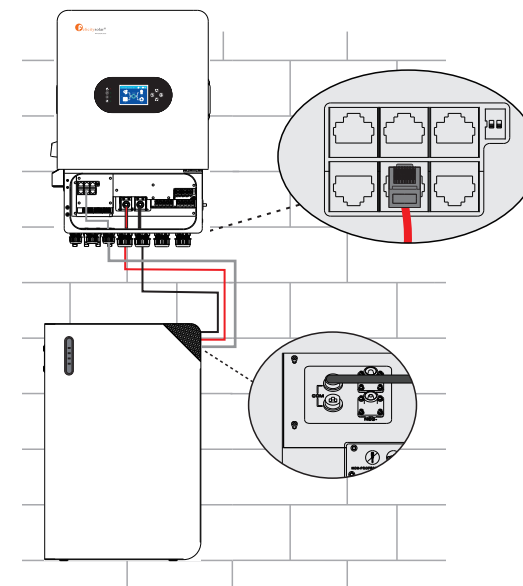
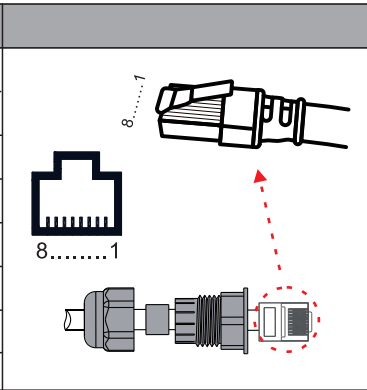

Table 4.9-1 :Detailed Pin Function Of BMS Port On IVGM

Position	Function
1	/
2	/
3	BMS_L
4	BMS_H
5	BMS_485B
6	BMS_485A
7	/
8	/



### 4.10 Installation of WIFI module

The WiFi communication function applies only to the WiFi module. For details, see Figure 4.10-1 installing a WiFi module.

When installing the Wi-Fi module, use the long screws provided in the Wi-Fi kit.

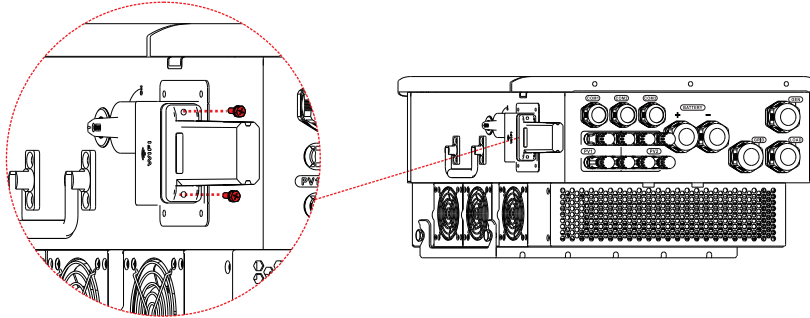
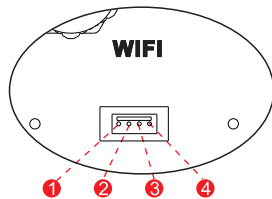

Figure 4.10-1 WiFi Module installation

Table 4.10-1 : WiFi Module installation Table

NO.	1	2	3	4
Function	VCC	GND	WiFi/232RX	WiFi/232TX



### 4.11 Wire System For Inverter

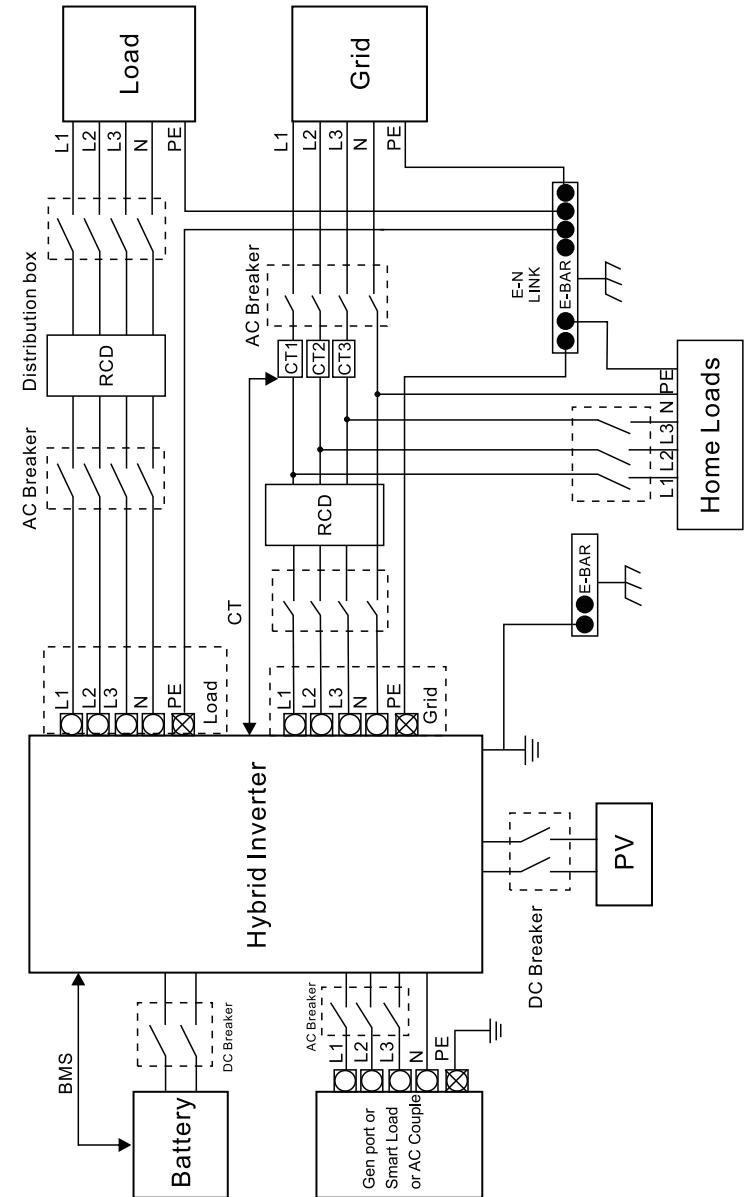

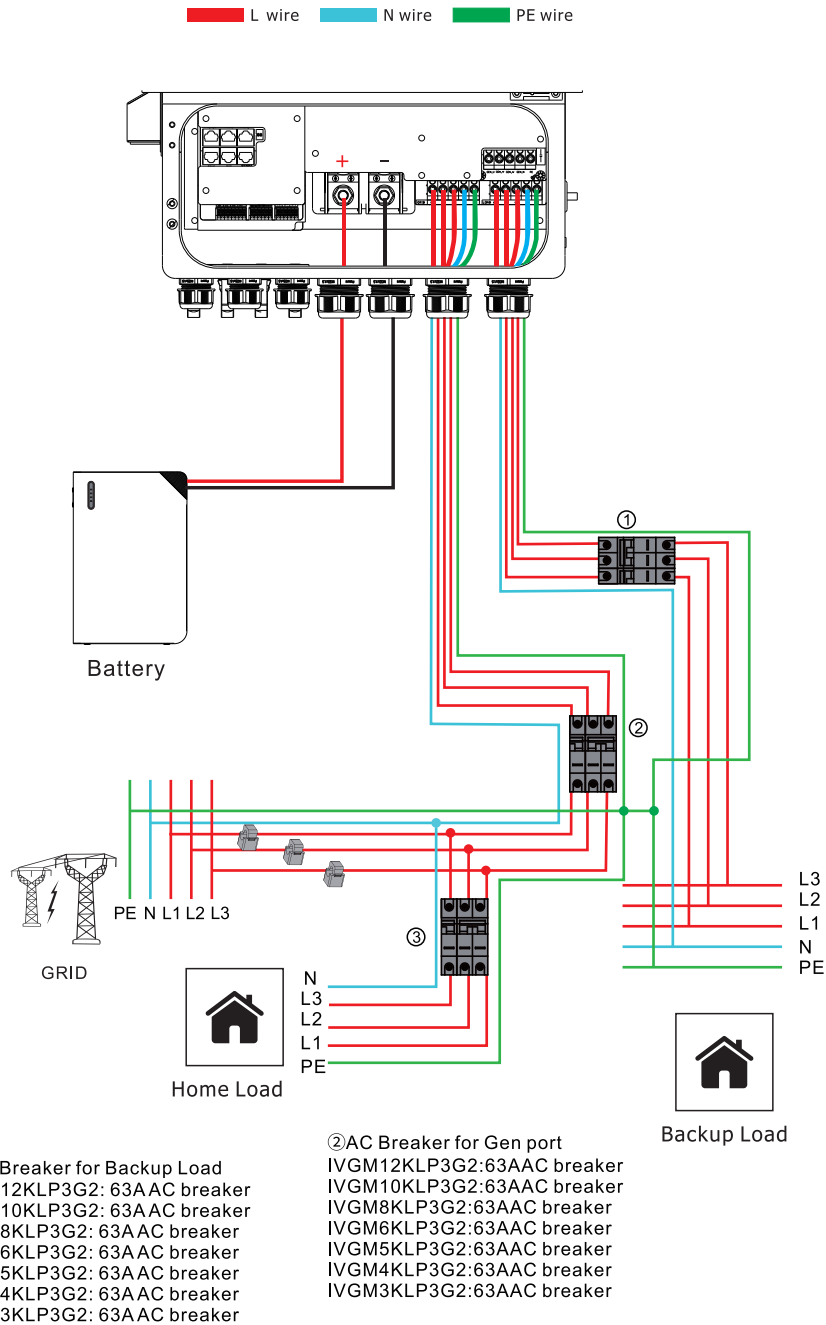

### 4.12 Typical Application Diagram of Diesel Generator

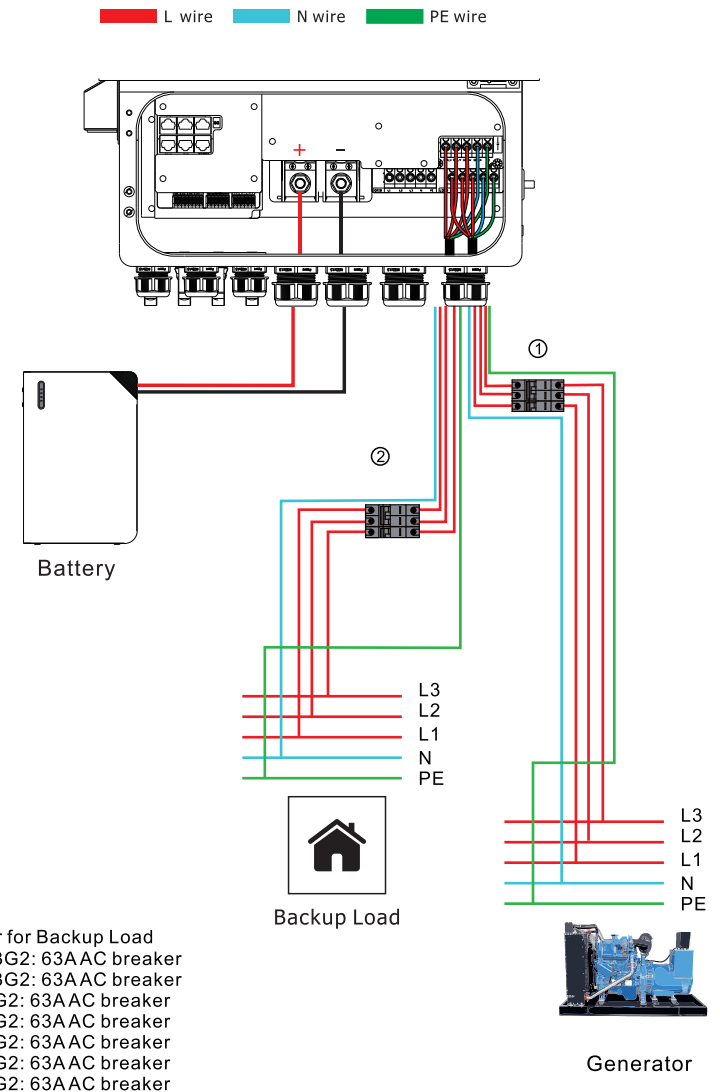

### 4.13 Three Phase Parallel Inverter

CAN L wire N wire PE wire

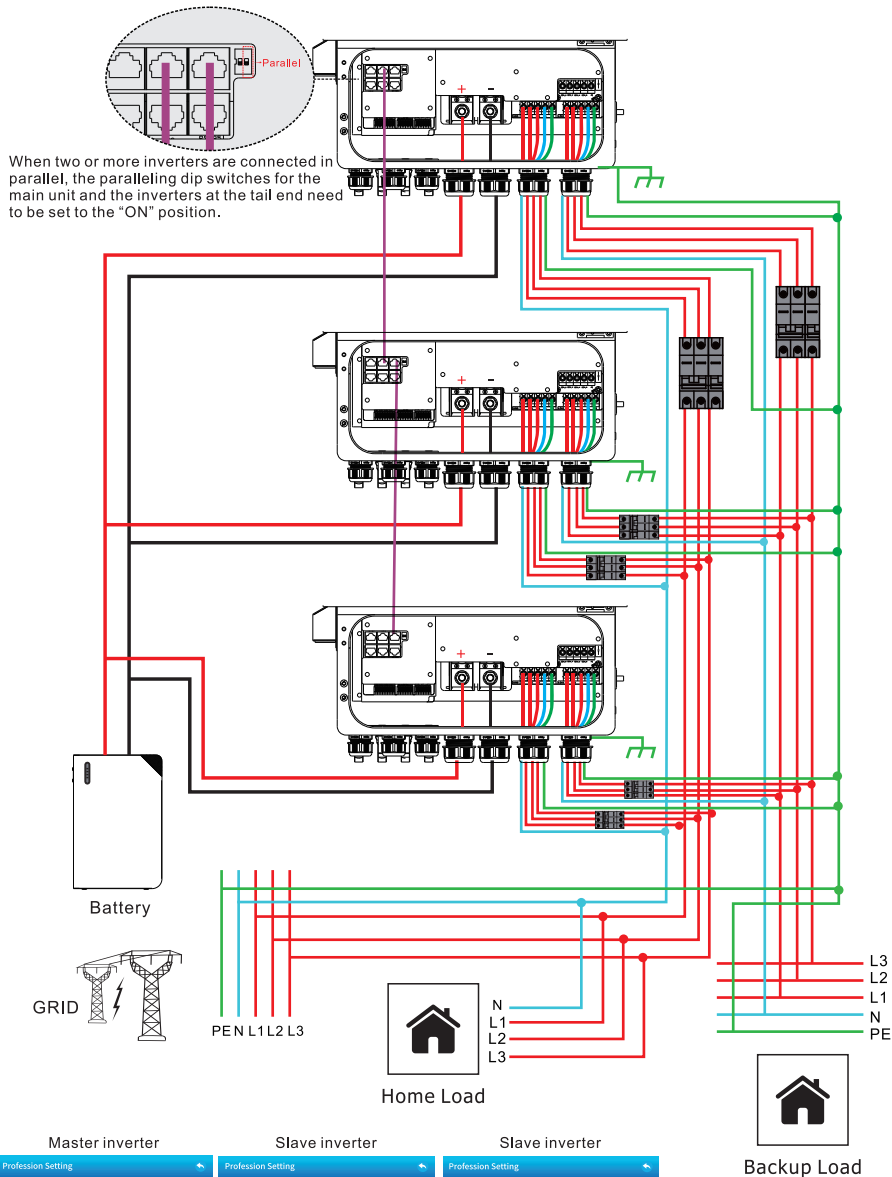

Master inverter		Slave inverter		Slave inverter	
Profession Setting					
<input checked="" type="checkbox"/> Parallel	Factory Reset	<input checked="" type="checkbox"/> Parallel	Factory Reset	<input checked="" type="checkbox"/> Parallel	Factory Reset
<input checked="" type="radio"/> Master	Clear History Fault	<input checked="" type="radio"/> Master	Clear History Fault	<input checked="" type="radio"/> Master	Clear History Fault
<input checked="" type="radio"/> Slave	Clear Current Fault	<input checked="" type="radio"/> Slave	Clear Current Fault	<input checked="" type="radio"/> Slave	Clear Current Fault
Auto Export Select	Grid Meter2	Auto Export Select	Grid Meter2	Auto Export Select	Grid Meter2
<input checked="" type="radio"/> CT	Force Off Grid	<input checked="" type="radio"/> CT	Force Off Grid	<input checked="" type="radio"/> CT	Force Off Grid
<input checked="" type="radio"/> No Meter		<input checked="" type="radio"/> No Meter		<input checked="" type="radio"/> No Meter	

**Note:**  
When using CT, check the CT option and set the CT ratio;  
When using the electricity meter, check the electricity meter option.

## 5. Display and Operation

This chapter describes the panel displaying and how to operate on the panel, which involves the LCD display, LED indicators and operation panel.

### 5.1 Inverter Power ON/OFF



TURN ON the inverter with at least one of the following power sources:  
1 Battery, 2 PV, 3 Grid/Generator.

#### 5.1.1 Pre-Commissioning

- Make sure that no high voltage conductors are energized.
- Check all conduit and cable connection points ensure they are tight.
- Verify that all system components have adequate space for ventilation.
- Follow each cable to ensure that they are all terminated in the proper places.
- Verify that the inverter is secured to the wall and is not loose or wobbly.

#### 5.1.2 Inverter Power ON

- Step 1:** With the DC switch off, energize the PV strings and then measure DC voltage of the PV strings to verify that the voltage and polarity are correct. Turn on the battery and check the battery voltage and polarity as well.
- Step 2:** Turn on the AC breaker for the system and then measure the AC voltages line to line and line to neutral. The backup side of the system will be off until commissioning is complete. Turn the AC breaker back off for now.
- Step 3:** Turn the battery breaker on, the DC switch and then the AC breaker for the system, **press the Power ON/OFF button to turn on the unit.**  
This inverter can be powered on by PV only, battery only and Grid only.

#### 5.1.3 Inverter Power OFF

- Step 1:** Press the Power ON/OFF button to turn off.
- Step 2:** Turn off the AC breaker to disable AC power to the inverter.
- Step 3:** Turn off the DC switch of the inverter.
- Step 4:** Turn off the battery breaker.
- Step 5:** Use a multimeter to verify that the battery and AC voltages are 0V.

## 5.2 Operation and Display Panel

Once the unit has been properly installed and the batteries are connected well, simply press ON/OFF button (located on the left side of the case) to turn on the unit. When system without battery connected, but connect with either PV or grid, and ON/OFF button is switched off, LCD will still light up (Display will show Standby), In this condition, when switch on ON/OFF button and select NO battery, system can still working.



Table 5.2-1 LED indicators

Number	LED Indicator	Messages	
1	Fault	Red led solid light	Fault
2	DC/AC	Green led solid light	Inverter operation normal
3	GRID	Green led solid light	Grid connection normal
4	BATTERY	Green led solid light	Battery connection normal

Table 5.2-2 Function Buttons

Function Key	Description
Esc	To exit setting mode
Up	To go to previous selection
Down	To go to next selection
Enter	To confirm the selection

## 5.3 LCD Display Icons

The LCD is touchscreen, below screen shows the overall information of the inverter.

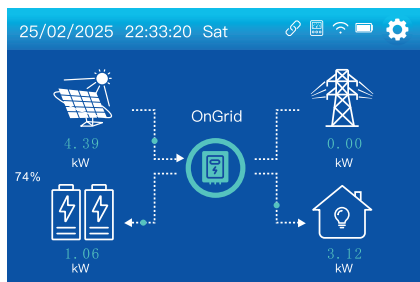

1. The icon in the center of the home screen indicates that the system is Normal operation. If it turns into red and shows "fault", it means the inverter has errors. If it turns into yellow, it means the inverter has warning. And the error or warning message will display under this icon (detail info can be viewed in the System Alarms menu).

2. At the top of the screen is the time (day/month/year,time).

3. System Setup Icon, Press this set button, you can enter into the system setup screen which including Basic Setting, Battery Setting, Grid Setting, Work Mode Setting, Gen setting, Profession Setting and Alarm Info.

4. The main screen showing the info including Solar, Grid, Load and Battery. Its also displaying the energy flow direction by arrow.

- PV power and Load power always keep positive.
- Grid power negative means sell to grid, positive means get from grid.
- Battery power positive means charge, negative means discharge.

## 5.4 Power Curve

	<p><b>This is Solar Panel detail page.</b> Press the "Energy" button will enter into the power curve page.</p> <p>① Solar Panel Generation. ② Voltage, Current, Power for each MPPT. ③ Daily and total PV production.</p>															
<table border="1"> <thead> <tr> <th>PV</th> <th>Battery</th> <th>Gen</th> </tr> </thead> <tbody> <tr> <td>0.0V 0.0V 0.0A 0.0A 0.00kW 0.00kW</td> <td>52.4V 0.0A 0.00kW</td> <td>0.0V 0.0A 0.0V 0.0A 0.0V 0.0A</td> </tr> <tr> <th>Grid</th> <th>Inverter</th> <th>Backup Load</th> </tr> <tr> <td>0.00kW 49.98Hz</td> <td>0.00kW 0.00Hz</td> <td>0.00kW 0.00Hz 0.00kW</td> </tr> <tr> <td>230.0V -0.8A 229.8V -0.7A 229.8V 1.0A Grid_P: CT_I: INV_P: Envi: 0.00kW 0A 2.19kW 34C 0.00kW 0A 2.19kW SINK: 0.00kW 0A 2.19kW 37C</td> <td>230.0V 9.5A 229.9V 9.6A 229.8V 9.6A</td> <td>6.58kW 230.0V 2.19kW 228.7V 2.19kW 229.9V 2.20kW</td> </tr> </tbody> </table>	PV	Battery	Gen	0.0V 0.0V 0.0A 0.0A 0.00kW 0.00kW	52.4V 0.0A 0.00kW	0.0V 0.0A 0.0V 0.0A 0.0V 0.0A	Grid	Inverter	Backup Load	0.00kW 49.98Hz	0.00kW 0.00Hz	0.00kW 0.00Hz 0.00kW	230.0V -0.8A 229.8V -0.7A 229.8V 1.0A Grid_P: CT_I: INV_P: Envi: 0.00kW 0A 2.19kW 34C 0.00kW 0A 2.19kW SINK: 0.00kW 0A 2.19kW 37C	230.0V 9.5A 229.9V 9.6A 229.8V 9.6A	6.58kW 230.0V 2.19kW 228.7V 2.19kW 229.9V 2.20kW	<p><b>This is Inverter detail page.</b></p> <p>① DC/AC inverter module Voltage, Current, Power for each Phase. SINK: mean Heat-sink temperature.</p>
PV	Battery	Gen														
0.0V 0.0V 0.0A 0.0A 0.00kW 0.00kW	52.4V 0.0A 0.00kW	0.0V 0.0A 0.0V 0.0A 0.0V 0.0A														
Grid	Inverter	Backup Load														
0.00kW 49.98Hz	0.00kW 0.00Hz	0.00kW 0.00Hz 0.00kW														
230.0V -0.8A 229.8V -0.7A 229.8V 1.0A Grid_P: CT_I: INV_P: Envi: 0.00kW 0A 2.19kW 34C 0.00kW 0A 2.19kW SINK: 0.00kW 0A 2.19kW 37C	230.0V 9.5A 229.9V 9.6A 229.8V 9.6A	6.58kW 230.0V 2.19kW 228.7V 2.19kW 229.9V 2.20kW														

<p>Load</p> <p>Pa_Load Pa_Home:0.00kW Pa_Sum :0.07kW          Pb_Load Pb_Home:0.00kW Pa_Sum :0.04kW          Pc_Load Pc_Home:0.00kW Pa_Sum :0.08kW          Psum_Load:0.19kW Psum_Home:0kW Psum:0.19kW          Va: 229.8V Today : 9.9kWh          Vb: 229.5V Total :37.1kWh          Vc: 229.5V</p> <p>Energy</p>	<p><b>This is Load detail page.</b>          Press the "Energy " button will enter into the power curve page.          ① Pa_load/Pb_load/Pc_load: the phase A/B/C power at the backup port          P_sum_load: the total power at the Backup interface;          Pa_Home/Pb_Home/Pc_Home: the home load power connected to the grid,          Psum_home: the total home load power;          Pa_sum/Pb_sum/Pc_sum: the total power connected to each phase, which equals the Backup power plus the home load power.  <math>P\_sum = P\_sum\_load + Psum\_home;</math>          ② Va/Vb/Vc: Voltage for each Phase</p>
<p>Grid</p> <p>Va: 0.0V Pa: 0.00kW Pa_CT: 0.00kW          Vb: 0.0V Pb: 0.00kW Pb_CT: 0.00kW          Vc: 0.0V Pc: 0.00kW Pc_CT: 0.00kW          F: 0.00Hz Psum: 0.00kW P_CTsum: 0.00kW</p> <p>SELL BUY          Today : 0.9kWh Today : 2.8kWh          Total : 7.8kWh Total : 3.8kWh</p> <p>Energy</p>	<p><b>This is Grid detail page.</b>          ① Va/Vb/Vc: Voltage for each Phase          Pa_CT/Pb_CT/Pc_CT: Power detected by the external current sensors.          Pa/Pb/Pc: Power detected using internal sensors on AC grid in/out breaker.          Pa_CT/Pa_CT/Pa_CT: represent the power flowing through the power grid CTa, CTb, and Ctc          PCT_sum: the total power of the CT.          ② BUY: Energy from Grid to Inverter.          SELL: Energy from Inverter to grid.</p>

### 5.5 Basic Setting

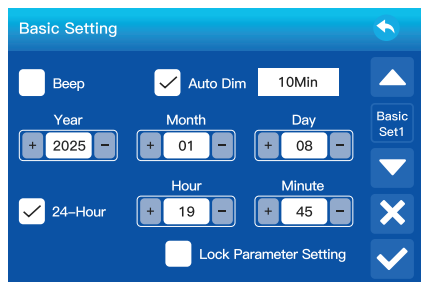

**Beep:** Used to turn on or off the beep sound in inverter's alarm status.

**Lock Parameter Setting:** All setting parameters cannot be set up when it is active.

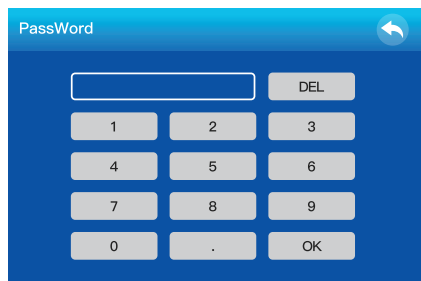

**Lock Parameter Setting Password:** 123456

**Auto Dim:**The backlight of LCD will power off after the set time.

### 5.6 Battery Setting

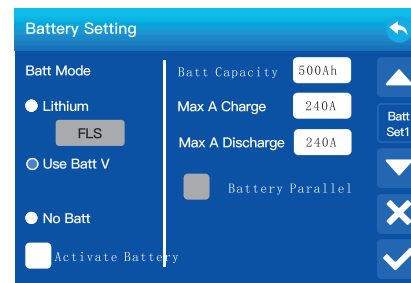

**Batt Capacity:** Reserved.

**Lithium:** Use SOC for all battery related settings.

**Lithium Mode:** This is the BMS communication protocol code which can be confirmed on the "Felicity Solar Approved Battery list " base on the battery model you are using.

**Use Batt V:** Use battery voltage for all battery related settings.

**No Batt:** tick this item if no battery is connected to the system.

**Max A Charge/Discharge:**Max battery charge/dischargecurrent(0-240A for 12kW model,0-210A for 10kW model,0-190A for 8kW model,0-135A for 6kW model,0-120A for 5kW model,0-95A for 5kW model,0-75A for 3kW model)

• For AGM and Flooded, we recommend Ah battery size  $x20\% = \text{Charge/Discharge amps}$ .

• For Lithium, we recommend Ah battery size  $x50\% = \text{Charge/Discharge amps}$ .

• For Gel, follow manufacturer' s instructions.

**Active Battery:** This feature will help recover a battery that is over discharged by slowly charging from the solar array or grid.

**Battery Parallel:** Reserved

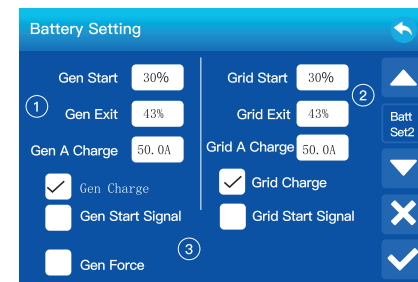

**This is Battery Setup page.** ①③

**Gen Start :** Percent SOC below 30% system will Auto Start a connected generator to charge the battery bank.

**Gen Exit:**When the battery SOC or voltage reaches a preset Gen exit point, the inverter will disconnect the generator.

**Gen A Charge:** The maximum charging current that the generator can support.

**Gen Charge:** Use the power of diesel generator to charge the battery.

**Gen Start Signal:** The normally open relay will close when the battery SOC or voltage drop to the set value of "Start"

**Gen Force:** When the generator is connected, it is forced to start the generator without meeting other conditions.

### This is Grid Charge, you need select. ②

**Grid Start :** When battery SOC or voltage drop to this set value, inverter will start the generator connected to the grid port automatically to charge the battery.

**Grid Exit:**Reserve

**Grid A Charge:** maximum charging current when only use the power fed from the grid port of inverter as the power source, which means using the power of grid or the power of generator connected to the grid port.

**Grid Charge:** It's allowed to use power fed from the grid port, which includes grid or generator connected to the grid port, to charge the battery.

**Grid Start Signal:** When a generator is connected to the grid port of hybrid inverter, this 'Grid signal' can be used to control the dry contact to start or stop the generator.

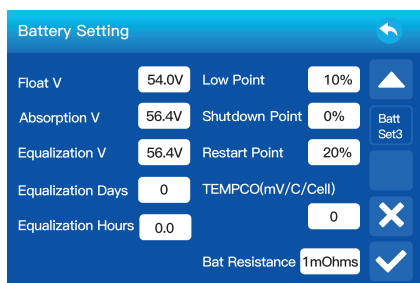

**Float V:** The long-term maintenance stage after the battery is fully charged. The core purpose is to replenish the power lost by self-discharge with a small current to maintain the battery in a fully charged state, while minimizing the risk of overcharging to the greatest extent. It is recommended that the voltage be set between 54V and 55V.

**Absorption V:** When the battery voltage reaches the preset value, the charging switch is to a constant voltage output, and the current gradually decreases. It is recommended to set the voltage between 56.4V and 57.6V.

**Equalization V:** Equalization charging is not part of the regular charging cycle. It is designed to address the issue of inconsistent voltages among individual cells in a battery pack. It can be manually initiated or automatically executed by the charger on a monthly or quarterly basis. It is recommended to set the voltage between 56.4V and 59V.

**Equalization Days:** The equalization charging interval days refer to the time interval between two automatic equalization charges. It needs to be adjusted according to the battery usage intensity and environment. It is recommended to do it once every 15 to 90 days. Lithium batteries do not support this mode.

**Equalization Hours:** It is recommended to set the equalization charging duration to 0-12 hours. Lithium batteries do not support this mode.

**TempCo:** Temperature has a significant impact on the float voltage of lead-acid batteries, and temperature compensation is required.

## 5.7 Work Mode Setting

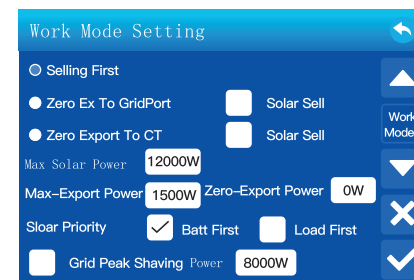

**Selling First:** This Mode allows hybrid inverter to sell back any excess power produced by the solar panels to the grid. If Time Of Use is active, the battery energy also can be sold into grid. The PV energy will be used to power the load and charge the battery and then excess energy will flow to grid.

Power source priority for the load is as follows:

1. Solar Panels.
2. Grid. when Energy Pattern tick Batt First.  
Battery (until programmable SOC discharge is reached). when Energy Pattern tick Load First and disable Grid charge.

**Max Solar Power:** the maximum DC input power allowed.

**Zero Ex To GridPort:** Hybrid inverter will only provide power to the backup load connected. The hybrid inverter will neither provide power to the home load nor sell power to grid. The built-in CT will detect power flowing back to the grid and will reduce the power of the inverter only to supply the backup load and charge the battery.

In this mode, the standard CT needs to be connected.

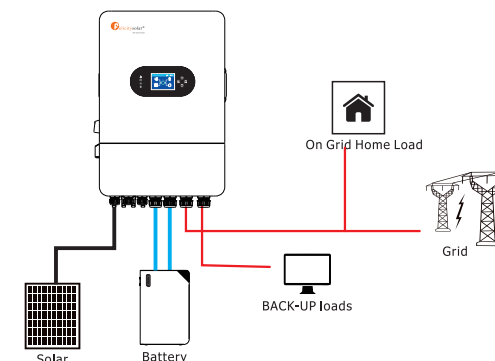

**Zero Export To CT:** Hybrid inverter will not only provide power to the backup load connected but also give power to the home load connected. If PV power and battery power is insufficient, it will take grid energy as supplement. The hybrid inverter will not sell power to grid. In this mode, a CT is needed. The installation method of the CT please refer to Table 4.7 CT Connection. The external CT will detect power flowing back to the grid and will reduce the power of the inverter only to supply the backup load, charge battery and home load.

In this mode, the standard CT needs to be connected.

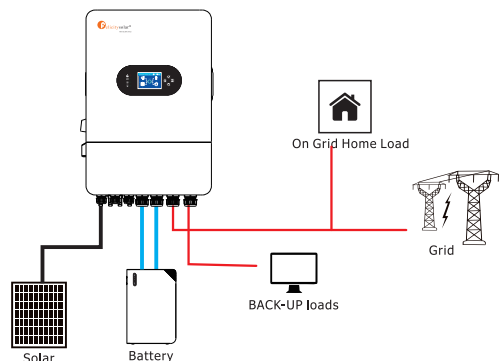

**Solar Sell:** "Solar sell" is supplement for Zero Ex To GridPort or Zero Export To CT: when this item is active, the surplus PV energy can be sold back to grid too. When it is active, PV Power source priority usage is as follows: load consumption and charge battery and feed into grid.

**Max-Export Power:** Allowed the maximum output power to flow to grid.

**Zero-export Power:** For zero-export mode, it tells the grid output power. Recommend to set it as 20-100W to ensure the hybrid inverter won't feed power to grid.

**Solar Priority:** Priority of PV power usage.

**Batt First:** PV power is firstly used to charge the battery and then used to power the load. If PV power is insufficient, grid will make supplement for battery and load simultaneously.

**Load First:** PV power is firstly used to power the load and then used to charge the battery. If PV power is insufficient, Grid will provide power to load, but neither the battery power to load nor the Grid charge to battery.

### Grid Peak Shaving:

1. To use Peak-Shaving on a generator, the equipment MUST be connected to the "GRID" terminal of the inverter.
2. Peak-Shaving helps reduce grid consumption during peak demand by utilizing battery backup power. It can also be used to prevent generator overload above a specified power threshold.
3. Install the CT sensors on grid / generator lines L1, L2, L3. The arrows on the CTs must point toward the GRID.
4. The IVGM INVERTER supplies power from the batteries whenever the "Power" threshold is met.
5. This mode will automatically adjust the "Grid Charge" amperage (A) to avoid generator overloads during battery charging.
6. Grid Peak-Shaving will automatically enable "Time of Use" and must be configured.

Work Mode Setting						
Grid Chg	Gen Chg	Sell	Pv Off	Time1	Time2	Power
<input checked="" type="checkbox"/>	<input type="checkbox"/>	<input type="checkbox"/>	<input type="checkbox"/>	00:00	08:00	4000W
<input checked="" type="checkbox"/>	<input type="checkbox"/>	<input type="checkbox"/>	<input type="checkbox"/>	08:00	12:00	4000W
<input checked="" type="checkbox"/>	<input type="checkbox"/>	<input type="checkbox"/>	<input type="checkbox"/>	12:00	14:00	4000W
<input type="checkbox"/>	<input type="checkbox"/>	<input type="checkbox"/>	<input type="checkbox"/>	14:00	18:00	4000W
<input type="checkbox"/>	<input checked="" type="checkbox"/>	<input type="checkbox"/>	<input type="checkbox"/>	18:00	21:00	4000W
<input checked="" type="checkbox"/>	<input checked="" type="checkbox"/>	<input type="checkbox"/>	<input type="checkbox"/>	21:00	00:00	4000W

**Time Of Use:** it is used to program when to use grid or generator to charge the battery, and when to discharge the battery to power the load. Only tick "Time Of Use" then the follow items (Grid, charge, time, power etc.) will take effect.

**Note:** when tick Selling First and click Time Of Use, the battery power can be sold into grid. Charge Source: select grid or diesel generator to charge the battery.

**GridChg:** Use grid to charge the battery in a time period.

**GenChg:** Use diesel generator to charge the battery in a time period.

**Note:** If tick Grid and Gen at the same time, Grid is priority. and only the Gen Charge Enable or Grid Charge Enable is tick in Battery Setting, can the corresponding Gen or Grid tick take effect.

**Sell:** During the specified time period, PV and battery energy are prioritized for sale to the grid. (Only effective in Zero Ex To GridPort/Zero Export To CT modes)

**PV Off:** During the specified time period, PV is turned off and does not operate (used in negative electricity price scenarios).

**Time1:** real time, range of 00:00-24:00.

**Power:** Max.discharge power of battery allowed.

**Batt(V or SOC %):** Battery SOC % or voltage at when the action is to happen.

During the current time period, If the actual SOC or voltage of the battery is lower than the target value, the battery needs to be charged by the ticked source. If the actual SOC or voltage of the battery is higher than the target value, the battery can discharge, and when the solar power is not enough to power the load or the "Selling First" is enabled, the battery will discharge to feed to grid.

### For example:

During 00:00-08:00,  
if battery SOC is lower than 90%, it will use grid to charge the battery until battery SOC reaches 90%.  
During 08:00-12:00,  
if battery SOC is higher than 40%, hybrid inverter will discharge the battery until the SOC reaches 40%. At the same time, if battery SOC is lower than 40%, then grid will charge the battery SOC to 40%.  
During 12:00-14:00,  
if battery SOC is lower than 90%, it will use grid to charge the battery until battery SOC reaches 90%.  
During 14:00-18:00,  
when battery SOC is higher than 40%, hybrid inverter will discharge the battery until the SOC reaches 40%.if battery SOC is lower than 40%, neither the diesel generator nor the grid will charge the battery.

During 18:00-21:00, when battery SOC is higher than 40%, hybrid inverter will discharge the battery until the SOC reaches 40%. At the same time, if battery SOC is lower than 40%, then diesel generator will charge the battery SOC to 40%.  
 During 21:00-00:00, if battery SOC is lower than 90%, it will use grid or diesel generator to charge the battery until battery SOC reaches 90%.

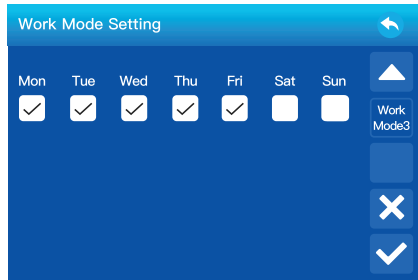

It allows users to choose which day to execute the setting of "Time Of Use". For example, the inverter will execute the time of use page on Mon/Tue/Wed/Thu/Fri only.

## 5.8 Grid Setting

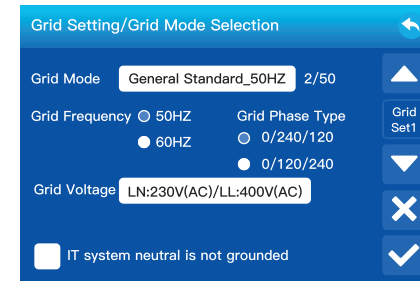

**Unlock Grid Setting:** Before changing the grid parameters, please enable this with password of 123456. Then it is allowed to change the grid parameters.

**Grid Code:**

- |                           |                           |                                |
|---------------------------|---------------------------|--------------------------------|
| 0: Germany_VDE4105,       | 7: NewZealand_AS4777,     | 13: Czech_CSN 50549-1,         |
| 2: General Standard_50Hz, | 8: SouthAfrican_NRS097,   | 14: Austria_R25:2020-03,       |
| 3: General Standard_60Hz, | 9: Netherland_EN 50549-1, | 15: Austria_OVE-directive_R25, |
| 4: Italy_CEI_021_2019,    | 10: Brazil,               | 16: Spain_NTS_2021,            |
| 5: Britain_G99,           | 11: En50549,              | 17: Spain_UNE217001,           |
| 6: Australia_A,           | 12: Poland_NC_RFG,        | 18: cNetherland.               |

**Grid Type:** The output type of the inverter in off-grid mode.

**Grid Voltage:** Select the output voltage type;

**IT system neutral is not grounded:** Reserved

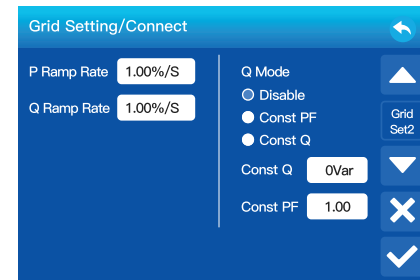

**P Ramp Rate:** It is the power ramp response to the active power reference in normal running.

**Q Ramp Rate:** It is the power ramp response to the Reactive power reference in normal running.

**Const Q:** Setting the reactive power value. Const Q >0 means Inverter output capacitive reactive power, Const Q <0 means Inverter output Inductive reactive power.

**Const PF:** Setting the power factor(cos φ) value. Const PF >0 means Inverter output Inductive reactive power(or inverter will absorb capacitive reactive power from the power grid), Const PF <0 means Inverter output capacitive reactive power.

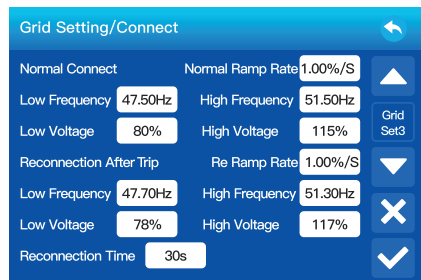

**Normal Connect:** The allowed grid voltage/frequency range when the inverter operates normally.  
**Normal Ramp Rate:** It is the startup power ramp.  
**Low Frequency:** If the grid frequency is lower than the set point, the inverter disconnects the grid.  
**High Frequency:** If the grid frequency is higher than the set point, the inverter disconnects the grid.  
**Low Voltage:** If the grid voltage is lower than the set point, the inverter will disconnect the grid.  
**High Voltage:** If the grid voltage is higher than the set point, the inverter will disconnect the grid.  
**Reconnect After Trip:** The allowed grid voltage/frequency range for the inverter connects the grid after the inverter trip from the grid.  
**Re Ramp Rate:** It is the reconnection power ramp.  
**Reconnection Time:** The waiting time for the inverter connects the grid again after tripping.

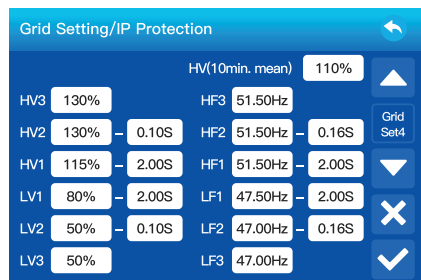

**HV1:** Level 1 overvoltage protection point;  
**HV2:** Level 2 overvoltage protection point;  
**HV3:** Level 3 overvoltage protection point.  
**LV1:** Level 1 undervoltage protection point;  
**LV2:** Level 2 undervoltage protection point;  
**LV3:** Level 3 undervoltage protection point.  
**HF1:** Level 1 over frequency protection point;  
**HF2:** Level 2 over frequency protection point;  
**HF3:** Level 3 over frequency protection point.  
**LF1:** Level 1 under frequency protection point;  
**LF2:** Level 2 under frequency protection point;  
**LF3:** Level 3 under frequency protection point.

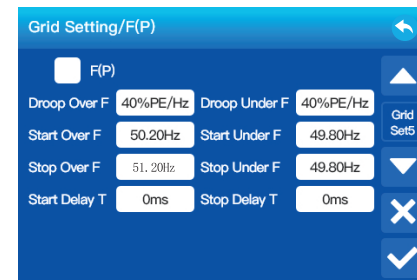

**F(P):** It's used to adjust the output active power of inverter according to grid frequency.  
**Droop Over F:** percentage of nominal power per Hz  
 For example, "Start freq F=50.2Hz, Stop freq F=51.2Hz. Droop F=40%PE/Hz" when the grid frequency reaches 51.2Hz, the inverter will decrease its active power at Droop F of 40%. And then when grid system frequency is less than 50.2Hz, the inverter will stop decreasing output power. For the detailed setup values, please follow the local grid code.  
**Start Over F:** Indicates the start of mains overfrequency derating.  
**Stop Over F:** Indicates the end point of the mains over frequency derating.  
**Start Delay T:** delay time of mains frequency response.  
**Droop Under F:** Percentage of under frequency power rise per Hz.  
**Start Under F:** Indicates the start of the mains under frequency rise.  
**Stop Under F:** Indicates the end point of the mains under frequency rise.  
**Stop Delay T:** Delay time for stopping mains frequency response.

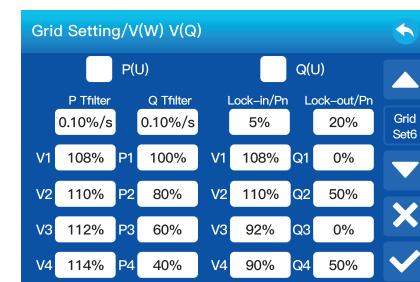

**P(U):** It is used to adjust the inverter's active power according to the set grid voltage  
**Q(U):** It is used to adjust the inverter's reactive power according to the set grid voltage. These two functions are used to adjust inverter's output power (active power and reactive power) when grid voltage changes.  
**Lock-in/Pn 5%:** When the inverter active power is less than 5% rated power, the V(Q) mode will not take effect.  
**Lock-out/Pn 20%:** If the inverter active power is increasing from 5% to 20% rated power, the V(Q) mode will take effect again.  
**For example:** V2=110%, P2=80%. When the grid voltage reaches 110% of the rated grid voltage, inverter will reduce its active power output to 80% of the rated power.  
**For example:** V1=108%, Q1=0%. When the grid voltage reaches 108% of the rated grid voltage inverter will output reactive power that accounts for 0% of the rated power. For the detailed setup values, please follow the local grid code.

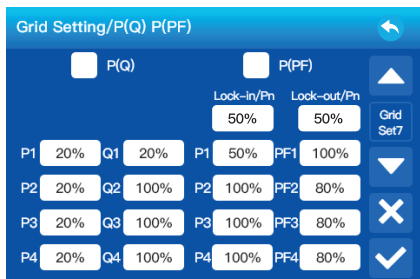

**P(Q):** it is used to adjust the output reactive power of inverter according to the set active power.  
**P(PF):** It is used to adjust the PF of inverter according to the set active power. For the detailed setup values, please follow the loca!grid code.  
**Lock-in/Pn 50%:** When the output active power of inverter is less than 50% of inverter's rated power, it won't enter the P(PF) mode.  
**Lock-out/Pn 50%:** When the output active power of inverter is higher than 50% of inverter's rated power, it will enter the P(PF) mode.

**Note :** only when the grid voltage is equal to or higher than 1.05 times of the rated grid voltage, then the P(PF) mode will take effect.

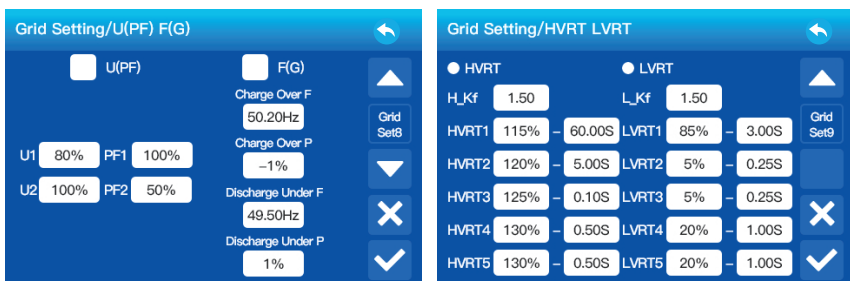

**Reserved:** This function is reserved. It is not recommended.

## 5.9 Gen Port Setting

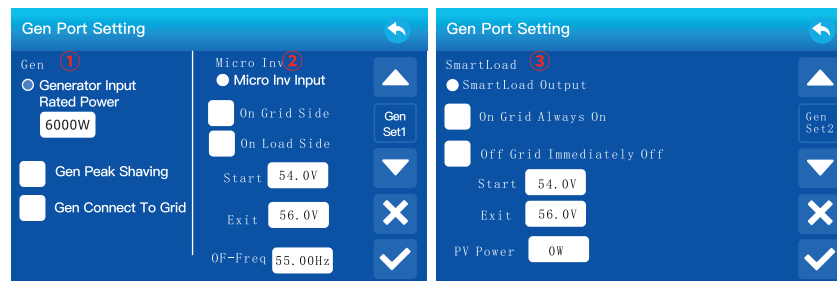

①

**Generator Input Rated Power:** allowed Max. power from diesel generator.  
**Gen Peak Shaving:** Limit the maximum output power of the generator to the set rated power, the rest of power consumption will be provided by inverter to ensure that the generator will not overload.  
**Gen Connect To Grid:** connect the diesel generator to the grid input port.

②

**Micro Inv Input:** Use the GEN port as an AC couple input port which can be connected with micro-inverter or other Grid-Tied inverter.  
**On Grid Side:** Reserved  
**On Load Side:** Use the Load port as an AC couple input port, which can be connected with micro-inverter or other Grid-Tied inverter.  
**Start:** Micro-reverse start, battery voltage point (battery SOC point)  
**Exit:** Micro-reverse exit, battery voltage point (battery SOC point)  
**OF-Freq:** If choosing "Micro Inv Input", as the battery SOC reaches gradually setting value (OFF), During the process, the microinverter output power will decrease linear. When the battery SOC equals to the setting value (OFF) the system frequency will become the setting value (AC Couple Fre H) and the Microinverter will stop working. Stop exporting power produced by the microinverter to the grid.

③

**Smart Load Output:** Select smart load output mode  
**On Grid Always On:** When click "on Grid always on" the smart load will switch on when the grid is present.  
**Off Grid immediate Off:** When this option is checked, the smart load will disconnect immediately if the system switches to off-grid mode.  
**Start:** Smart load starts, battery voltage point (battery SOC point)  
**Exit:** Smart load exits, battery voltage point (battery SOC point)  
**PV Power:** Smart load starts, PV power point.

Generator Setting/IP Protection						
Volt	Value	Time	Freq	Value	Time	
HV1	115%	2.00S	HF1	50.50Hz	2.00S	Gen Set2
HV2	130%	0.10S	HF2	51.00Hz	0.16S	
LV1	80%	2.00S	LF1	47.50Hz	2.00S	
LV2	50%	0.10S	LF2	47.00Hz	0.16S	

**HV1:** Level 1 overvoltage protection point and protection time;  
**HV2:** Level 2 overvoltage protection point and protection time;  
**LV1:** Level 1 undervoltage protection point and protection time;  
**LV2:** Level 2 undervoltage protection point and protection time;  
**HF1:** Level 1 over frequency protection point and protection time;  
**HF2:** Level 2 over frequency protection point and protection time;  
**LF1:** Level 1 under frequency protection point and protection time;  
**LF2:** Level 2 under frequency protection point and protection time.

## 5.10 Profession Setting

Profession Setting	
<input type="checkbox"/> Parallel	Factory Reset
<input type="radio"/> Master	Clear History Fault
<input type="radio"/> Slave	Clear Current Fault
Zero Export Select	Grid Meter2
<input type="radio"/> CT	Force Off Grid
<input type="radio"/> EleMeter	

CAN ID: 10  
 CT Ratio: 2000:1  
 Meter Select: No Meter

**Parallel:** To expand system capacity, click the parallel. In a parallel system, there can only be one Master for one phase, and the others must be set as Slaver, set a unique CAN ID to each inverter, and the CAN ID is from 1 to 10.

**Master:** Select any hybrid inverter in the parallel system as the master inverter, and the master inverter needs to manage the working mode of the parallel system.

**Slave:** Set the other inverters managed by the master inverter as slave inverter.

**CAN ID:** The Modbus address of each inverter should be different.

### Zero Export Select:

To CT mode can be used to select anti-reverse current mode for inverter, either CT or electric meter.

**CT:** Select CT .

**CT Ratio:** The CT ratio of the zero-export to CT mode.

The inverter is standardly equipped with a 2000:1 CT.

When using zero-export to CT mode, the hybrid inverter can select EX Meter or CT and use the different meters, e.g. Acrel and CHINT.

**EleMeter:** Select Meter.

**Meter Select:** Select the corresponding meter type according to the meter installed in the system.

**Factory Reset:** If selected, enter the password first (Password: 666666); Deselect it, you do not need to enter a password.

**Clear History Fault:** Clear the fault history.

**Clear Current Fault:** Clear the current fault and restart the inverter.

**Grid Meter2:** When there's a string inverter AC couple at the grid or load side of hybrid inverter and there's a meter installed for the string inverter, then the hybrid inverter LCD will show the string inverter output power on its PV icon. Please make sure the meter can communicate with the hybrid inverter successfully.

**Force Off Grid:** Forces grid disconnection; takes effect in non-TOU mode.

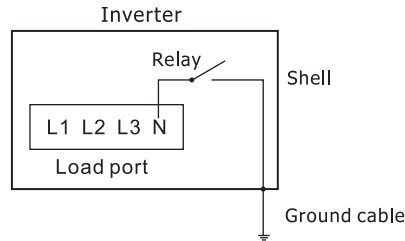
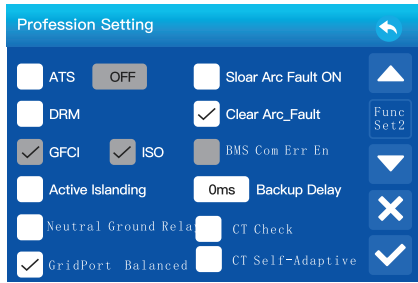

- ATS:** It is related with ATS port voltage. it is better in "uncheck" position.
- DRM:** Only for AS4777 standard.
- GFCI:** the ground-fault circuit interrupter function.
- ISO:** the PV and the battery wiring terminals Positive to ground and negative to ground insulation impedance detection.
- Active Islanding:** Active islanding detection enable or not.
- Neutral Ground Relay:** Neutral ground relay closure enable;
- GridPort\_Balanced:** When enabled, the grid port can output balanced power; ;
- Sloar Arc Fault ON:** This is only for US.
- Clear Arc Fault:** Clear Arc\_Fault.
- BMS Com Err En:** When it is active, if the battery BMS failed to communicate with inverter, the inverter will stop working and report fault.
- Backup Delay:** When the grid cuts off, the inverter will output power after the set time. For example, backup delay: 15ms, the inverter will give output power after 15ms when the grid cuts off.
- CT Check:** CT One-Click Self-Check;
- CT Self-Adaptive:** CT one-click adaptive self-test; when checked, the CT can automatically adjust the phase sequence and orientation.

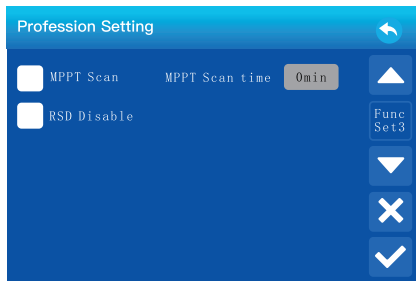

- MPPT Scan:** MPPT global scan function;
- MPPT Scan time:** Global scan interval
- RSD Disable:** Fast shutdown function; upon receiving this signal after enabling, the inverter quickly shuts down.

## 6. System Application

### Mode I:Basic

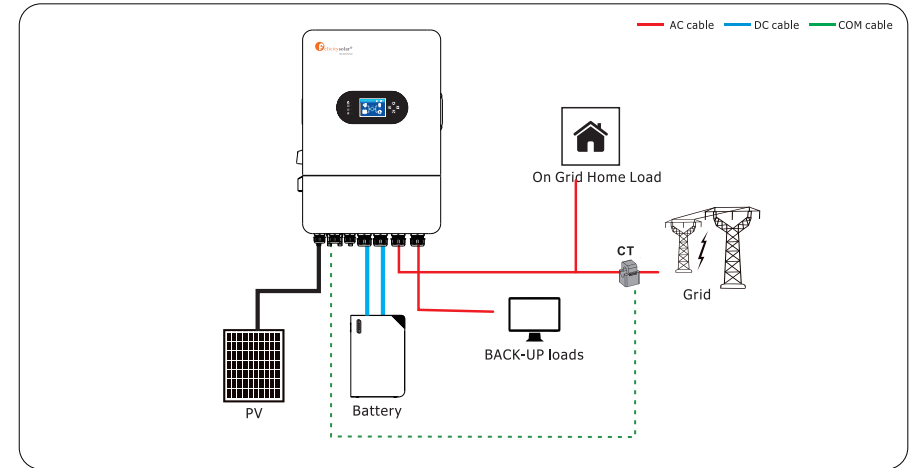

With Export to CT mode, the hybrid inverter can provide power not only to the home load on the main side, but also to the critical load on the backup side. And excess energy feeds to Grid.

### Mode II:With Generator

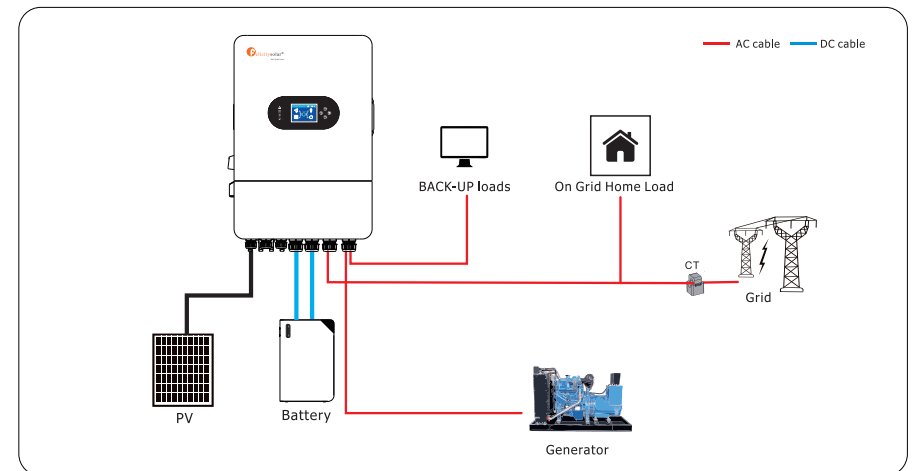

#### Generators Smaller than 12kW(On "GEN" Input)

1. ONLY supports three-phase 400Vac generators.
2. 55A rated "GEN" terminal. 31.9A continuous.
3. A THD (Total Harmonic Distortion) of less than 15% is required for stable operation.

#### Generators Greater than 12kW(On "GRID" Input)

1. ONLY supports three-phase 400Vac generators.
2. Optimal way to integrate generators for Off-Grid or Grid-Tied systems with automatic or manual transfer switches.

3. Programming "GEN Connect to Grid Input" and generator connected to grid port.
4. DO NOT use "Sell to Grid" when generator is connected to the GRID input, can cause potential damage the generator. Installation of CT sensors on generator lines is only required if "Peak Shaving" is intended to be used.

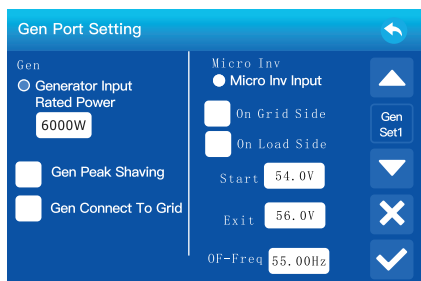

### Mode III: With Smart-Load

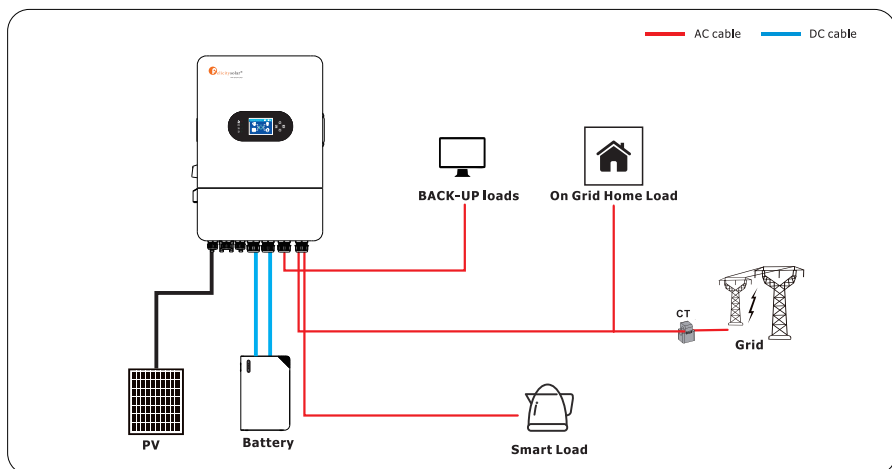

1. This mode uses the "Generator" input as a load output that delivers power when the battery exceeds a user programmable threshold or when the IVGM INVERTER is connected to the grid.
2. When "Smart Load Output" is enabled, the "GEN" input turns into an output to power high power loads such as a water heater, irrigation pump, AC unit, pool pump, or any other load.
3. When "On Grid Always On" is enabled, the "GEN" terminal will always output power as long as the grid is connected, regardless of battery charge.

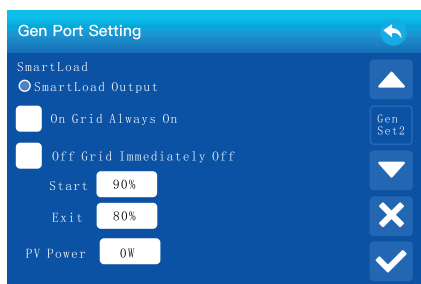

### Mode IV: AC Couple

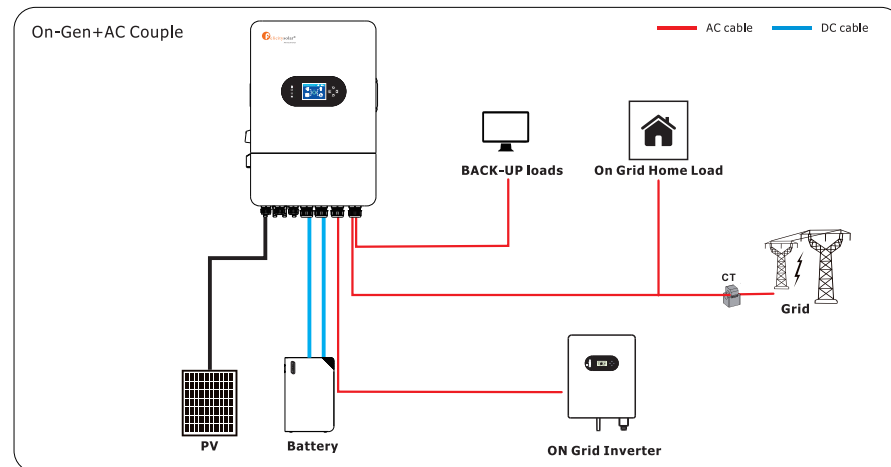

The IVGM INVERTER supports the addition of grid-tied solar inverters, this allows the systems total solar power input to be expanded by coupling micro or string inverters into the "GEN" terminals of the inverter.

An entirely AC-coupled solar system is not recommended as power control and monitoring is limited but is supported. Having DC-coupled modules, or a combination of DC-coupled modules and AC-coupled inverters is always preferred. AC-coupled inverters used in this application need to be either EN 50549 or VDE 4105 certified. This certification confirms the inverters' ability to disconnect from the grid based on frequency and ensures that the IVGM INVERTER will safely be able to frequency shift to control the AC coupled production.

In off-grid systems or during grid-forming operation, the IVGM INVERTER uses frequency shifting to curtail and shutdown AC-coupled inverters when the battery is full, allowing AC-coupled solar to produce power in an outage scenario. When the IVGM INVERTER is connected to the grid any AC-coupled inverters connected will always sell all excess solar power back to the grid. Selecting "Limited to Load" will NOT limit production when AC coupled.

### AC Coupling on the GRID Side

Installing AC coupled inverters upstream of the GRID port of the IVGM INVERTER, such as with a load or supply side connection, is supported for grid connected systems but has some notable limitations when using the inverter for backup or grid-forming mode:

- Does NOT allow the usage of grid-tied inverter production during grid outages to charge batteries or power loads.
- Does NOT allow monitoring of PV production in inverter and Fsolarr monitoring.

### AC Coupling on the GEN Terminal

AC Coupling via the GEN Terminal is the preferred method for integrating AC-coupled solar on the IVGM INVERTER. This method offers several key advantages:

- Allows the usage of grid-tied inverter production during grid outages.
- Allows the integration of grid-tie inverters in off-grid systems.

Using the GEN terminal also allows for comprehensive monitoring of solar production, giving users valuable insights into the system's performance.

## 7. Warranty

As to Warranty terms, please refer to <General Warranty Agreement>.

Under the guidance of our company, customers return our products so that our company can provide service of maintenance or replacement of products of the same value. Customers need to pay the necessary freight and other related costs. Any replacement or repair of the product will cover the remaining warranty period of the product. If any part of the product or product is replaced by the company itself during the warranty period, all rights and interests of there placement product or component belong to the company.

Factory warranty does not include damage due to the following reasons:

- Damage during transportation of equipment;
- Damage caused by incorrect installation or commissioning;
- Damage caused by failure to comply with operation instructions, installation instructions or maintenance instructions;
- Damage caused by attempts to modify, alter or repair products;
- Damage caused by incorrect use or operation;
- Damage caused by insufficient ventilation of equipment;
- Damage caused by failure to comply with applicable safety standards or regulations;
- Damage caused by natural disasters or force majeure (e.g. floods, lightning, over voltage, storms, fires, etc.)

In addition, normal wear or any other failure will not affect the basic operation of the product. Any external scratches, stains or natural mechanical wear does not represent a defect in the product.

## 8. Troubleshooting

Perform troubleshooting according to the solutions in the table below. Contact the after-sales service if these methods do not work.

Collect the information below before contacting the after-sales service, so that the problem scan be solved quickly.

- Inverter information like serial number, firmware version, installation date, fault time, fault frequency, etc.
- Installation environment, including weather conditions, whether the PV modules are sheltered or shadowed, etc. It is recommended to provide some photos and videos to assist in analyzing the problem.
- Utility grid situation.

## 9. APP Download the APP

**Method 1:** Access <https://download.felicitysolar.com> using the mobile phone browser and download the latest installation package.

**Method 2:** Scan the following QR code and download the latest installation package.



Please refer the Fsolar End user manual, register the installer and create a plant and owner (skip this step if the account has been created). You can obtain the Fsolar End user manual by scanning the following QR code.



## 10. Warning Code

When fault event happens, the fault LED is flashing. At the same time, warning code, icon  is shown on the LCD screen.

Warning Code	Warning Information	Trouble shooting
2	Battery Under Voltage Alarm	Battery voltage is too low, the battery should be charged
3	Battery SOC Low Alarm	Battery voltage is too low or Battery SOC is too low, the battery should be charged
15	Heat Sink Overtemperature Derating Alarm	Reduce the ambient temperature of the device
16	Internal Environment Overtemperature Derating Alarm	Reduce the ambient temperature of the device
17	AFCI Communication Alarm	The AFCI communication is abnormal, check AFCI wiring
18	External Fan Alarm	External fan malfunction, check fan for proper functioning
19	GridCOROFAlarm	ROCOF alarm
22	Internal Fan Alarm	Internal malfunction, check fan for proper functioning
23	Meter Communication Alarm	The Meter communication is abnormal, check Meter wiring
24	External CT Sensor Reverse	Check the connection of CT is correctly

26	Software and Hardware Versions Do Not Match	The inverter will halve the power, Seek help from us.
27	MicInvMeterComAbNormal	Micro-inverter meter communication anomaly alarm
28	GridOVAlarm	Grid overvoltage alarm
29	GridUVAlarm	Grid undervoltage alarm
30	GridOFAlarm	Grid Over-frequency alarm
31	GridUFAlarm	Grid under-frequency alarm
32	GridIslandAlarm	Active island alert

## 11. Fault Code

This chapter describes the fault alarm and fault code for quick troubleshooting.

Warning Code	Warning Information	Trouble shooting
01	PV Overvoltage Fault	The voltage of the PV is too high, check the voltage of the string
05	PV Overcurrent Fault	The current of the PV is too large, check the string current
09	PV Reverse Connection Fault	PV string positive and negative connection, check the string wiring
13	PV Arc Fault	Reserved
17	Battery Overvoltage Fault	Battery voltage is too high, the battery should be discharged
19	Battery Undervoltage Fault	Battery voltage is too low, the battery should be charged
20	Battery Over Current Fault	Battery current is too high, shutdown and restart
26	Battery SOC Low Fault	Battery SOC is too low, the battery should be charged
38	Bus Overvoltage Fault	Bus voltage is too high, shutdown and restart
40	Bus Undervoltage Fault	Bus voltage is too low, shutdown and restart
41	Positive and Negative Bus Imbalance Fault	Positive bus voltage does not match negative bus voltage, shutdown and restart
42	Bus Soft Start Fault	Bus voltage fails to rise normally at startup, shutdown and restart
44	Balanced Bridge Overcurrent Fault	Balanced bridge current is too high, shutdown and restart

## Hybrid inverter

<b>46</b>	HardwareVersionFault	Hardware version error
<b>47</b>	LLCHardOC	LLC hardware overcurrent fault
<b>49</b>	Inverter Self Check Fault	Reserved
<b>50</b>	Inverter Soft Start Fault	Inverter voltage fails to rise normally at startup,shutdown and restart
<b>51</b>	Inverter Voltage Fault	Inverter voltage is too high,shutdown and restart
<b>52</b>	Inverter Overcurrent Fault	Inverter current is too high,check the given power and load size
<b>54</b>	Inverter Short Circuit Fault	Short circuit at inverter,shutdown and restart
<b>55</b>	Inverter Voltage DC Component Fault	Inverter voltage DC component is too high,shutdown and restart
<b>56</b>	Inverter Current DC Component Fault	Inverter current DC component is too high,shutdown and restart
<b>57</b>	Grid Overvoltage Fault	The grid voltage is too high,check whether the grid voltage is within the normal range
<b>58</b>	Grid Undervoltage Fault	The grid voltage is too low,check whether the grid voltage is within the normal range
<b>59</b>	Grid Over-frequency Fault	The grid frequency is too high,check whether the grid frequency is within the normal range
<b>60</b>	Grid Underfrequency Fault	The grid frequency is too low,check whether the grid frequency is within the normal range
<b>61</b>	Grid Reverse Sequence Fault	The grid phase sequence is reversed,check the grid phase sequence wiring
<b>62</b>	Grid Overload Fault	The load of the grid access is too large,and the load should be reduced

## Hybrid inverter

<b>65</b>	Load Overload Fault	The load exceeds ,the load should be reduced
<b>70</b>	IGBT Over-temperature Fault	Inverter device temperature is too high
<b>71</b>	Ambient Overtemperature	The ambient temperature of the inverter is too high
<b>72</b>	Fan Fault	Fan is faulty,check whether the fan is normal
<b>77</b>	EEPROM Fault	There was an error with the EEPROM write
<b>78</b>	12V Auxiliary Power Supply Fault	Failure of 12V auxiliary power supply
<b>79</b>	CT or Hall Open Circuit Fault	current sensing device is faulty,check CT or Hall element connections
<b>80</b>	Main and Auxiliary DSP CommunicationFault	There is an error in the DSP communication,try to upgrade the software
<b>81</b>	MCU Communication Fault	There is an error in the MCU communication, try to upgrade the software
<b>83</b>	Leakage Current Fault	The leakage current of the inverter is too large,check the wiring of the inverter
<b>84</b>	BUS Insulation Impedance Fault	The insulation of the BUS string is abnormal
<b>88</b>	GEN Relay Fault	Gen relay not closing properly causing open circuit,or Gen relay not properly disconnected causing short circuit,shutdown and restart
<b>89</b>	Grid Relay Fault	Grid relay not closing properly causing open circuit,or Grid relay not properly disconnected causing short circuit,shutdown and restart
<b>90</b>	Inv Relay Fault	Inv relay not closing properly causing open circuit,or Inv relay not properly disconnected causing short circuit,shutdown and restart
<b>93</b>	PWM SYNC Fault	The inverter is connected to abnormal parallel communication

94	Parallel CAN Communication	The inverter is connected to abnormal parallel communication
95	Parallel Host loss Fault	Parallel host disconnects from the system,check whether the hosts is normal
96	Zero SYNC Fault	The inverter is connected to abnormal parallel communication
97	Master Clash Fault	There is more than two Parallel host , check whether the hosts is normal
98	GEN Overvoltage Fault	The generator voltage is too high,check whether the generatord voltage is within the normal range
99	Grid Undervoltage Fault	The generator voltage is too low,check whether the generator voltage is within the normal range
100	Grid Over-frequency Fault	The generator frequency is too high,check whether the generator frequency is within the normal range
101	Grid Underfrequency Fault	The generator frequency is too low,check whether the generator frequency is within the normal range
102	Grid Reverse Sequence Fault	The generator phase sequence is reversed,check the generator phase sequence wiring
103	GEN Overload Fault	The generator exceeds ,the generator should be reduced
104	BMS Com Circuit Fault	BMS fails to communicate normally,check the BMS communication cable
106	Remote Off	Remotely shutdown It means the inverter is remotely controlled
107	Mode Change	1 When the grid type and frequency have changed it will eport F65. 2. When the battery mode has been changed to "No battery" mode,it will report F65.
108	Flash Data Missing	Remotely shutdown It means the inverter is remotely controlled

## 12 Appendix

Model	IVGM 12KLP3G2	IVGM 10KLP3G2	IVGM 8KLP3G2	IVGM 6KLP3G2	IVGM 5KLP3G2	IVGM 4KLP3G2	IVGM 3KLP3G2
<b>Battery Input Data</b>							
Battery type	Li-Ion/Lead-acid						
Battery Voltage Range	40~60V						
Max.charging current	240 A	210 A	190 A	135 A	120 A	95 A	70 A
Max. discharging current	240 A	210 A	190 A	135 A	120 A	95 A	70 A
Charging Curve	3 Stages/Equalization						
Charging Strategy for Li-Ion Battery	Self-adaption to BMS						
<b>PV String Input Data</b>							
Max. PV Input Power	18 kW	15 kW	12 kW	9 kW	7.5 kW	6 kW	4.5 kW
Max. PV Input Voltage	800V						
Start-up Voltage	160V						
MPPT Voltage Rang	200~650V						
Rated DC Input Voltage	550V						
Full Load MPPT Voltage Range	350~650V		250~650V				
Max. Operating PV Input Current	26+26(A)	26+26(A)	20+20(A)	20+20(A)	20+20(A)	20+20(A)	20+20(A)
Max. Input Short-Circuit Current	39+39(A)	39+39(A)	30+30(A)	30+30(A)	30+30(A)	30+30(A)	30+30(A)
No. of MPP Trackers /No. of Strings MPP Tracker	2/2+2						
Max. Inverter Backfeed Current to The Array	0						
<b>AC Input/Output Data</b>							
Rated AC Input/Output Active Power	12 kW	10 kW	8 kW	6 kW	5 kW	4 kW	3 kW
Max. AC Input/Output Apparent Power	13.2 kVA	11 kVA	8.8 kVA	6.6 kVA	5.5 kVA	4.4 kVA	3.3kVA
Peak Power (off-grid)	2 times of rated power, 10s						
Rated AC Input/Output Current	17.4 A	14.5A	11.6 A	8.7 A	7.3 A	5.8 A	4.4 A
Max.AC Input/Output Current	19.2 A	16.0 A	12.6 A	9.7 A	9.0 A	6.4A	4.8 A
Max. Continuous AC Passthrough (grid to load)	45A			45A			
Max. Output Overcurrent Protection	52A			52A			
Rated Input/Output Voltage/Range	220/380,230/400Vac (-20%~+15%)						
AC Wiring Mode	3L+N+PE						
Rated Input/Output Grid Frequency/Range	50 /60 Hz (45~55Hz/55~65Hz)						
Power Factor Adjustment Range	0.8( leading) to 0.8( lagging)						
Total Current Harmonic Distortion THDi	<3%( of nominal power)						
DC Injection Current	<0.5% In						

Efficiency	
Max. efficiency	97.6%
Euro efficiency	97%
MPPT efficiency	>99%
Equipment Protection	
DC Polarity Reverse Connection Protection	YES
AC Output Overcurrent Protection	YES
AC Output Overvoltage Protection	YES
AC Output Short Circuit Protection	YES
Thermal Protection	YES
DC Terminal Insulation Impedance Monitoring	YES
DC Component Monitoring	YES
Ground Fault Current Monitoring	YES
Arc fault circuit interrupter (AFCI)	YES
power Network Monitoring	YES
Island Protection Monitoring	YES
Earth Fault Detection	YES
DC input Switch	YES
Overvoltage Load Drop Protection	YES
Residual Current (RCD) Detection	YES
Surge Protection Level	TYPE II(DC), TYPE II(AC)
Certification and Standards	
Grid Regulation	NRS 097-2-1,VDE4105,EN50549-1,AS 4777.2, GB/T 34120,GB/T 34133,GB/T 34129
Safety EMC / Standard	IEC/EN 61000-6-1/2/3/4,IEC/EN 62109-1,IEC/EN 62109-2
General Data	
Net Weight	37.1kg
Gross Weight	46.6kg
Product Dimension	634x444.5x255.2mm
Package Dimension	775x530x404mm
Protection Degree	IP65
Operating Temperature Range	-40 to 60 °C (>45 °C derating)
Humidity	0 ~ 95 % (No condensation)
Cooling	Smart cooling
Communication with BMS	RS485, CAN
Monitor module	WiFi/4G
Installation Style	Wall-mounted
Warranty	5 Years the Warranty Period Depends the Final Installation Site of Inverter More Info Please Refer to Warranty Policy