

Quick Installation Guide

LiFePO4 Battery System for Households

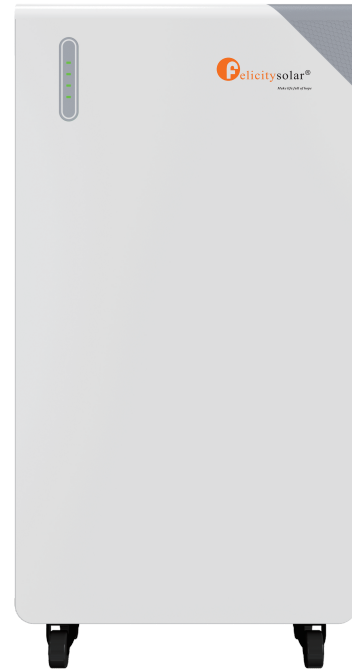









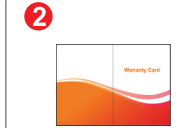

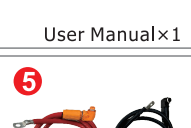
358-030059-00

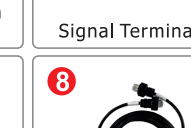
Disclaimer





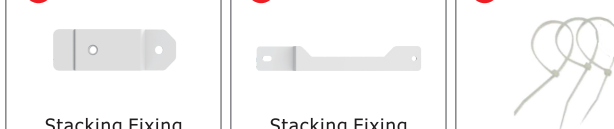







- Please read the user's manual carefully before performing all operations; this installation guide does not supersede the use of the product's user's manual;
- Product information is subject to change without notice. This manual is frequently updated, please contact your salesperson for the latest version.
- After unpacking, please check the product for damages and missing parts.
- Do not open the battery to repair or disassemble. Only FelicitySolar is allowed to carry out any such repairs. Only qualified personnel can install this device with battery.
- In case of fire, use only dry powder fire extinguisher. Liquid extinguishers should not be used.
- Before using the battery, please read the instructions and warning signs of the battery and corresponding sections in the instruction manual. Improper reassembly may result in electric shock or fire.
- To reduce risk of electric shock, disconnect all wires before attempting any maintenance or cleaning. Turning off the unit will not reduce this risk.
- Never charge a frozen battery.
- Be very cautious when working with metal tools on or around batteries. Dropping a tool may cause a spark or short circuit in batteries or other electrical parts, even cause an explosion.
- Install the battery away from children or pets.
- Do not use battery in high static environment where the protection device might be damaged.
- Battery should be installed indoor and kept away from water, high temperature mechanical force and flames.
- Do not install the battery in any environment of temperature below -20°C or over 55°C, and humidity over 95%.



Packing List

 User Manual×1	 Warranty Card ×1	 Quick Installation Guide×1	 Signal Terminal×2
 Power Cable×2	 Communication Cable×1	 Communication Cable×1	 Communication Cable×1
 Lock Wall Components×2	 Stacking Fixing Bracket A×2	 Stacking Fixing Bracket B×2	 Ribbon×3
 Fuse×1	 Expansion tube 8X40*2 PCS Screws M5X25*2 PCS Screws M5X12*4 PCS Screws M6X14*4 PCS		

FLB48280TG1-AU/FLB48279TG1-AU			
NO.	Name	Description	Quantity
1	User Manual	User manual	1
2	Warranty Card	Warranty card	1
3	Quick Installation Guide	Quick Installation Guide	1
4	Signal Terminal	Used for creating custom communication cables	2
5	Power Cable	50mm ² , used for connecting to external PCS	2
6	Communication Cable	Gray, used for RS485 communication with Felicity inverters (Model:IVCM,IVEM,IVPS/M IVGM)	1
7	Communication Cable	Blue, Used for communication with inverters from other brands.	1
8	Communication Cable	Black,used for parallel communication between battery packs	1
9	Lock Wall Components	Used for product wall fixation	2
10	Stacking Fixing Bracket A	Used for battery fixation and positioning	2
11	Stacking Fixing Bracket B	Used for fixing two batteries	2
12	Ribbon	Used to fix the power cable	3
13	Fuse	Spare parts for repair and replacement in case of fuse damage	1
14	Screws	Expansion tube 8X40*2 PCS Screws M5X25*2 PCS Screws M5X12*4 PCS Screws M6X14*4 PCS	/

Explanation of the Symbols

	Danger! Serious physical injury or even death may occur if not follow the relative requirements.		Install the product out of reach of children
	Caution, risk of electric shock.		Do not place or install near flammable or explosive materials
	In case of electrolyte leakage, keep leaked electrolyte away from eyes or skin.		Disconnect the equipment before carrying out maintenance or repair
	Do not connect the Pack's positive(+) and negative(-) terminal reversely.		EU WEEE mark: Product should not be disposed as household waste.
	Observe precautions for handling electrostatic discharge sensitive devices.		Instruction manual: Read the instruction manual before starting installation and operation.
	Caution, risk of electric shock, energy storage timed discharge.		CE mark: The inverter complies with the CE directive.
	Recyclable.	NOTE	Note: The procedures taken for ensuring proper operation.

	Do not use the Pack beyond specified conditions.		Earth terminal: The inverter must be reliably grounded.
	Take care! This Pack is heavy enough to cause serious injury.		

Product Overview

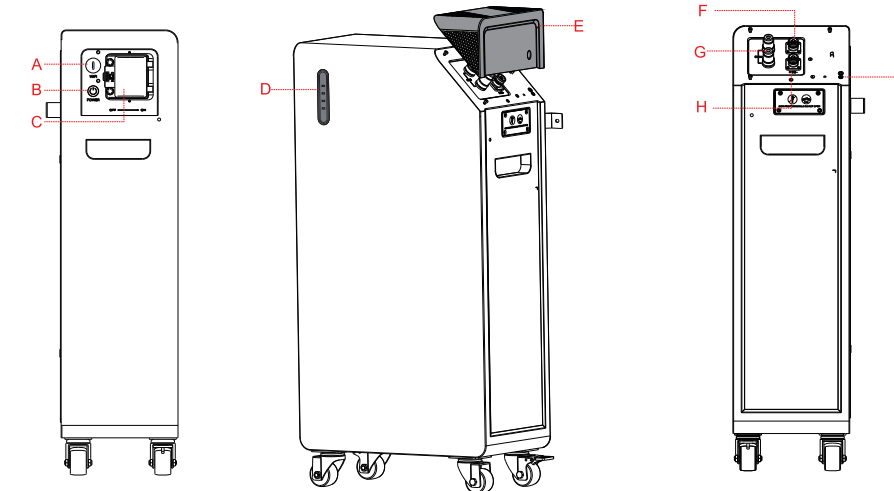

Code	Name
A	WIFI
B	Power On/Charging Indicator
C	ON/OFF Switch
D	LED
E	Decorative Cover
F	POS+
G	COM
H	NEG-
I	Earth Wire

* Fuse(Non professionals are not allowed to open this cover)



If the fuse is burnt out, please open the cover and replace it

Installation Environment

LCD Display Icons

The LED shows the SOC of module N.

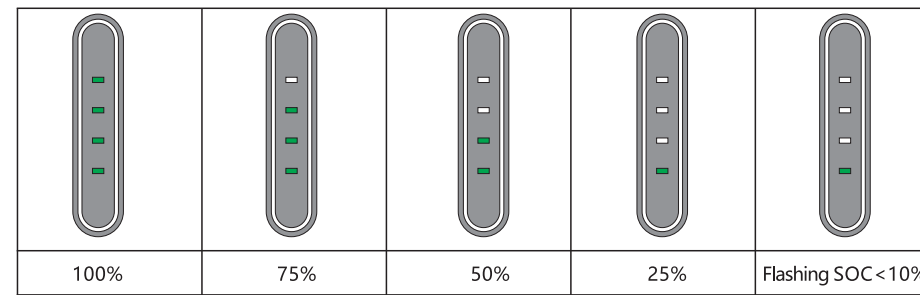

Note: The battery need to be fully charged for at least once in one month to ensure the accurate SOC calculation.

Installation Procedure

- 01: Unpack the battery system from the box. Box label: LITHIUM BATTERY SYSTEM UN3480 LITHIUM ION BATTERIES.
- 02: Mount the battery system to the chassis using M5 screws. Torque: 1.5~2N.m.
- 03: Drill a hole in the wall with a diameter of 8mm and a depth of 45mm.
- 04: Mount the battery system to the wall using M5 screws. Torque: 1.5~2N.m.

Front and Rear Floor Mounting Method:

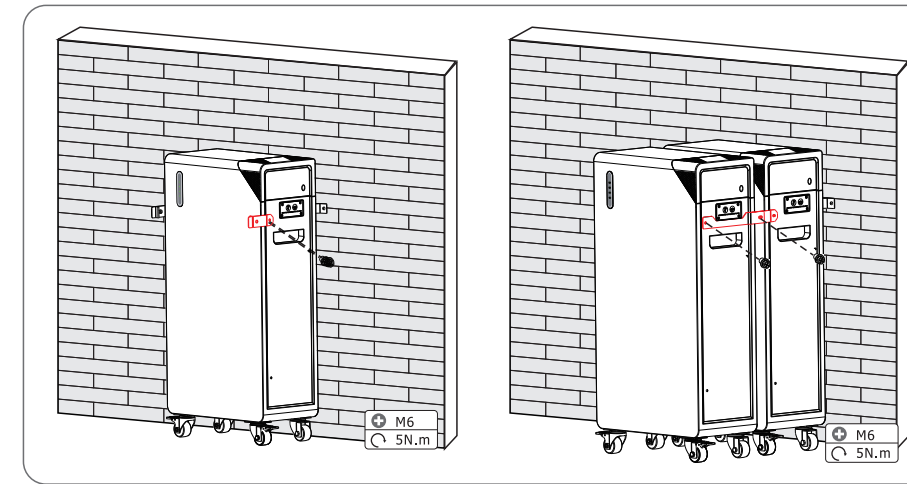

Wiring Procedure

1. Remove Decorative Cover
2. Ground Connection
3. Parallel Connection
4. Electrical Connection
5. Electrical Connection
6. Install Decorative Cover

Connection For Parallel Mode

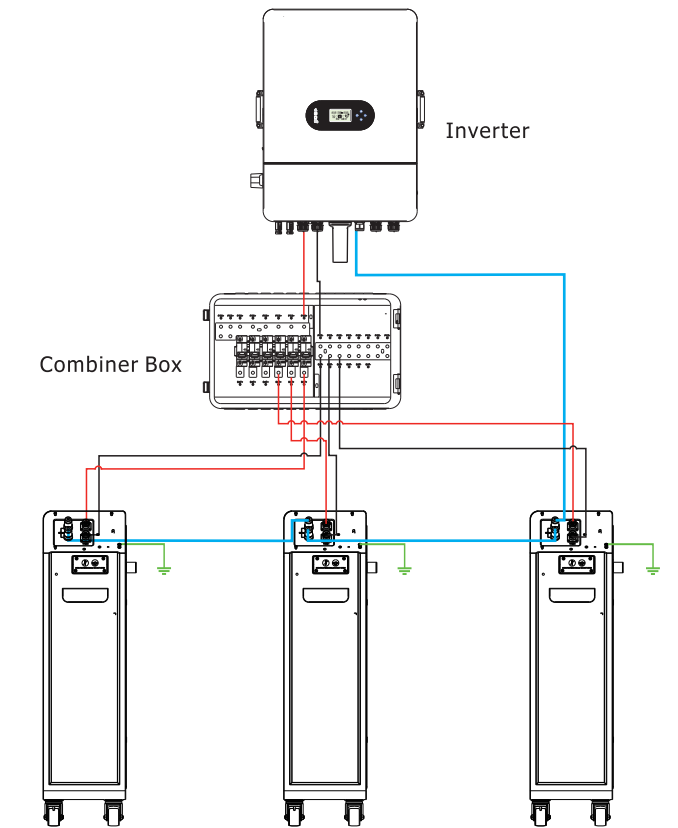

Installation Of Wifi Module

For detailed instructions on how to install WIFI Module, you can scan the QR code to the right to view the WIFI Module installation instructions.

