

LiFePO4 Battery System for Households

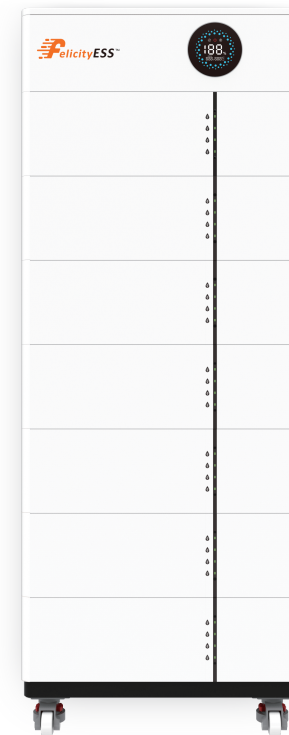

# USER GUIDE

LiFePO4 Battery System for Households



In order to prevent improper operation before use, please carefully read this manual.

# Contents

<b>1 ABOUT THIS MANUAL</b> .....	1
1.1 Purpose .....	1
1.2 Scope .....	1
1.3 Safety Instructions .....	1
1.4 Can be Connected in Parallel .....	1
1.5 Safety Rules.....	2
1.6 Safety information.....	2
1.7 Installation.....	2
<b>2 SYMBOLS</b> .....	3
<b>3 TRANSPORTATION</b> .....	3
3.1 Regulations for the transport of battery modules.....	3
3.2 Permissible and Impermissible Storage Positions of a Packaged.....	4
<b>4 STORAGE</b> .....	4
<b>5 INTRODUCTION</b> .....	5
5.1 Features.....	5
5.2 Product Overview .....	5
5.3 Specifications .....	7
5.4 Recommended Settings .....	8
5.5 Model Description.....	8
5.6 Lable.....	9
5.7 Scalability .....	10
<b>6. INSTALLATION</b> .....	10
6.1 Tools.....	10
6.2 Unpacking and Inspection.....	11
6.3 Mounting the Unit.....	12
6.4 Product Size Information.....	13
6.5 Floor Installation with Base .....	13
6.6 Installation Environment .....	14
<b>7. INSTALLATION PROCEDURE</b> .....	14
7.1 Setup Script.....	14
7.2 Connection for Parallel Mode .....	17
<b>8. OPERATION</b> .....	19
8.1 Switch On / Off .....	19
8.2 Description for LED .....	19
8.3 ON / OFF or SOC Led (Mode or SOC) .....	20

<b>9. LCD DISPLAY ICONS</b> .....	20
9.1 BMS Information Page .....	21
9.2 Fault Code Table .....	22
9.3 DIPswitch SW1-SW4 Description .....	23
<b>10. EMERGENCY SITUATIONS</b> .....	24
10.1 Fire .....	24
10.2 Leaking Batteries .....	24
10.3 Wet Batteries .....	24
10.4 Damaged Batteries .....	24
10.5 Warranty .....	24

# 1 ABOUT THIS MANUAL

## 1.1 Purpose

This manual describes the introduction, installation, operation and emergency situations of the battery bank. Please read this manual carefully before installations and operations. Keep this manual for future reference.

## 1.2 Scope

This manual provides safety and installation guidelines as well as information on tools and wiring.

## 1.3 Safety Instructions



**WARNING:** This chapter contains important safety and operating instructions. Read and keep this manual for future reference.

1. Before using the unit, read all instructions and cautionary markings on the unit, the batteries and all appropriate sections of this manual.
2. CAUTION --- To reduce risk of injury, damage, even burst. please use it following using manual. In case of causing personal
3. Do not disassemble the battery. Take it to a qualified service center when service or repair is required. Incorrect re-assembly may result in a risk of fire.
4. To reduce risk of electric shock, disconnect all wirings before attempting any maintenance or cleaning. Turning off the unit will not reduce this risk.
5. CAUTION – Only qualified personnel can install this device with inverter.
6. For optimum operation of this battery, please follow required spec to select appropriate cable size.
7. Be very cautious when working with metal tools on or around batteries. A potential risk exists to drop a tool to spark or short circuit batteries or other electrical parts and could cause an explosion or fire.
8. Please strictly follow installation procedure.
9. **GROUNDING INSTRUCTIONS** - This System should be connected to a permanent grounded wiring system. Be sure to comply with local requirements.
10. NEVER cause AC output and DC input short circuited. Do not connect to the mains when DC input short circuits.
11. Warning!! Only qualified service persons are able to service this device.
12. Battery should be installed indoor and kept away from water, high temperature mechanical force and flames.
13. Do not install the battery in any environment of temperature below 0°C or over 55°C, and humidity over 80%.
14. Do not put any heavy objects on the battery.

## 1.4 Can be Connected in Parallel

1. The batteries can be connected in parallel. Series connection is not allowed. Use in upright position only.
2. The batteries are not allowed to connected with PWM controller for charging.

**Special Attention: Due to the built-in protection board of the lithium battery pack is with over-discharge protection function, it is strongly recommended to stop using the load when the battery pack is over-discharged. The battery pack cannot be repeatedly activated for discharge. Or the battery may be failed to be activated by the AC or PV activation cable ( It requires a special charging activation method), so cannot be charged. Therefore, when the battery pack is low power, please charge the battery as soon as possible when main power or solar energy is available.**

## 1.5 Safety rules

To avoid property damage and personal injury, the following rules shall be followed when working on the hazardous live parts of the battery energy storage system:

- It is available for use.
- Ensure that it will not restart.
- Make sure there is no voltage.
- Grounding protection and short circuit protection.
- Cover or shield adjacent live parts.

## 1.6 Safety information

Part damage or short circuit may cause electric shock and death. A short circuit can be caused by connecting battery terminals, resulting in current flow. This type of short circuit shall be avoided under any circumstances. For this reason, follow these instructions:

- Use insulated tools and gloves.
- Do not place any tools or metal parts on the battery module or high-voltage control box.
- When operating the battery, be sure to remove watches, rings, and other metal objects.
- Do not install or operate this system in explosive or high-humidity areas.
- When working on the energy storage system, first turn off the charging controller, then the battery, and ensure that they are not turned on again.

**Improper** use of the battery energy storage system can lead to death. The use of the battery energy storage system beyond its intended use is not allowed, because it may cause great danger.

**Improper** handling of the battery energy storage system can cause life-threatening risks, serious injury or even death.



















**Warning!** improper use can cause damage to the battery cell.

- Do not expose the battery module to rain or soak it in liquid.
- Do not expose the battery module to a corrosive environment (such as ammonia and salt).
- The battery energy storage system shall be debugged no later than six months after delivery.

## 1.7 Installation

- After unpacking, please check the product for damages and missing parts.
- Make sure that the inverter and battery is completely turned off before commencing installation.
- Do not interchange the positive and negative terminals of the battery.
- Ensure that there is no short circuit of the terminals or with any external device.
- Do not exceed the battery voltage rating of the inverter.
- Do not connect the battery to any incompatible inverter.
- Do not connect different battery types together.
- Please ensure that all the batteries are grounded properly.
- Do not open the battery to repair or disassemble. Only FelicityESS is allowed to carry out any such repairs.
- In case of fire, use only dry powder fire extinguisher. Liquid extinguishers should not be used.
- Install the battery away from children or pets.
- Do not use battery in high static environment where the protection device might be damaged.
- Do not install with other batteries or cells.



## 2. SYMBOLS





	Danger! Serious physical injury or even death may occur if not follow the relative requirements.		Install the product out of reach of children
	Caution, risk of electric shock.		Do not place or install near flammable or explosive materials
	In case of electrolyte leakage, keep leaked electrolyte away from eyes or skin.		Disconnect the equipment before carrying out maintenance or repair
	Do not connect the Pack's positive(+) and negative(-)terminal reversely.		Societe Generale de Surveillance S.A.
	Observe precautions for handling electrostatic discharge sensitive devices.		Instruction manual: Read the instruction manual before starting installation and operation.
	Caution, risk of electric shock, energy storage timed discharge		CE mark: The inverter complies with the CE directive.
	Recyclable.	<b>NOTE</b>	Note: The procedures taken for ensuring proper operation.
	Do not use the Pack beyond specified conditions		Earth terminal: The inverter must be reliably grounded.
	Take care! This Pack is heavy enough to cause serious injury.		EU WEEE mark: Product should not be disposed as household waste.

## 3. TRANSPORTATION

### 3.1 Regulations for the transport of battery modules

It is necessary to comply with the relevant regulations and provisions on roads for shipping lithium-ion products in the corresponding countries.

-  •Smoking is prohibited in the vehicle during transportation or in the vicinity during loading and unloading
-  • The dangerous goods transport vehicles shall meet relevant regulations concerning road transportation and shall be equipped with two tested CO2 fire extinguishers.
-  • Improper vehicle transportation can cause injury. Improper transportation or improper transportation locks may cause the load to slip or overturn, resulting in injury.

-  • The battery energy storage system can be damaged, if not properly transported. The battery module can only be transported vertically. Note that these parts may be top-heavy. Failure to follow this instruction may result in damage to the part.
-  • If possible, do not remove the transport packaging before arrival at the installation site. Before removing the transport protector, check if the transport packaging is damaged, and check the impact indicator on the outer packaging of the battery converter. If the impact indicator is triggered, the possibility of transport damage cannot be ruled out.
-  • Improper transport of battery modules may cause injury. The single battery module weighs 46 kg. It could cause injury if it falls or slips. Use only suitable transport and lifting equipment to ensure safe transport.
-  • Wear safety shoes to avoid the danger of injury. When transporting the battery module, their parts may be crushed due to their heavy weight. Therefore, all persons involved in transportation must wear safety shoes with toe caps. Please observe the safety regulations for transportation at the end customer's site, especially during loading and unloading.
-  • During transportation and installation of unpacked battery storage cabinets, the risk of injury increases, especially on sharp metal panels. Therefore, all personnel involved in transportation and installation must wear protective gloves.

### 3.2 Permissible and Impermissible Storage Positions of a Packaged

The battery module can only be transported in an upright position.

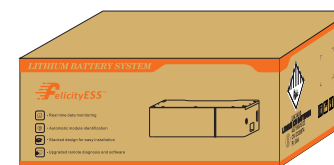

## 4. STORAGE

- Do not expose battery to open flame.
- Do not place the product under direct sunlight.
- Do not place the product near flammable materials. It may lead to fire or explosion in case of accident.
- Store in a cool and dry place with ample ventilation.
- Store the product on a flat surface.
- Store the product out of reach of children and animals.
- Do not damage the unit by dropping, deforming, impacting, cutting or penetrating with a sharp object. It may cause leakage of electrolyte or fire.
- Do not touch any liquid spilled from the product. There is a risk of electric shock or damage to skin.
- Always handle the battery wearing the insulated gloves.
- Do not step on the product or place any foreign objects on it. This can result in damage
- Do not charge or discharge damaged battery.

## 5. INTRODUCTION

The battery system main using solar power system for family house. It also have a with to controller the battery easily and protect our Household application timely.

### 5.1 Features

Features:

- LiFePO4:Higher safe performance and longer cycle life.
- Multiple Protection:Built-in smart BMS, Breaker and Fuse.
- Modular design for easy installation and increased capacity
- Flexible Installation:Wall-Mounted or Floor-Mounted.
- Wide Compatibility:Compatible with leading inverter brands.
- High Scalability:Capacity up to 39.84kWh.

### 5.2 Product Overview

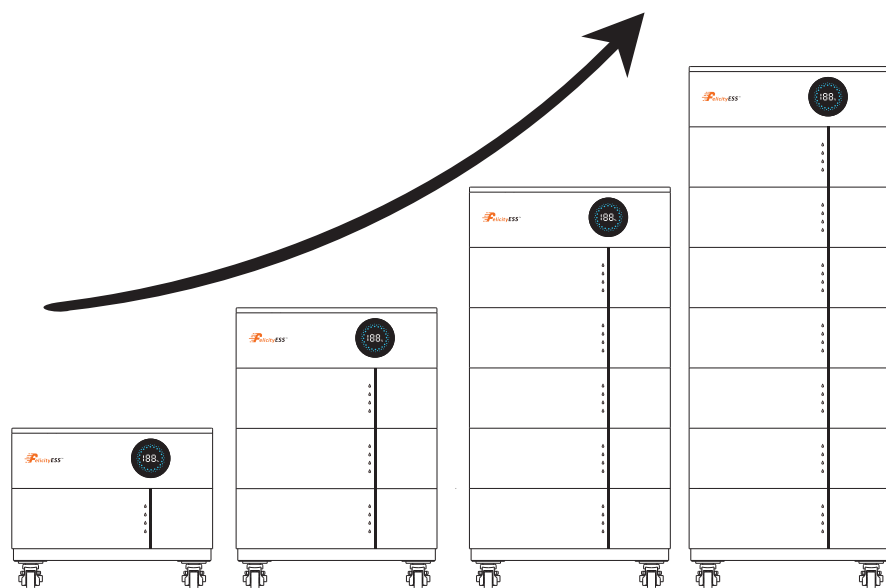

Up to 8 PCS battery packs can be connected in parallel

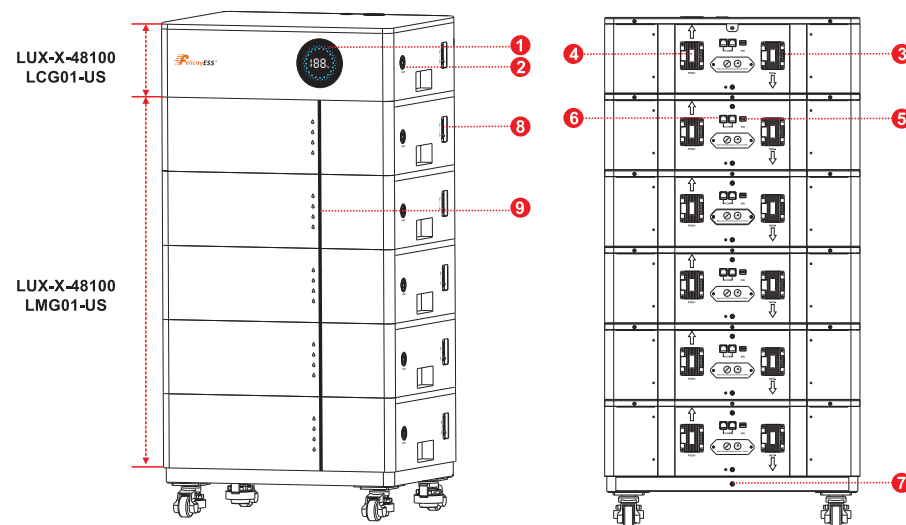

- |                       |                                |                       |
|-----------------------|--------------------------------|-----------------------|
| 1. LCD display        | 2. Power On/Charging indicator | 3. Battery Negative - |
| 4. Battery Positive + | 5. Switch                      | 6. Communication port |
| 7. Earth wire         | 8. Breaker                     | 9. LED                |

LUX-X-48100LCG01-US and LUX-X-48100LMG01-US both of battery packs contain batteries inside

- ✘ 9. Fuse (Non professionals are not allowed to open this cover)

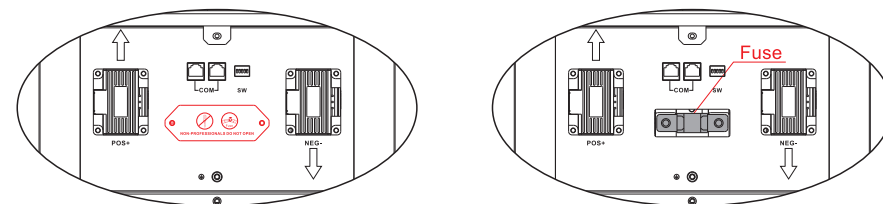

If the fuse is burnt out, please open the cover and replace it

### 5.3 Specifications

Model	LUX-X-48100LCG01-US	LUX-X-48100LMG01-US	LUX-X-48100LG01-USM2	LUX-X-48100LG01-USM3	LUX-X-48100LG01-USM4	LUX-X-48100LG01-USM5	LUX-X-48100LG01-USM6	LUX-X-48100LG01-USM7	LUX-X-48100LG01-USM8
Battery Type	LiFePO4								
Module Nominal Energy	4.98kWh								
Module Nominal Capacity	97.3Ah								
Module Nominal Voltage	51.2V								
Number of Battery Modules	1	1	2	3	4	5	6	7	8
System Nominal Energy	4.98kWh	4.98kWh	9.96kWh	14.94kWh	19.92kWh	24.9kWh	29.88kWh	34.86kWh	39.84kWh
System Nominal Voltage	51.2V								
System Operating Voltage	44.8-57.6V								
Recommend Charge/Discharge Current	50A	50A	100A	150A	200A	250A	300A	350A	400A
Max.continuous charge/Discharge current[1]	60A	60A	120A	180A	240A	300A	360A	400A	400A
Max. continuous charge/Discharge power	3072W	3072W	6144W	9216W	12288W	15360W	18432W	20480W	20480W
Peak Charge/Discharge Current(15s)	100A	100A	200A	300A	400A	500A	600A	700A	800A
Scalability	Max.8 pcs in Parallel(39.84kWh)								
Depth of Discharge(DOD)	≥ 95%								
Display type	Control Module:LCD/Battery Module:LED*4								
Protection Level	IP21								
Working Temperature Range	Charge: 0°C~+55°C								
	Discharge:-20°C~+55°C								
Storage Temperature Range	0°C~+35°C								
Humidity	5%~95%								
Altitude	≤ 2000m								
Communication	RS485 / CAN								
Cycle Life[2]	≥ 6000 Cycles								
Installation	Wall-Mounted / Floor-Mounted								
Protection	Built-in smart BMS, Breaker, Fuse								
Warranty Period[3]	10 Years								
Battery Designation[4]	IFpP/54/150/120/[(1P16S)NP]M-20+50/90								
Control Module LUX-X-48100LCG01-US	Product Weight Approximate	46kg							
	Package Weight Approximate(with base)	60kg							
	Product Dimension	600x450x180mm							
	Package Dimension (with base)	712x562x333mm							
Battery Module LUX-X-48100LMG01-US	Product Weight Approximate	46kg							
	Package Weight Approximate	50kg							
	Product Dimension	600x450x180mm							
	Package Dimension	712x562x298mm							
[1] Max.continuous charge/Discharge current is affected by temperature and SOC.									
[2] Test conditions: 0.2C Charging/Discharging @25°C, 80% DOD.									
[3] Conditions apply, refer to FelicityESS Warranty policy.									
[4] "N" means the number of battery packs connected parallel and should not exceed 8.(N≤8)									

### 5.4 Recommended Settings

Standard charging operation: At 25±2°C, the constant current of 50.0A is continuously charged to 57.6\*NV, and the constant voltage is charged at 57.6\*NV, until the current is less than 5.0A.

Lithium battery pack is not same as lead-acid battery, so for the devices which you connect with the battery pack for charging or discharging, such as inverters, MPPT charger controllers or UPS, please implement pre-settings as recommended settings as below before you launched them.



Setting	LUX-X-48100LG01-US
Max. Charging Voltage	57.6V
Floating charging Voltage	57.6V
Max. Charging Current	60A*N(Max=400A)
Cut-off voltage	48V



Notes:"N" means the number of battery packs connected parallel and should not exceed 8.(N≤8)



### 5.5 Model Description



Model	Description	Notes
LUX-X-48100LCG01-US	Control Module	Can be used separately
LUX-X-48100LMG01-US	Battery Module	It needs to be used with LUX-X-48100LCG01-US
LUX-X-48100LG01-USM2	LUX-X-48100LCG01*1PCS-US+LUX-X-48100LMG01-US*1PCS	Max.4 pcs in Parallel (19.92kWh) for Residential use ESS
LUX-X-48100LG01-USM3	LUX-X-48100LCG01*1PCS-US+LUX-X-48100LMG01-US*2PCS	
LUX-X-48100LG01-USM4	LUX-X-48100LCG01*1PCS-US+LUX-X-48100LMG01-US*3PCS	
LUX-X-48100LG01-USM5	LUX-X-48100LCG01*1PCS-US+LUX-X-48100LMG01-US*4PCS	
LUX-X-48100LG01-USM6	LUX-X-48100LCG01*1PCS-US+LUX-X-48100LMG01-US*5PCS	Max.8 pcs in Parallel (39.84kWh) for Non-residential use ESS
LUX-X-48100LG01-USM7	LUX-X-48100LCG01*1PCS-US+LUX-X-48100LMG01-US*6PCS	
LUX-X-48100LG01-USM8	LUX-X-48100LCG01*1PCS-US+LUX-X-48100LMG01-US*7PCS	



5.6 Lable



	
<b>Model</b>	LUX-X-48100L001-US
<b>Nominal Energy</b>	4.98kWh
<b>Nominal Voltage</b>	51.2V
<b>Nominal Capacity</b>	97.3Ah
<b>Maximum Continuous Charge/Discharge Current</b>	60A
<b>Maximum Short Circuit Current And Duration</b>	5000A 12ms
<b>Communication</b>	RS485 / CAN
<b>Cycle Life</b>	≥6,000@25°C, 80% DOD
<b>IP Rating of Enclosure</b>	IP21
<b>Working Temperature Range</b>	Charge: 0°C~+55°C Discharge: -20°C~+55°C
<b>Anti-electric shock level</b>	Protective class I
<p>Please read the user manual before using the battery pack. / Veuillez consulter le manuel d'utilisation avant d'utiliser le pack de batteries.</p> <p>Ensure that the battery is properly connected. / Assurez-vous que la batterie est correctement branchée.</p> <p>Do not reverse the positive and negative terminals of the battery. / Ne pas inverser les bornes positive et négative de la batterie.</p> <p>Do not expose the battery module to rain or submerge it in liquids. / Ne pas exposer le module de batterie à la pluie ni le immerger dans des liquides.</p>	
	
<p>Manufacturer: Guangdong Felicity New Energy Co., Ltd Address: (KongGangBaiYun)No. 2, Donghua Huayue Road, Renhe Town, Baiyun Area, Guangzhou, Guangdong, P. R. CHINA</p>	



	
<b>Model</b>	LUX-X-48100L001-US
<b>Nominal Energy</b>	4.98kWh
<b>Nominal Voltage</b>	51.2V
<b>Nominal Capacity</b>	97.3Ah
<b>Maximum Continuous Charge/Discharge Current</b>	60A
<b>Maximum Short Circuit Current And Duration</b>	5000A 12ms
<b>Communication</b>	RS485 / CAN
<b>Cycle Life</b>	≥6,000@25°C, 80% DOD
<b>IP Rating of Enclosure</b>	IP21
<b>Working Temperature Range</b>	Charge: 0°C~+55°C Discharge: -20°C~+55°C
<b>Anti-electric shock level</b>	Protective class I
<p>Please read the user manual before using the battery pack. / Veuillez consulter le manuel d'utilisation avant d'utiliser le pack de batteries.</p> <p>Ensure that the battery is properly connected. / Assurez-vous que la batterie est correctement branchée.</p> <p>Do not reverse the positive and negative terminals of the battery. / Ne pas inverser les bornes positive et négative de la batterie.</p> <p>Do not expose the battery module to rain or submerge it in liquids. / Ne pas exposer le module de batterie à la pluie ni le immerger dans des liquides.</p>	
	
<p>Manufacturer: Guangdong Felicity New Energy Co., Ltd Address: (KongGangBaiYun)No. 2, Donghua Huayue Road, Renhe Town, Baiyun Area, Guangzhou, Guangdong, P. R. CHINA</p>	



	
<b>Model</b>	LUX-X-48100L001-USM2
<b>Nominal Energy</b>	9.96kWh
<b>Nominal Voltage</b>	51.2V
<b>Nominal Capacity</b>	194.6Ah
<b>Maximum Continuous Charge/Discharge Current</b>	120A
<b>Maximum Short Circuit Current And Duration</b>	5000A 12ms
<b>Communication</b>	RS485 / CAN
<b>Cycle Life</b>	≥6,000@25°C, 80% DOD
<b>IP Rating of Enclosure</b>	IP21
<b>Working Temperature Range</b>	Charge: 0°C~+55°C Discharge: -20°C~+55°C
<b>Anti-electric shock level</b>	Protective class I
<p>Please read the user manual before using the battery pack. / Veuillez consulter le manuel d'utilisation avant d'utiliser le pack de batteries.</p> <p>Ensure that the battery is properly connected. / Assurez-vous que la batterie est correctement branchée.</p> <p>Do not reverse the positive and negative terminals of the battery. / Ne pas inverser les bornes positive et négative de la batterie.</p> <p>Do not expose the battery module to rain or submerge it in liquids. / Ne pas exposer le module de batterie à la pluie ni le immerger dans des liquides.</p>	
	
<p>Manufacturer: Guangdong Felicity New Energy Co., Ltd Address: (KongGangBaiYun)No. 2, Donghua Huayue Road, Renhe Town, Baiyun Area, Guangzhou, Guangdong, P. R. CHINA</p>	



	
<b>Model</b>	LUX-X-48100L001-USM3
<b>Nominal Energy</b>	14.94kWh
<b>Nominal Voltage</b>	51.2V
<b>Nominal Capacity</b>	291.9Ah
<b>Maximum Continuous Charge/Discharge Current</b>	180A
<b>Maximum Short Circuit Current And Duration</b>	5000A 12ms
<b>Communication</b>	RS485 / CAN
<b>Cycle Life</b>	≥6,000@25°C, 80% DOD
<b>IP Rating of Enclosure</b>	IP21
<b>Working Temperature Range</b>	Charge: 0°C~+55°C Discharge: -20°C~+55°C
<b>Anti-electric shock level</b>	Protective class I
<p>Please read the user manual before using the battery pack. / Veuillez consulter le manuel d'utilisation avant d'utiliser le pack de batteries.</p> <p>Ensure that the battery is properly connected. / Assurez-vous que la batterie est correctement branchée.</p> <p>Do not reverse the positive and negative terminals of the battery. / Ne pas inverser les bornes positive et négative de la batterie.</p> <p>Do not expose the battery module to rain or submerge it in liquids. / Ne pas exposer le module de batterie à la pluie ni le immerger dans des liquides.</p>	
	
<p>Manufacturer: Guangdong Felicity New Energy Co., Ltd Address: (KongGangBaiYun)No. 2, Donghua Huayue Road, Renhe Town, Baiyun Area, Guangzhou, Guangdong, P. R. CHINA</p>	

	
<b>Model</b>	LUX-X-48100L001-USM4
<b>Nominal Energy</b>	19.92kWh
<b>Nominal Voltage</b>	51.2V
<b>Nominal Capacity</b>	389.2Ah
<b>Maximum Continuous Charge/Discharge Current</b>	240A
<b>Maximum Short Circuit Current And Duration</b>	5000A 12ms
<b>Communication</b>	RS485 / CAN
<b>Cycle Life</b>	≥6,000@25°C, 80% DOD
<b>IP Rating of Enclosure</b>	IP21
<b>Working Temperature Range</b>	Charge: 0°C~+55°C Discharge: -20°C~+55°C
<b>Anti-electric shock level</b>	Protective class I
<p>Please read the user manual before using the battery pack. / Veuillez consulter le manuel d'utilisation avant d'utiliser le pack de batteries.</p> <p>Ensure that the battery is properly connected. / Assurez-vous que la batterie est correctement branchée.</p> <p>Do not reverse the positive and negative terminals of the battery. / Ne pas inverser les bornes positive et négative de la batterie.</p> <p>Do not expose the battery module to rain or submerge it in liquids. / Ne pas exposer le module de batterie à la pluie ni le immerger dans des liquides.</p>	
	
<p>Manufacturer: Guangdong Felicity New Energy Co., Ltd Address: (KongGangBaiYun)No. 2, Donghua Huayue Road, Renhe Town, Baiyun Area, Guangzhou, Guangdong, P. R. CHINA</p>	

	
<b>Model</b>	LUX-X-48100L001-USM5
<b>Nominal Energy</b>	24.9kWh
<b>Nominal Voltage</b>	51.2V
<b>Nominal Capacity</b>	486.5Ah
<b>Maximum Continuous Charge/Discharge Current</b>	300A
<b>Maximum Short Circuit Current And Duration</b>	5000A 12ms
<b>Communication</b>	RS485 / CAN
<b>Cycle Life</b>	≥6,000@25°C, 80% DOD
<b>IP Rating of Enclosure</b>	IP21
<b>Working Temperature Range</b>	Charge: 0°C~+55°C Discharge: -20°C~+55°C
<b>Anti-electric shock level</b>	Protective class I
<p>Please read the user manual before using the battery pack. / Veuillez consulter le manuel d'utilisation avant d'utiliser le pack de batteries.</p> <p>Ensure that the battery is properly connected. / Assurez-vous que la batterie est correctement branchée.</p> <p>Do not reverse the positive and negative terminals of the battery. / Ne pas inverser les bornes positive et négative de la batterie.</p> <p>Do not expose the battery module to rain or submerge it in liquids. / Ne pas exposer le module de batterie à la pluie ni le immerger dans des liquides.</p>	
	
<p>Manufacturer: Guangdong Felicity New Energy Co., Ltd Address: (KongGangBaiYun)No. 2, Donghua Huayue Road, Renhe Town, Baiyun Area, Guangzhou, Guangdong, P. R. CHINA</p>	

	
<b>Model</b>	LUX-X-48100L001-USM6
<b>Nominal Energy</b>	29.88kWh
<b>Nominal Voltage</b>	51.2V
<b>Nominal Capacity</b>	583.8Ah
<b>Maximum Continuous Charge/Discharge Current</b>	360A
<b>Maximum Short Circuit Current And Duration</b>	5000A 12ms
<b>Communication</b>	RS485 / CAN
<b>Cycle Life</b>	≥6,000@25°C, 80% DOD
<b>IP Rating of Enclosure</b>	IP21
<b>Working Temperature Range</b>	Charge: 0°C~+55°C Discharge: -20°C~+55°C
<b>Anti-electric shock level</b>	Protective class I
<p>Please read the user manual before using the battery pack. / Veuillez consulter le manuel d'utilisation avant d'utiliser le pack de batteries.</p> <p>Ensure that the battery is properly connected. / Assurez-vous que la batterie est correctement branchée.</p> <p>Do not reverse the positive and negative terminals of the battery. / Ne pas inverser les bornes positive et négative de la batterie.</p> <p>Do not expose the battery module to rain or submerge it in liquids. / Ne pas exposer le module de batterie à la pluie ni le immerger dans des liquides.</p>	
	
<p>Manufacturer: Guangdong Felicity New Energy Co., Ltd Address: (KongGangBaiYun)No. 2, Donghua Huayue Road, Renhe Town, Baiyun Area, Guangzhou, Guangdong, P. R. CHINA</p>	

	
<b>Model</b>	LUX-X-48100L001-USM7
<b>Nominal Energy</b>	34.86kWh
<b>Nominal Voltage</b>	51.2V
<b>Nominal Capacity</b>	681.1Ah
<b>Maximum Continuous Charge/Discharge Current</b>	400A
<b>Maximum Short Circuit Current And Duration</b>	5000A 12ms
<b>Communication</b>	RS485 / CAN
<b>Cycle Life</b>	≥6,000@25°C, 80% DOD
<b>IP Rating of Enclosure</b>	IP21
<b>Working Temperature Range</b>	Charge: 0°C~+55°C Discharge: -20°C~+55°C
<b>Anti-electric shock level</b>	Protective class I
<p>Please read the user manual before using the battery pack. / Veuillez consulter le manuel d'utilisation avant d'utiliser le pack de batteries.</p> <p>Ensure that the battery is properly connected. / Assurez-vous que la batterie est correctement branchée.</p> <p>Do not reverse the positive and negative terminals of the battery. / Ne pas inverser les bornes positive et négative de la batterie.</p> <p>Do not expose the battery module to rain or submerge it in liquids. / Ne pas exposer le module de batterie à la pluie ni le immerger dans des liquides.</p>	
	
<p>Manufacturer: Guangdong Felicity New Energy Co., Ltd Address: (KongGangBaiYun)No. 2, Donghua Huayue Road, Renhe Town, Baiyun Area, Guangzhou, Guangdong, P. R. CHINA</p>	

	
<b>Model</b>	LUX-X-48100L001-USM8
<b>Nominal Energy</b>	39.84kWh
<b>Nominal Voltage</b>	51.2V
<b>Nominal Capacity</b>	778.4Ah
<b>Maximum Continuous Charge/Discharge Current</b>	400A
<b>Maximum Short Circuit Current And Duration</b>	5000A 12ms
<b>Communication</b>	RS485 / CAN
<b>Cycle Life</b>	≥6,000@25°C, 80% DOD
<b>IP Rating of Enclosure</b>	IP21
<b>Working Temperature Range</b>	Charge: 0°C~+55°C Discharge: -20°C~+55°C
<b>Anti-electric shock level</b>	Protective class I
<p>Please read the user manual before using the battery pack. / Veuillez consulter le manuel d'utilisation avant d'utiliser le pack de batteries.</p> <p>Ensure that the battery is properly connected. / Assurez-vous que la batterie est correctement branchée.</p> <p>Do not reverse the positive and negative terminals of the battery. / Ne pas inverser les bornes positive et négative de la batterie.</p> <p>Do not expose the battery module to rain or submerge it in liquids. / Ne pas exposer le module de batterie à la pluie ni le immerger dans des liquides.</p>	
	
<p>Manufacturer: Guangdong Felicity New Energy Co., Ltd Address: (KongGangBaiYun)No. 2, Donghua Huayue Road, Renhe Town, Baiyun Area, Guangzhou, Guangdong, P. R. CHINA</p>	

5.7 Scalability

Max.4 pcs in Parallel(19.92kWh) for Residential use ESS.  
Max.8 pcs in Parallel(39.84kWh) for Non-residential use ESS.

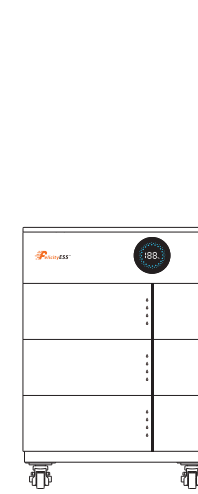

Residential use ESS

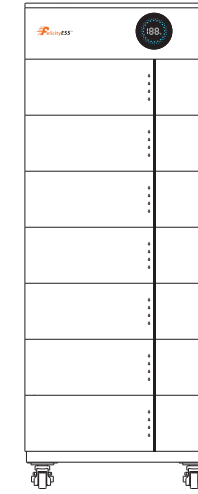

Non-residential use ESS

6. INSTALLATION

6.1 Tools



Screw Driver

Crimping Modular

Safety Shoes

Multimeter



Safety Gloves

Safety Goggles











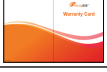

Plier













Ribbon

Electric drill

### 6.2 Unpacking and Inspection

Before installation, please inspect the unit. Be sure that nothing inside the package is damaged. You should have received the following items inside of package.

LUX-X-48100LCG01-US			
NO.	Description	Quantity	Picture
1	The base is used for product placement and plays a supporting role	1	
2	User Manual	1	
3	Quick Installation Guide	1	
4	Warranty Card	1	
5	Power Cable 1: 0.9 meters, 35mm <sup>2</sup> , allows for charging and discharging up to 150A, used for connecting to external PCS+ (red)	2	
	Power Cable 2: 2.3 meters, 35mm <sup>2</sup> , allows for charging and discharging up to 150A, used for connecting to external PCS- (black)		
6	Ground Wire: Used for grounding connections between the master and slave controllers	1	
7	Communication Cable 1: Gray, used for RS485 communication with Felicity inverters (Model:T-REX-5KLP1G01,T-REX-10KLP3G01)	1	
8	Communication cable 2:Blue 1.used for CAN communication with inverters from other brands 2.used for CAN communication with Felicity inverters (Model:T-REX-8KLP2G01-EU, T-REX-8KLP2G01-US, T-REX-15KLP3G02, T-REX-25KHP3G02)	1	
9	Communication Cable 3: Yellow, without an RJ45 connector. Universal communication cable with one end as RJ45 and the other end leading to eight cores.	1	
10	Hole Marking Cardboard: Used to mark drilling positions during product installation. For detailed installation instructions, please refer to the installation steps below	1	
11	Hex Wrench: Used as a tool for stacking and securing products. For detailed installation instructions, please refer to the installation steps below	1	
12	OT Terminal: Screw hole diameter 10.5mm, wire crimp hole diameter 17mm, used with 150mm <sup>2</sup> power cables	4	
13	Plastic Expansion Screw: Used together for product fixation	4	

14	Signal Terminal: Used for creating custom communication cables	2	
15	Fixed trestle: Used for fixing products	4	
16	Screws M5X12*8 PCS Screws M6X16*16 PCS Screws M5X25*2 PCS	/	
17	Casters: Used for product support and short-distance transportation	4	
LUX-X-48100LMG01-US			
NO.	Description	Quantity	Picture
1	Usermanual	1	
2	Quick Installation Guide	1	
3	Warranty card	1	
4	Ground Wire: used for grounding connections between stackable battery packs.	1	
5	Plastic expansion screws are used to secure products and walls	2	
6	Screws M5X12*4PCS Screws M5X25*2PCS	/	
7	Parallel Soft Copper Busbar: allows for charging and discharging up to 450A, used for parallel connections between stackable battery packs.	2	
8	Communication Cable 4:Black,used for parallel communication between battery packs	1	
10	Fixed trestle:Used for fixing products	2	

### 6.3 Mounting the Unit

Consider the following points before selecting where to install:

- Do not mount the battery on flammable construction materials.
- The ambient temperature should be between 0°C and 45°C to ensure optimal operation.
- The recommended installation position is to be adhered to the wall vertically.
- Make sure that other objects and surfaces are consistent as shown in the image below to ensure adequate heat dissipation and enough space to remove wires.

Please follow below steps to implement battery connection:

1. Assemble battery ring terminal based on recommended battery cable and terminal size.
2. Connect all battery packs as units requires. It's suggested to connect at least 2 sets for inverter larger than the energy of a battery pack in parallel connection.

### 6.4 Product size information

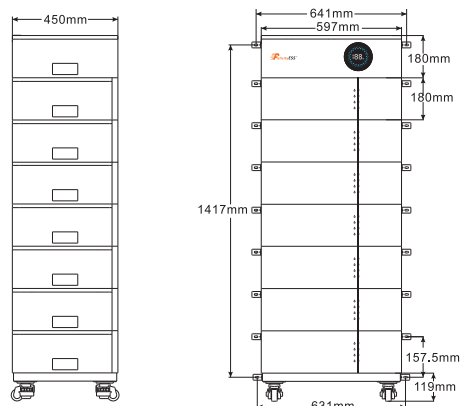

### 6.5 Floor Installation with Base Installation Location Requirements

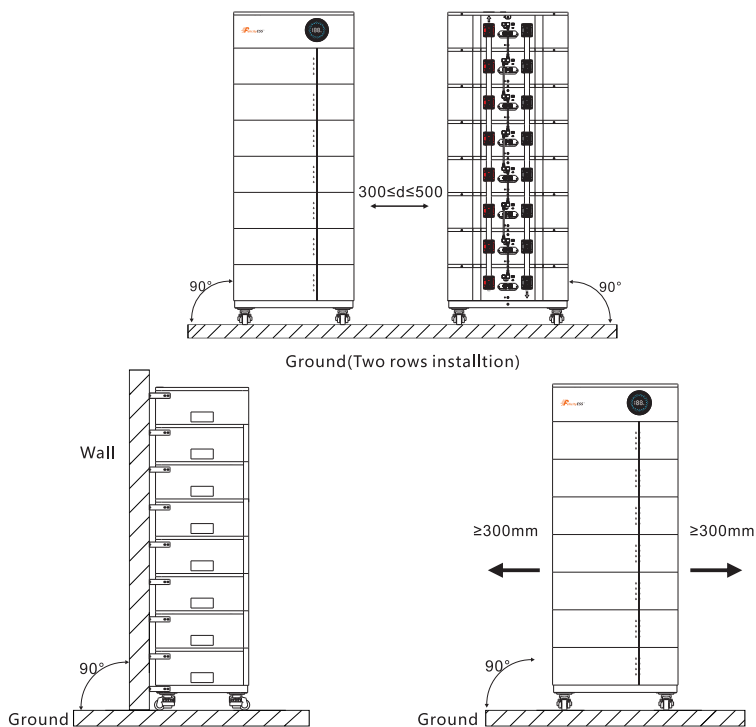

### 6.6 Installation Environment

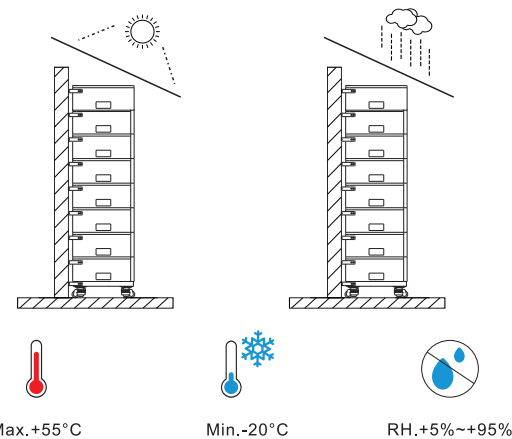

## 7. INSTALLATION PROCEDURE

### 7.1 Setup Script

**Step 1:** Open the packaging Carton box and remove the accessories (LUX-X-48100LCG01-US battery pack, base, wheel\*4PCS) ;

**Step 2:** Open the packaging Carton box and remove the accessories (LUX-X-48100LMG01-US battery pack) .

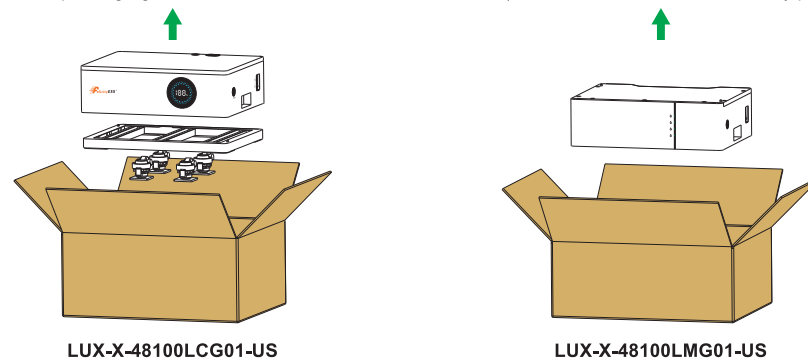

**Step 3:** Fix the 4 casters on the base using M6X16 screws

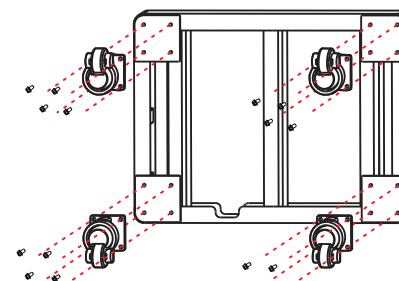

**Step 4:** Place the base, which should be 35MM away from the wall.

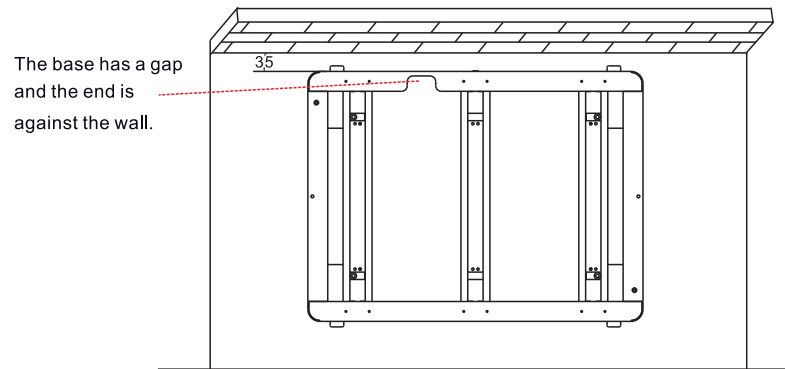

**Step 5:** Use wall mounted positioning cardboard, and mark the holes layer by layer.

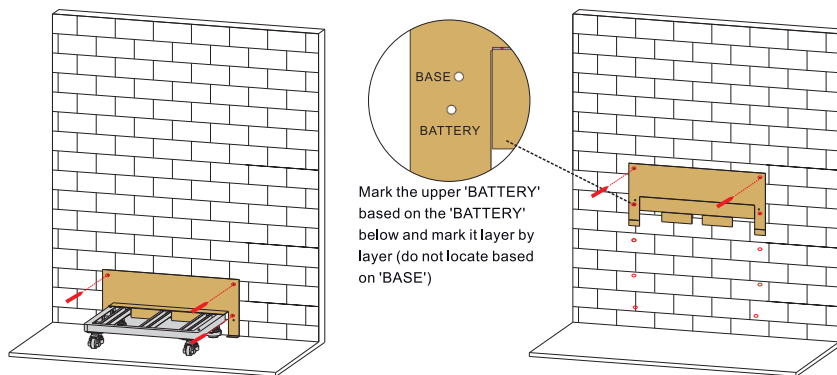

**Step 6:** Drill holes according to the position marked on the installation hole position cardboard (note: the hole diameter is 10mm, and the drilling depth is 60mm)

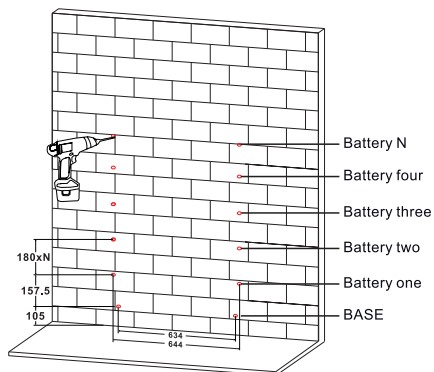

**Step 7:** Stack and place the products, with a base on the bottom layer, LED lights on the middle layer, and an LCD display screen on the top layer

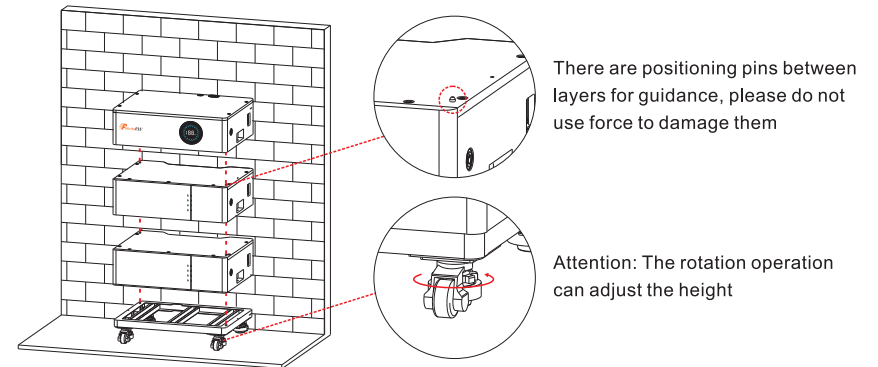

**Step 8:** Use sheet metal lock wall components to fix the product on the wall

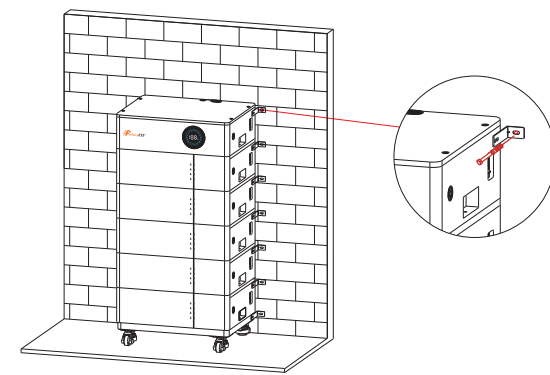

The battery packaging layer is fixed between the layers using hexagonal screws (at the handle)

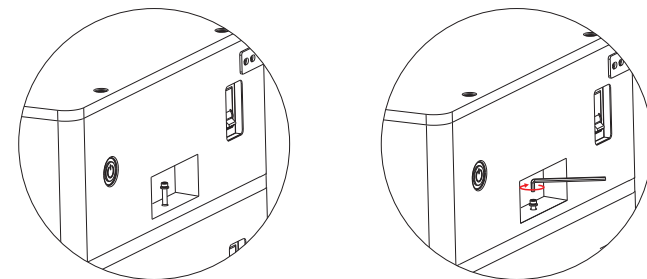

### 7.2 Connection for Parallel Mode

Please open the lid latch upwards, rotate the lid and tear off the lid cover. Use screws to connect the copper bar, with the positive pole connected from bottom to top and the negative pole connected from top to bottom.

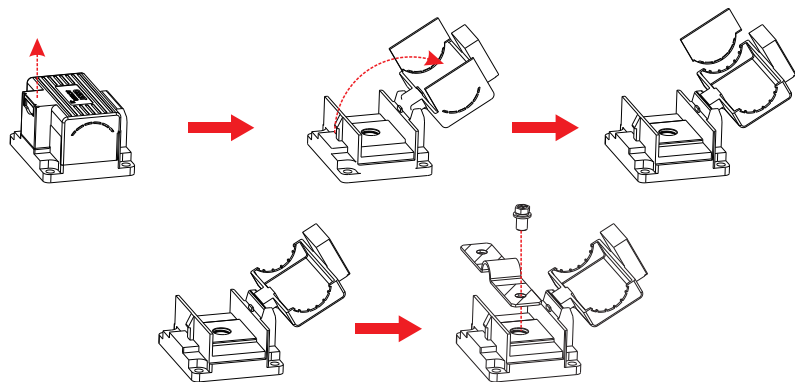

The LUX-X-48100LG01-US series battery support to be connected in parallel for expansion. If you need one more battery bank work in parallel mode, connect the battery as shown in PIC 1.

Note: The upper and lower battery packs are connected in parallel.

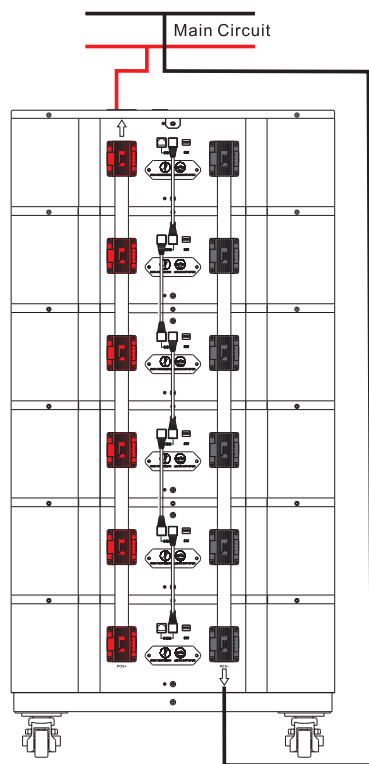

The diagram of six battery strings in parallel is shown in the figure above. In order to maintain the current balance of the battery pack, please ensure that the negative electrode of the battery comes out from the bottom.

Adjust each battery pack dialer from left to right according to the diagram below (from top to bottom)

No. of BAT	ON DP							
	1	2	3	4	5	6	7	8
1PCS	1,5 ON							
2PCS	1,5 ON	2,5 ON						
3PCS	1,5 ON	2 ON	1,2,5ON					
4PCS	1,5 ON	2 ON	1,2 ON	3,5 ON				
5PCS	1,5 ON	2 ON	1,2 ON	3 ON	1,3,5 ON			
6PCS	1,5 ON	2 ON	1,2 ON	3 ON	1,3 ON	2,3,5 ON		
7PCS	1,5 ON	2 ON	1,2 ON	3 ON	1,3 ON	2,3 ON	1,2,3,5 ON	
8PCS	1,5 ON	2 ON	1,2 ON	3 ON	1,3 ON	2,3 ON	1,2,3 ON	4,5 ON

**Note:** After completing the above steps, arbitrarily select the positive and negative poles of one of the battery packs to output. After confirming the correct connection of the inverter, controller and battery, you can turn on any of the switches and use the battery group happily.

For pure off-grid systems, the power line needs to be connected to the battery's MPPT charging controller and the battery pack is only charged by the solar panel, the connection diagram is as follows:

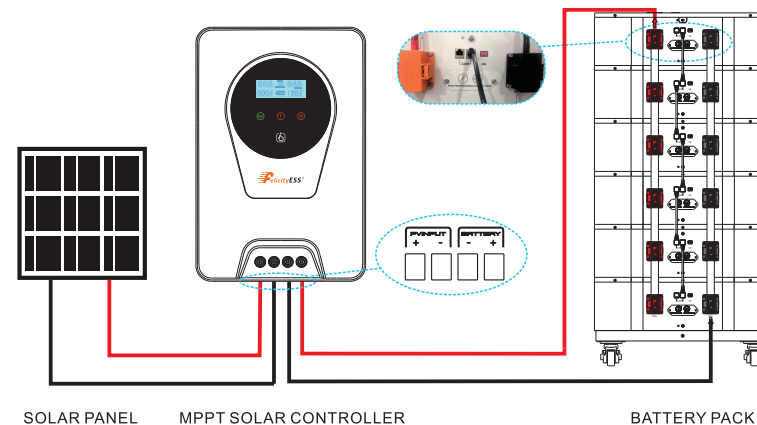

## 8. OPERATION

Once the batteries are connected well, close the breaker to the ON block, press On/Off button to enable the output of the battery pack.

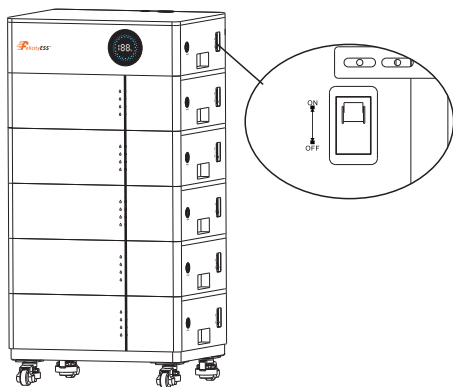

### 8.1 Switch On / Off

- 1.Switch on: press On/Off button to switch on the battery, then the battery will do self-inspection before enable output. The LCD will show the SOC.
- 2.Switch off: press and hold On/Off button for 1to3 seconds, the battery will shut down directly. Description for Communication port

Picture	PIN	Description
	1	Trigger-GND
	2	Trigger-VCC
	3	CANL-PCS
	4	CANH-PCS
	5	RS485-B
	6	RS485-A
	7	CANL
	8	CANH

DIP SWITCH		
	1-4	Communication Address
	5	Termination Resister

### 8.2 Description for LED

The LED shows the SOC of module N.

100%	75%	50%	25%	Flashing SOC < 10%

Note: The battery need to be fully charged for at least once in one month to ensure the accurate SOC calculation.

### 8.3 ON / OFF or SOC Led (Mode or SOC)





BATTERY MODE	ON/OFF		SOC				REMARK
	GREEN LED	RED LED	LED1	LED2	LED3	LED4	
POWER OFF	OFF	OFF	OFF	OFF	OFF	OFF	
POWER ON	OFF	ON	ON	ON	ON	ON	
STANDBY	OFF	OFF	SOC				SOC < 10%(DEFAULT): LED1 FLASH
NORMAL	ON	OFF	RUNNING /SOC				SOC < 10%(DEFAULT): LED1 FLASH
DISCHARGE	ON	OFF	SOC				SOC < 10%(DEFAULT): LED1 FLASH
CHARGE	FLASH	OFF	RUNNING				
LOW POWER	FLASH	OFF	OFF				
FAULT	OFF	ON	ON	OFF	OFF	OFF	BATTERY VOLTAGE HIGH
			OFF	ON	OFF	OFF	BATTERY VOLTAGE LOW
			ON	ON	OFF	OFF	CELL VOLTAGE HIGH
			OFF	OFF	ON	OFF	CELL VOLTAGE LOW
			ON	OFF	ON	OFF	CHARGING CURRENT HIGH
			OFF	ON	ON	OFF	DISCHARGING CURRENT HIGH
			ON	ON	ON	OFF	BMS TEMPERATURE HIGH
			OFF	OFF	OFF	ON	BMS TEMPERATURE LOW
			ON	OFF	OFF	ON	CELL TEMPERATURE HIGH
			OFF	ON	OFF	ON	CELL TEMPERATURE LOW
ON	ON	OFF	ON	CURRENT SENSOR ABNOMAL			

## 9. LCD Display Icons

Icon	Function Description
Display Information	
	Indicates the voltage, current, temperature, SOC of the module. (Short press the button to display the information of each parallel module.)
	Indicates SOC
	<b>Indicates battery level, each LED represents 5%.</b> (When charging, this icon flashes; when discharging, the icon displays <b>constant</b> )
	Indicates settings.
	Indicates a fault.
	Indicates communication signs.

### 9.1 BMS Information Page

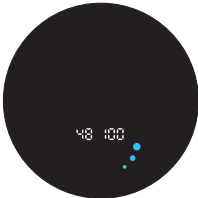
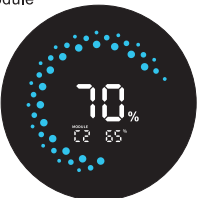
The basic information will be displayed in turn after power on.

<p><b>BMS power on information</b> BMS information is all on.</p> 	<p><b>BMS version</b> Eg: "516" is the software version, "500" is the IAP version and temporary version.</p> 
<p><b>BMS type</b> Eg: Rated voltage is "48V", model is "100AH".</p> 	<p><b>BMS data</b> This interface indicates that it is in SOC calibration.</p> 
<p><b>BMS data</b> Eg: "70%" refer to battery SOC, "C" indicates that the battery is charging, and if it is discharging, "d" is displayed. "2" indicates that the data currently displayed is for module 2, "65%" represents the SOC of module 2. Short press the button to display the information of each parallel module</p> 	<p><b>BMS data</b> Eg: "70%" refer to battery SOC, "52.0V" refer to battery voltage, "35A" refer to battery current. Short press the button to display the information of each parallel module</p> 
<p><b>BMS fault code / flag</b> Eg: "52.0V" / "C09" / "70%" are battery voltage, fault code and SOC respectively, and Fault icon constant</p> 	

### 9.2 Fault Code Table

Fault Code	Fault information	Trouble Shooting
C01	Battery overvoltage	Restart the unit, if the error happens again, please return to repair center.
C02	Battery undervoltage	Restart the unit, if the error happens again, please return to repair center.
C03	Cell overvoltage	Restart the unit, if the error happens again, please return to repair center.
C04	Cell undervoltage	Restart the unit, if the error happens again, please return to repair center.
C05	Charge overcurrent	Restart the unit, if the error happens again, please return to repair center.
C06	Discharge overcurrent	Restart the unit, if the error happens again, please return to repair center.
C07	MOS overtemperature	1 .The inner temperature is over the limitation. 2. Check whether the ambient temperature is too high.
C07	MOS overtemperature	1 .The inner temperature is over the limitation. 2. Check whether the ambient temperature is too high.
C08	MOS undertemperature	1. The internal temperature is lower than the limit range. 2. Check whether the ambient temperature is too low.
C09	Cell overtemperature	Restart the unit, if the error happens again, please return to repair center.
C10	Cell undertemperature	Restart the unit, if the error happens again, please return to repair center.
C11	Abnormal current sampling	Restart the unit, if the error happens again, please return to repair center.
C12	Abnormal output impedance	Restart the unit, if the error happens again, please return to repair center.
C13	Parallel failed	1. Please check if single unit is installed to parallel system. 2. If this error happens during parallel installation, please check wires connection. If they are connected correctly, please finish parallel installation first, and then Restart the unit. 3. If the problem remains, please contact your installer.
C14	Output loss	1. Please check whether the circuit breaker is closed; 2. Please check whether the fuse is normal; 3. Restart the unit, If the error happens again, please return to repair center.

### 9.3 DIP switch SW1-SW4 Description

DIP switch SW1-SW4 Description ①					DIP switch SW5 Description②			
Sw1	SW2	SW3	SW4	Remarks	SW5	Remarks		
0	0	0	0	means ID=0,communication address is0x00/0x10③	1	means connect 120Ω resistor		
1	0	0	0	means ID=1,communication address is0x01④				
0	1	0	0	means ID=2,communication address is0x02	0	means disconnect 120Ω resistor		
1	1	0	0	means ID=3,communication address is0x03				
0	0	1	0	means ID=4,communication address is0x04				
1	0	1	0	means ID=5,communication address is0x05				
0	1	1	0	means ID=6,communication address is0x06				
1	1	1	0	means ID=7,communication address is0x07				
0	0	0	1	means ID=8,communication address is0x08				
1	0	0	1	means ID=9,communication address is0x09				
0	1	0	1	means ID=10,communication address is0x0A				
1	1	0	1	means ID=11,communication address is0x0B				
0	0	1	1	means ID=12,communication address is0x0C				
1	0	1	1	means ID=13,communication address is0x0D				
0	1	1	1	means ID=14,communication address is0x0E				
1	1	1	1	means ID=15,communication address is0x0F				
Remark①: 1 in SW1-SW5 indicates ON status, and 0 indicates OFF status.								
Remark②: When multiple battery packs communicate, the last battery pack SW5 needs to be in the ON status, otherwise the communication may have interference.								
Remark③: When the battery pack ID is set to 0, it means stand-alone operation, and it is not necessary to detect whether the parallel condition is satisfied ⑤								
Remark④: When the battery pack ID is set to 1-15, it means that the parallel operation is required, and it is necessary to detect whether the parallel condition is satisfied ⑤								
Remark⑤: The parallel condition is that the difference between the battery voltage of the local battery and all the battery pack voltages is <3V, otherwise wait until the condition is satisfied								

## 10. EMERGENCY SITUATIONS

FelicityESS cannot guarantee battery absolute safety.

### 10.1 Fire

In case of fires, make sure that the following equipment is available near the system.

- SCBA (self-contained breathing apparatus) and protective gear in compliance with the Directive on Personal Protective Equipment 89/686/EEC.
- NOVEC 1230, FM-200, or dioxide extinguisher

Batteries may explode when heated above 150°C. KEEP FAR AWAY from the battery if it catches fire.

### 10.2 Leaking Batteries

If the battery pack leaks electrolyte, avoid contact with the leaking liquid or gas. If one is exposed the leaked substance, immediately perform the actions described below.

- Inhalation: Evacuate the contaminated area, and seek medical attention.
- Contact with eyes: Rinse eyes with running water for 5 minutes, and seek medical attention.
- Contact with skin: Wash the affected area thoroughly with soap and water, and seek medical attention.
- Ingestion: Induce vomiting, and seek medical attention.

### 10.3 Wet Batteries

If the battery pack is wet or submerged in water, do not let people access it, and contact your supplier for help.

### 10.4 Damaged Batteries

Damaged batteries are not fit for use and are dangerous and must be handled with the utmost care. It may leak electrolyte or produce flammable gas. If the battery pack seems to be damaged, pack it in its original container, and then return it to your supplier.

### 10.5 Warranty

Products that are operated strictly in accordance with the user manual are covered by the warranty. Any violation of this manual may void the warranty.

Limitation of Liability

Any product damage or property loss caused by the following conditions, FelicityESS does not assume any direct or indirect liability.

- Product modified, design changed or parts replaced.
- Changed, or attempted repairs and erasing of series number or seals;
- System design and installation are not in compliance with standards and regulations;
- The product has been improperly stored in end user's premises;
- Transport damage (including painting scratch caused by movement inside packaging during shipping). A claim should be made directly to shipping or insurance company.